



Tucson Electric Power

# 138 Kilovolt Transmission Line Underground Cost Analysis

**Report SL-015392**

**Revision 4**

**Report**

6751 N. Sunset Blvd. Suite E400  
Glendale, AZ 85305  
312-269-2000  
[www.sargentlundy.com](http://www.sargentlundy.com)



---

## LEGAL NOTICE

---

This deliverable was prepared by Sargent & Lundy (S&L) for the use of Tucson Electric Power (Client) in accordance with the contract agreement between S&L and Client. This deliverable was prepared using the degree of skill and care ordinarily exercised by engineers practicing under similar circumstances. Client acknowledges: (1) S&L prepared this deliverable subject to the particular scope limitations, budgetary and time constraints, and business objectives of Client; (2) information and data provided by others, including Client, may not have been independently verified by S&L; and (3) the information and data contained in this deliverable are time-sensitive and changes in the data, applicable codes, standards, and acceptable engineering practices may invalidate the findings of this deliverable. Any use or reliance upon this deliverable by third parties shall be at their sole risk.

## ISSUE SUMMARY AND APPROVAL PAGE

This is to certify that this document has been prepared, reviewed and approved in accordance with Sargent & Lundy's Standard Operating Procedure SOP-0405, which is based on ANSI/ISO/ASSQC Q9001 Quality Management Systems.

### Contributors

Prepared by:

Name	Title	Signature	Date
Jason Jocham	Project Manager		2/11/20
Jason Jocham	Project Manager		9/28/20
Justin Stiener	Associate		11/30/20
Justin Stiener	Associate		2/2/21

Reviewed by:

Name	Title	Signature	Date
Calvin Yanaga	Engineering Manager		2/11/20
Calvin Yanaga	Engineering Manager		9/28/20
Ethan Evans	Senior Associate		11/30/20
Ethan Evans	Senior Associate		2/2/21

Approved by: Jason Jocham

\_\_\_\_\_  
 Jason Jocham  
 Project Manager

\_\_\_\_\_  
 2/2/21



## TABLE OF CONTENTS

<b>EXECUTIVE SUMMARY</b> .....	<b>1</b>
SCOPE OF WORK.....	1
OVERVIEW OF PROJECT DESIGN.....	1
SUMMARY .....	1
<b>1. STUDY DESCRIPTION</b> .....	<b>2</b>
1.1. OVERVIEW .....	2
<b>2. UNDERGROUND CABLE SYSTEMS</b> .....	<b>2</b>
2.1. SYSTEM AMPACITY RATINGS .....	2
2.1.1. SOIL THERMAL RESISTIVITY .....	2
2.1.2. CABLE SIZE.....	2
2.1.3. CABLE DEPTH.....	2
2.1.4. CABLE SEPARATION .....	3
2.2. INSTALLATION METHODS.....	3
2.2.1. OPEN TRENCH .....	3
2.2.2. TRENCHLESS INSTALLATION.....	6
2.2.3. VAULTS.....	7
2.2.4. CABLE INSTALLATION AND TESTING.....	9
2.3. MAINTENANCE .....	10
2.3.1. CABLE FAILURE AND REPAIR .....	10
<b>3. PRELIMINARY DESIGN</b> .....	<b>11</b>
3.1. DESIGN INPUTS .....	12
3.2. ELECTRICAL DESIGN .....	12
3.2.1. AMPACITY .....	12
3.2.2. CHARGING CURRENT .....	14
3.2.3. MAGNETIC FIELD .....	14
3.3. OPEN CUT TRENCH PARAMETERS.....	16
3.4. TRENCHLESS DESIGN PARAMETERS .....	17
<b>4. COST ESTIMATE</b> .....	<b>19</b>
4.1. COST ESTIMATE ASSUMPTIONS .....	19
4.2. COST ESTIMATE .....	20
<b>5. CONCLUSIONS</b> .....	<b>20</b>
<b>6. APPENDIX A – SECTION COST SUMMARIES</b> .....	<b>21</b>
<b>7. APPENDIX B – ROUTE MAP</b> .....	<b>22</b>

---

## TABLE OF FIGURES

---

FIGURE 2-1 — TYPICAL URBAN OPEN TRENCH CONSTRUCTION .....	4
FIGURE 2-2 — OPEN TRENCH SPACERS.....	5
FIGURE 2-3— OPEN TRENCH CONCRETE.....	5
FIGURE 2-4 — JACK AND BORE – SEND PIT .....	6
FIGURE 2-5 — JACK AND BORE – EQUIPMENT.....	7
FIGURE 2-6 – MAN VAULT PLACEMENT .....	8
FIGURE 2-7 – MAN VAULT BACKFILL .....	8
FIGURE 2-8 – XLPE CABLE REEL .....	9
FIGURE 2-9 – XLPE CABLE INSTALLATION .....	10
FIGURE 3-1 – 1584A PER PHASE MAGNETIC FIELD RESULTS.....	15
FIGURE 3-2 – 2264A PER PHASE MAGNETIC FIELD RESULTS.....	16
FIGURE 3-3 — PRELIMINARY DUCT BANK LAYOUT .....	17
FIGURE 3-4 — PRELIMINARY BORE LAYOUT .....	18

---

## LIST OF TABLES

---

TABLE 1 – SECTIONS.....	11
TABLE 2 – PRELIMINARY CABLE DATA .....	12
TABLE 3 – MAXIMUM STEADY STATE AMPACITY AT RATED TEMPERATURE (90°C) .....	13
TABLE 4 – CHARGING CURRENT – CALCULATED RESULT .....	14
TABLE 5 – 1584A MAGNETIC FIELD RESULTS .....	15
TABLE 6 – 2264A MAGNETIC FIELD RESULTS .....	16
TABLE 7 – COST ESTIMATE SUMMARY .....	20

---

## ACRONYMS AND ABBREVIATIONS

---

Acronym/Abbreviation	Definition/Clarification
AC	Alternating Current
DC	Direct Current
DTS	Distributed Temperature Sensing
ft	Foot
GCC	Ground Continuity Conductor
HDD	Horizontal Directional Drill
HDPE	High Density Polyethylene
HVED	High Voltage Extruded Dielectric
HV	High Voltage
Kcmil	1000 circular mils
kV	Kilovolt
mil	Thousandth of an inch
PVC	Polyvinyl Chloride
ROW	Right of Way
XLPE	Cross-linked polyethylene

## EXECUTIVE SUMMARY

### SCOPE OF WORK

Tucson Electric Power (TEP) is proposing to install a new overhead single circuit 138 kilovolt (kV) alternating current (AC) transmission line from the Kino Substation (currently under construction) extending approximately 7 miles northwest to the existing DeMoss-Petrie Substation with a new proposed intermediate substation north of the University of Arizona. The line is being developed to help satisfy growing energy needs and strengthen reliability for TEP customers within the project area. During preliminary community meetings, TEP has received multiple questions regarding the cost of undergrounding the proposed transmission line. In response to those questions, TEP has enlisted Sargent and Lundy (S&L) to evaluate and prepare estimated costs to place the proposed 138kV transmission line underground. The material and construction costs in this report represents multiple sections equaling a total of 5.5 mile of underground 138-kV transmission circuit in urban, central Tucson. In Addition, this report provides an overview of a 138kV cross-linked polyethylene cable (XLPE) underground transmission line along with information on operation, maintenance and potential repairs.

### OVERVIEW OF PROJECT DESIGN

For the purposes of this study, preliminary calculations show that a two cable per phase installation is required to meet ampacity. See preliminary modeling performed by S&L as described in section 3.2.1. The duct banks would be installed via open-cut trench and then backfilled with thermally corrective fill to improve cable operating performance. The investigation of the proposed route evaluates the crossing of a Union Pacific railroad as well as major arterials within the City of Tucson. Due to the railroad sensitivity and the high traffic volume of the parkway a jack and bore has been assumed in this area. The cost estimate utilized anticipated construction methods and expected geological and environmental conditions based upon preliminary known data from TEP database. Detailed assumptions are provided in Section 4 of this report.

### SUMMARY

Underground transmission line installation, although possible, is significantly more expensive compared to overhead alternatives. Per estimates provided in this document, the cost of undergrounding could be up to approximately 14 times greater than a comparable overhead installation dependent on the section evaluated. The overall cost of the transmission line would vary depending on the length of the undergrounding, the construction methods used, and the obstructions encountered. These costs do not include permitting, right of way acquisition, or environmental cost at this early stage. This report is prepared to evaluate the feasibility and preliminary cost of undergrounding the proposed transmission line. The estimate may increase based upon permitting and right of way acquisition. In addition to the initial installation cost, there are operational, power transfer capabilities, maintenance, and reliability concerns when compared to overhead construction.

- Operational and Reliability Concerns – With the installation of the transmission line cables in a concrete-encased duct bank, repairs to damaged installations are required less often than their overhead counterparts. However, when repairs are required, they are lengthy and costly.
- Power Transfer Capability - Due to underground transmission lines inherent issues with heat dissipation typically underground transmission lines cannot transfer as much power as overhead with similar conductor sizes. In regions such as the southwest where dry warm conditions are prevalent, power transfer capability of underground transmission is significantly less than that of overhead transmission.

## 1. STUDY DESCRIPTION

---

### 1.1. OVERVIEW

The purpose of this document is to generate an indicative cost estimate to inform TEP and interested parties of the estimated construction costs for underground 138kV construction. It also provides information on operation, maintenance, and repair concerns for underground transmission lines. S&L developed the cost estimate for multiple segments of 138kV underground transmission line along a 5.5 mile long route based on an urban environment in central Tucson and assumed the crossing of a railroad and restricted access highway via trenchless installations.

## 2. UNDERGROUND CABLE SYSTEMS

---

XLPE Cable is the most common type of cable used for underground transmission lines being installed at transmission level voltages. XLPE cable systems have become the preferred underground cable system for underground cable installations in the United States. Therefore, XLPE has been selected as the cable system for this study.

### 2.1. SYSTEM AMPACITY RATINGS

When designing underground transmission lines, one of the most important concepts to consider is the ampacity of the cable. The largest impact to the ampacity is the thermal performance of the underground system as whole. The calculation for determining the allowable ampacity of the underground cable is complicated with many design factors that have effects on the thermal performance of the cable. These factors include items such as soil thermal resistivity, cable size, cable depth, and cable separation. At this early stage S&L has performed preliminary calculations to determine a conceptual ampacity to understand potential cost and planning of the project.

#### 2.1.1. Soil Thermal Resistivity

Soil thermal resistivity has a large impact on the allowable cable ampacity. The thermal resistivity is an important factor for design of underground electric cable systems. It is a measure of how a soil resists heat flow away from the cable. Due to this, thermal properties of the soils/backfill installed around the cable have a direct impact on cable ampacity. The entire area surrounding the cable can affect the ampacity, including changes in layers and materials around the cable. Concrete and asphalt placed on top of the cable would affect the rating of the cable, most likely in a negative way, dependent on their thermal resistivity.

#### 2.1.2. Cable Size

The conductor size of the cable has the most obvious impact to the ampacity of the cable. An increase in the conductor size has a direct correlation to an increase in ampacity. There is a limit to the allowable cable size. At present, 6000 kcmil is the largest conductor size used for XLPE type cables.

#### 2.1.3. Cable Depth

Depth of the cables has an impact on the ratings of the cable. The deeper the cable is in the soil, the more soil heat must move through to dissipate away from the cable. Typically, larger cables are required for deeper installations. By the requirements of the NESC (National Electric Safety Code) which has been



adopted by the State of Arizona as law, requires a minimum depth of the cables to ensure safety for the general public. This minimum depth, though most desirable to support a higher allowable ampacity of the cable cannot always be maintained. Existing underground infrastructure such as water lines, sewer lines, gas lines, communications line, and potentially other electrical lines all could effect the depth of the transmission line pushing the cable deeper affecting ampacity.

#### **2.1.4. Cable Separation**

Other cables in proximity can also generate heat and adversely affect the cable ampacity. This condition is called mutual heating. This can be reduced by increasing the separation of the cables. Optimal separation is determined by weighing the separation distance against the amount of excavation required. Increasing the separation too much would require larger excavation which in turn drives up project cost.

## **2.2. INSTALLATION METHODS**

There are multiple types of installations for an underground transmission line. These include:

1. Use of open trenches with installation of a duct bank
2. Use of open trenches for direct embedment
3. Trenchless type such as Horizontal Directional Drill (HDD) or jack and bore.

The most common method in the U.S. is duct bank-type installations. Duct banks are installed to provide mechanical protection for the cable, and to easily allow a cable to be upgraded in the future. Short lengths of a couple hundred feet of trench are opened at a time. For this project, S&L would recommend the duct bank installations where open trench is feasible and a jack and bore installation for the short distances under highways and railroad crossings.

There are multiple steps for installation of an underground transmission line. First, all necessary information should be acquired such as geotechnical studies which should include thermal analysis of the soil, existing underground utility locations and acquiring all permits required for the project. Secondly, the civil installation includes the excavation of the soil for the duct bank, installation of the duct bank described later, installation of the man vaults, backfilling the excavations with thermally corrective fill to the desired compaction and restoring the ground surface around the duct bank. Next contractors would mandrel the duct bank to ensure proper installation with no obstructions. Finally, the electrical construction includes the installation of all cables (electrical and communications), splicing, and grounding of the cables and other equipment. After the civil and electrical installations are complete, the system is tested before it is placed in operation.

### **2.2.1. Open Trench**

Open trench construction would consist of cutting the asphalt road or concrete sidewalk and utilizing excavation equipment to remove any sub-grade material and soil to the desired depth of the proposed duct bank. The excavated material would be removed for disposal or stockpiled for use as backfill after completion of the duct bank (provided the properties of the soil meet the design criteria). Excavations usually happen in sections to limit the amount of open trench; this would be determined during detailed design. In urban environments, which is the basis for this cost estimate, shoring would be utilized to keep excavations open and limit the width of the excavation. The expected construction width in urban areas is approximately 20 feet (Figure 2.1) for the trench, excavation and working space. The construction contractor would be required to provide traffic control devices such as jersey barriers, signage, and potentially flagman to ensure safety for workers and the public. When construction isn't present trench should be covered by steel plates.

**Figure 2-1 — Typical Urban Open Trench Construction**

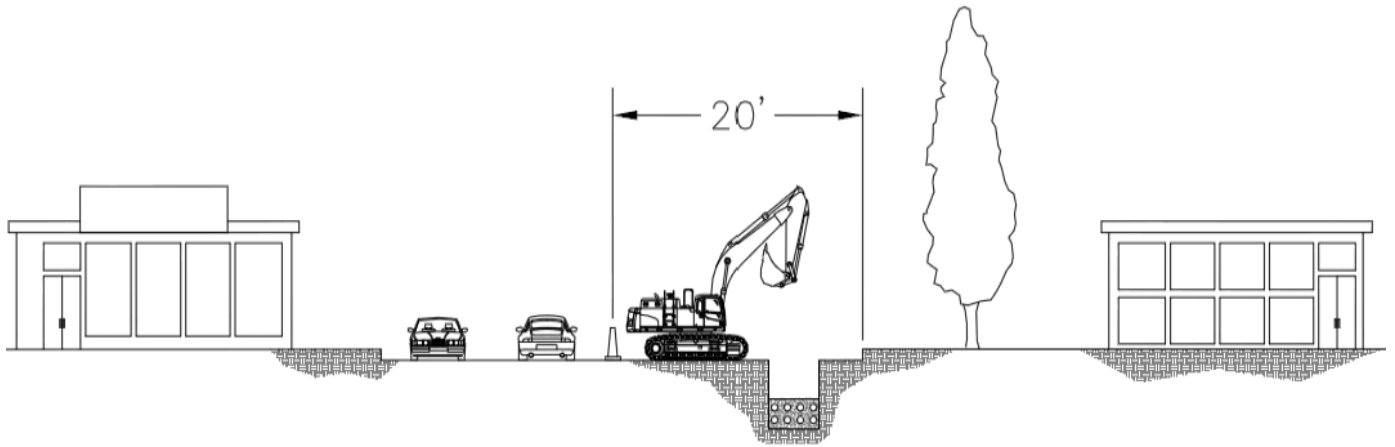

Once a portion of the trench is excavated and clear to the proper depth, polyvinyl chloride (PVC) duct would be placed into the open trench. Individual PVC ducts would be used to house each cable and/or communication wires to be installed. The ducts would be held in place utilizing plastic duct spacers to ensure all the required separation per the design are met (see figure 2.2). In an urban environment, utilities that cannot be relocated prior to the construction of the duct bank would increase construction cost and time. Existing utilities that must remain in the Right of Way (ROW) would be required to be supported during the open excavation and avoided by re-routing the duct bank or changing duct configuration to accommodate the existing infrastructure. These types of details would be determined during detailed design. Duct bank spacers are placed three to five feet apart to keep the PVC ducts in the desired configurations. The area would then be framed and filled with high strength thermally corrective concrete (see figure 2.3), with the top portion having a red dye added to identify danger during future excavation. After the concrete has hardened the trench is backfilled and the surface returned to pre-construction conditions.

**Figure 2-2 — Open Trench Spacers**



**Figure 2-3— Open Trench Concrete**



## 2.2.2. Trenchless Installation

There are two types of trenchless methods that are commonly utilized when open trenching may not be allowed. Horizontal Directional Drill (HDD) and jack and bore. Trenchless type installations are used in areas where open trench is not allowed such as highways, railroads, bodies of water, and other environmentally sensitive areas. For the urban environment in this estimate, jack and bore was used to cross under railroad and highway due to the short crossings, approximately 400 feet. Jack and bore installations consist of installing a non-metallic casing such as high-density polyethylene (HDPE), fiberglass or reinforced concrete pipe, and then installing the smaller ducts within the larger casing. Jack and bore can only be installed in a straight path.

Jack and bore must be installed via a send and receive pit excavated on either side of the crossing. Send pits are typically 30' to 40' long x 10' wide to the required depth of the bore plus 3' for the placement of equipment, approximately 16-18' deep. Depth may vary based upon existing utilities and any requirements of other entities such as ADOT or railroad owners. This size is required for the boring equipment and for placing the casings which are approximately 20' sections but vary dependent on send pit sizes. Receive pits are commonly smaller in size averaging 10' long x 10' wide to the same depth as the send pit. Due to the depth of the excavation shoring would be required to maintain the safety of all workers in the pit based on the assumption there would not be enough room to bench the excavation. The excavated material must also be considered for storage during the jack and bore process. In urban environments where construction area is restricted, excavated material is typically transported outside the construction area to be stored or disposed of while duct banks are installed. This can lead to an even larger area required for the jack and bore process. Casings can vary in size from 14 to 80+ inches in diameter, depending on project requirements.

Figure 2-4 — Jack and Bore – Send Pit



**Figure 2-5 — Jack and Bore – Equipment**



### **2.2.3. Vaults**

Man-vaults would be required along the route for cable installation, splicing, inspection, maintenance requirements and access for future repairs. Man-vault spacing, and location are determined by maximum cable reel length, cable pulling tensions, and side wall pressures. Typical distance between vaults is expected to be 1,500 to 2,500 feet for the XLPE cable. The size of man-vaults is based on the type of cable system installed. Typical dimensions for man vaults are between 25-35 feet long by 7-10 feet wide by 10-12 feet tall dependent on voltage. Excavations are expected to be 37 feet long by 12 feet wide by 12 - 16 feet deep dependent on existing infrastructure. Typically, man vaults are pre-cast and delivered to the site for installation. After installation, the over excavation is backfilled. A man vault typically houses cable and splices on one side of the vault allowing open space on the other side to work, cables are typically stacked 3-4 high dependent on system design. If the design of the underground line requires multiple cables per phase to maintain ampacity requirements multiple vaults per splice location would be required. These vaults will be placed in line, slightly offset, to minimize easement impacts. One phase cable set would enter the first vault while the second set would by-pass the first vault, then enter the second vault while the first phase cable set would by-pass the second vault. This would occur at every vault location.

**Figure 2-6 – Man Vault Placement**



**Figure 2-7 – Man Vault Backfill**



### 2.2.4. Cable Installation and Testing

After the civil portion of the underground installation (no cables placed in ducts at this time) is complete, the duct bank would be tested and cleaned by pulling a mandrel and swab through each of the ducts. This is done to ensure all ducts are concentric with correct clearance for cable, are clean of debris and are ready for cable pulling. Once each duct is cleared the cables can be installed. The typical cable pulling setup would be to set the reel of cable at one end of the pull and place a winch truck at the opposite end. Direction of pull between man vaults would be determined based on the direction that results in the lowest pulling or sidewall tensions. Once all the cables are pulled into a man-vault from each direction, splicing of the cable could commence. This process is repeated until all the cables have been pulled and spliced or terminated.

**Figure 2-8 – XLPE Cable Reel**



**Figure 2-9 – XLPE Cable Installation**



After completion of the installation, all splices and terminations of the cable must be tested before being placed in service. Testing includes a jacket integrity test using a specified DC voltage to ensure the jacket is continuous from end to end. Historically, an AC soak test would also be performed where the cable would be connected at rated voltage without load and left to “soak” for 24 hours. This enables the insulation to be stressed prior to current flow.

### **2.3. MAINTENANCE**

Underground transmission lines require routine maintenance to ensure the cables continue to operate with uninterrupted service. Maintenance is primarily visual inspection of terminations, splices, man vaults, arrestors, grounds, riser structures, and cables. This type of maintenance is dependent on the utility but is recommended every 6 to 12 months for standard maintenance and a higher intensity maintenance performed in five-year intervals. To accommodate for visual inspections, the line would have to be de-energized and lane closures maybe necessary to allow inspectors access into the vaults.

#### **2.3.1. Cable Failure and Repair**

Underground transmission lines, in general, are reliable. However, should a cable failure occur, the time to restore service can be lengthy. Overhead lines, utilizing standard material, can usually be placed back into service in a matter of days. On the other hand, underground transmission lines may be out of service for weeks to get qualified crews on site to repair or replace cable. If cable is not available or stored in a yard it could take months for repair as new cable would be ordered, which typically have long lead times. Accurately locating the cable failure is extremely important. Overhead line faults are relatively easy to identify and correct as visual inspections provide a quick analysis and plan for repair. Locating a failure for underground lines is much more difficult as visual inspection is nearly impossible. Therefore, other methods



are used to locate the failure(s). The most common method of locating a fault is to apply a capacitor discharge signal and detect return signal using an acoustical device.

Once the fault is located, a specialized contractor such as the cable manufacturer would need to make the repairs. Faults may be so great that the cable cannot be reused and depending on the level of failure, could fuse to the duct. In this case, if the duct has a spare, a new cable would need to be purchased, manufactured and pulled. If there is no spare position in the duct bank, then a replacement duct bank would need to be installed.

### 3. PRELIMINARY DESIGN

This assessment is based on a 5.5-mile route, broken out into multiple sections described below in table 1, in an urban location of central Tucson. Due to the location installation of the duct bank is proposed in the road, median, road shoulder, or sidewalk area dependent on location. S&L has assumed that most of the line would be installed in road median or road shoulder to minimize impacts to the travel lanes as much as possible. It is also assumed that most of the existing storm drains would be avoided by this placement limiting the amount of existing infrastructure interactions. At this stage, no surveys geotechnical studies within the project study area or other design support activities have been performed. A full list of assumptions is provided in section 4.

**Table 1 – Sections**

<b>Section</b>	<b>Description</b>
1	36 <sup>th</sup> to Silverlake
2	Silverlake to 22 <sup>nd</sup>
3	22 <sup>nd</sup> to Broadway
4	Broadway to 6 <sup>th</sup>
5	6 <sup>th</sup> to Speedway
6	Speedway to North UA Substation
7	North UA Substation to Grant

### 3.1. DESIGN INPUTS

**Table 2 – Preliminary Cable Data**

<b>CONDUCTOR SIZE</b>	6000 KCMIL
<b>CONDUCTOR MATERIAL</b>	COPPER,
<b>INSULATION TYPE</b>	CROSS LINKED POLYETHYLENE (XLPE)
<b>NUMBER OF CABLES PER PHASE</b>	2
<b>CABLE DIAMETER</b>	4.86 INCHES
<b>CABLE WEIGHT</b>	24.4 LB/FT
<b>MAXIMUM CABLE OPERATING TEMPERATURE</b>	90°C
<b>EMERGENCY TEMPERATURE</b>	105°C

Based on the cable size, it is expected that the duct bank would require 8” ducts to supply enough space for the specified cable. No spare cable will be installed for this project. S&L would recommend a spare duct for phase cables be installed in the event that catastrophic damage occurs in a duct, TEP can install a new cable without developing an entirely new duct bank. It is assumed the permanent right of way width required for the duct bank would be approximately 30 feet wide.

For communication wires and Ground Continuity Conductor (GCC), S&L recommends the use of 2” Schedule 40 conduits. A single 2” duct would be utilized for the installation of one 96 count single mode fiber optical cable for communication support for the transmission line. Two ducts would be utilized for the installation of a fiber optic cable that would be used for distributed temperature sensing fiber (DTS). The DTS would be used to monitor the temperature of the cables in the duct bank to ensure the protection of the cable. Two ducts would house the GCC to support the cable grounding method which would be finalized during detailed design. Finally, S&L recommends two additional 2” ducts to be installed as a spare in the event that there is damage to one of the 2” ducts. A total of seven 2” ducts are proposed for the transmission line.

S&L identified, using preliminary GIS data that the underground transmission line route could cross up to 40 sewer lines and 70 water lines along the 5.5-mile route. During detailed design of the 138kV underground transmission line, it is expected to encounter storm water, communications, and gas lines., This would require changes in configuration and depth of the underground transmission line or relocation of the existing utilities which will result in higher installation cost. It is expected that these interferences will be encountered multiple time on the project due to the urban nature of the route.

### 3.2. ELECTRICAL DESIGN

#### 3.2.1. AMPACITY

For the purposes of this cost estimate, a 6000 kcmil two cable per phase installation was chosen in order to meet all ampacity requirements set forth by the client. A preliminary cable ampacity calculation has been performed to determine conceptual cable ampacity characteristics. To perform this work, CYMCAP, a cable ampacity program developed by Eaton was used to model the underground transmission layout. The modeling accounts for all material placed around the cable as well as the potential depth and configuration of duct banks/bores along the route. If determined during the detailed modeling of the system that the ampacity is not met, more conductor area would be required; this may potentially require additional cables per phase and updates to the design. This could have significant impacts to the design, increasing the duct bank size

and requirement of additional materials. A total of 8 unique installations were evaluated to determine ampacity, these include open trench duct bank, and jack and bore. See Table 2 for maximum steady state ampacity results.

A preliminary native soil thermal resistivity of 2.79°C-m/W was utilized for the ampacity calculation. This value was determined per a geotechnical investigation that was conducted for a project at Irvington Yard 138kV Substation provided by TEP. This sample investigation is located approximately 3.25 miles from the southern most edge of the study area for this project. It is critical to understand that soil characteristics change and it is recommended that these tests are performed at approximately 1500 foot intervals along the route. If the soils thermal resistivity is higher than expected, the ampacity will decrease as described in section 1. Thermal resistivity for the duct bank concrete (duct bank encasement and red dyed) was assumed to be 0.65°C-m/W and the thermally approved backfill was assumed to be 0.90°C-m/W.

Soil temperatures for the duct bank and the jack and bore installations were determined utilizing data retrieved from the National Water and Climate Center (NWCC). The NWCC provides soil temperature data at a maximum depth of 40 inches. The worst-case annual ground temperature per the NWCC at a depth of 40 inches is 28.8°C. Soil temperature at a depth of 60 feet was determined utilizing data retrieved from "Henry's Map," which is located on the Environmental Protection Agency website. The average temperature of shallow groundwater is approximately 22.2°C. For conservatism, this value was increased to 25°C for the purposes of this calculation.

At the request of TEP the minimum required ampacity for the line will be 1584A continuous rating, but TEP would prefer that the underground transmission line has the same capacity as TEP's standard 138kV overhead transmission line utilizing 954 ACSS conductor which is 2264A. It is assumed there is a load factor for the cable of 0.75 per TEP. Table 2 below provides a summary of the preliminary ampacity calculation performed by S&L.

**Table 3 – Maximum Steady State Ampacity at Rated Temperature (90°C)**

Installation Number	Cable Size	Description	Required Ampacity Per Phase (A)	Preferred Ampacity Per Phase (A)	Max Ampacity Per Phase at Rated Temp (A)
1	6000 kcmil	Duct Bank – 1 Cable/Phase – 3ft Depth	1584	2264	1892.5
2	6000 kcmil	Duct Bank – 2 Cables/Phase – 3ft Depth	1584	2264	3045.6
3	6000 kcmil	Duct Bank – 1 Cable/Phase – 10ft Depth	1584	2264	1552.3
4	6000 kcmil	Duct Bank – 2 Cables/Phase – 10ft Depth	1584	2264	2341.6
5	6000 kcmil	Jack & Bore – 1 Cable/Phase – 15ft Depth	1584	2264	1258.1
6	6000 kcmil	Jack & Bore –2 Cables/Phase –15ft Depth	1584	2264	2316.8
7	5000 kcmil	Jack & Bore– 2 Cables/Phase –15ft Depth	1584	2264	2025.0
8	5000 kcmil	Duct Bank – 2 Cables/Phase-10ft Depth	1584	2264	2053.0

The allowable ampacity of an underground transmission line is restricted by the section of the line with the lowest allowable ampacity. Given the cable requirements set forth, a single 6000 kcmil cable per phase installation will not meet ampacity requirements for all required installation configurations, mainly when the cable is 10 plus feet deep. Therefore, it should be assumed at minimum a two cable per phase installation will be required.

S&L evaluated 2 cables per phase installations for both 5000 kcmil and 6000 kcmil cables for the most critical cases (jack and bore and deep duct bank), both installations meet the minimum required ampacity of 1584A. A 5000 kcmil two cables per phase installation will allow a maximum ampacity 2053.0A while a 6000 kcmil two cable per phase installation will allow a maximum ampacity of 2316.8A. The benefit of selecting a 6000 kcmil cable over a 5000 kcmil would be an improvement in ampacity of 263.8A and meeting the preferred ampacity. The benefit of a 5000 kcmil cable would be a lower cost as well as being more common conductor size in the industry.

If a jack and bore is not utilized on this project, a 5000 kcmil two cable per phase installation will allow a maximum ampacity of 2053.0A and a 6000 kcmil two cable per phase installation will allow a maximum ampacity of 2341.6A.

### 3.2.2. CHARGING CURRENT

Cable charging current was calculated in order to better understand the electrical characteristics of the transmission line. Charging current is a capacitive loss that occurs due to the layer of insulation surrounding the underground cable. The charging current calculation was completed using an S&L internal design calculation. In addition, the cables were modeled in CYMCAP in a typical duct bank configuration and charging current was analyzed and compared to the S&L calculation results. See Table 3 for the results of the cable charging current calculation.

**Table 4 – Charging Current – Calculated Result**

Description	Result (A)
S&L Calculation - Total Charging Current – Per Phase	194.678
CYMCAP - Total Charging Current – Per Phase	194.319

Based on the ampacity requirements specified by the client, ampacity is either 1585 amps minimum, or 2264 amps preferred. With a result of 195 amps, the charging current makes up 12.3% – 8.6% of the total current. The full impacts of the cable’s shunt capacitance and charging current must be studied from a system impact perspective to fully understand the effects on voltage regulation, system efficiency and power flow. In addition, the charging capacitance needs to be considered when developing the line protective relay settings.

### 3.2.3. MAGNETIC FIELD

In addition to ampacity and charging current, a magnetic field calculation was also performed. Magnetic field was analyzed using CYMCAP and assumes a typical installation case which provides both a conservatively result for the strength of magnetic field based of minimal depth of installation and is expected to be used for most of the route. Results are provided for both the preferred client ampacity of 2264A per phase as well as the minimum allowable ampacity of 1584A per phase. See Table 4 and Table 5 for the EMF results.

**Table 5 – 1584A Magnetic Field Results**

Description	Distance from Center of Duct Bank (ft)	Magnetic Field (mG)
Maximum Magnetic Field	0	208.837

**Figure 3-1 – 1584A Magnetic Field Results**

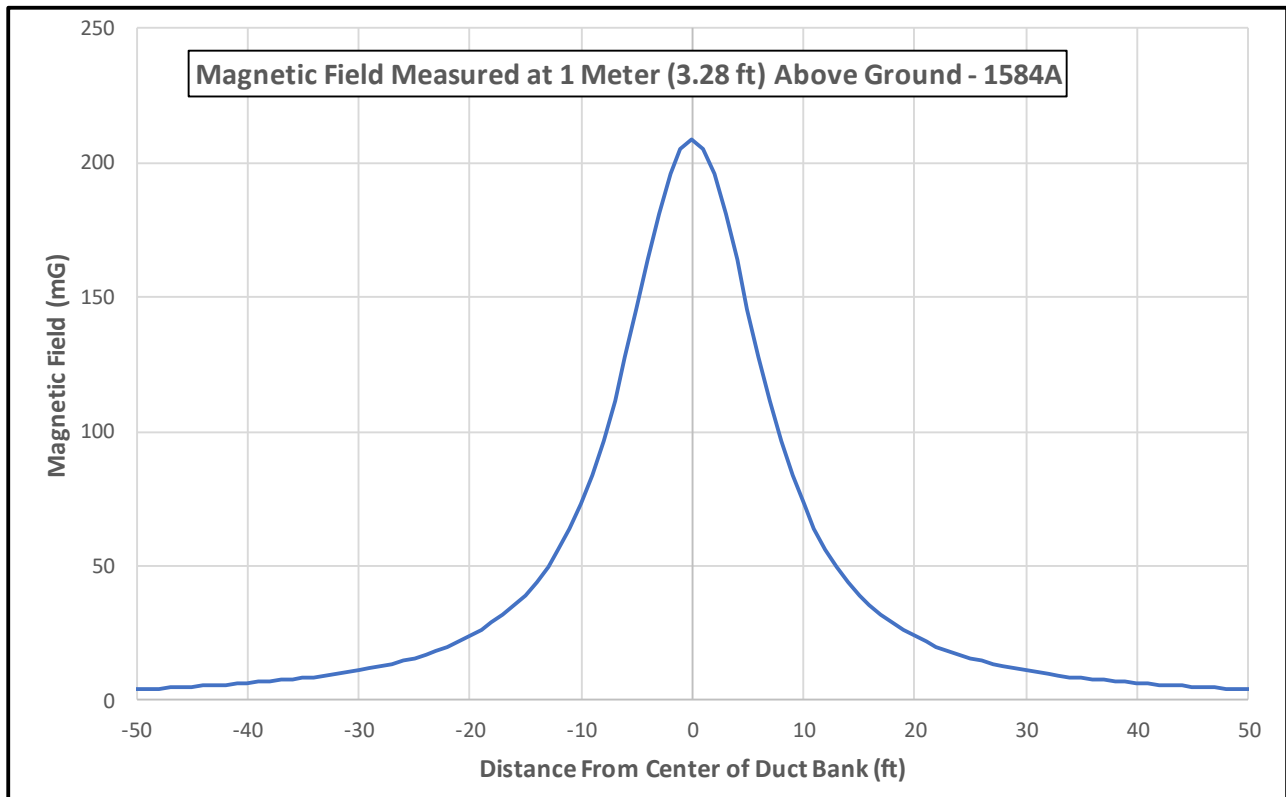

**Table 6 – 2264A Magnetic Field Results**

Description	Distance from Center of Duct Bank (ft)	Magnetic Field (mG)
Maximum Magnetic Field	0	298.678

**Figure 3-2 – 2264A Magnetic Field Results**

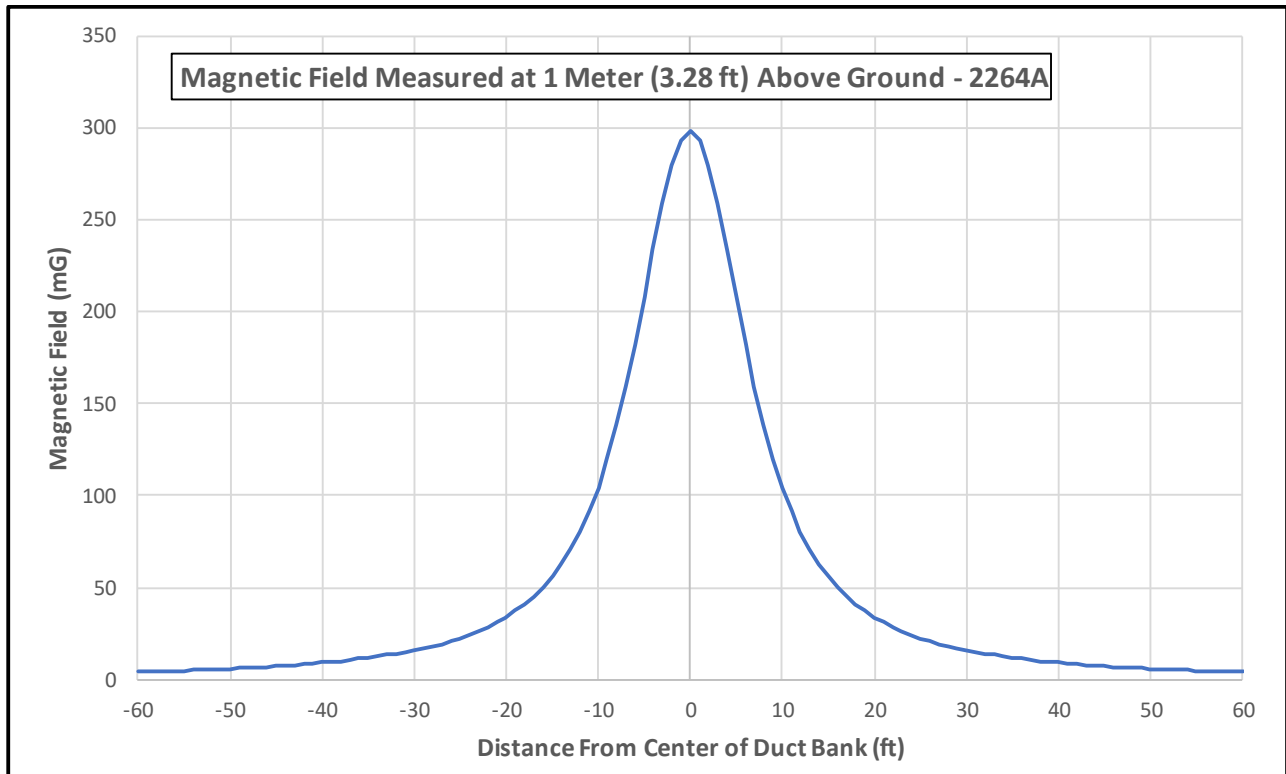

**3.3. OPEN CUT TRENCH PARAMETERS**

Since data has not been gathered for underground infrastructure along the route, S&L assumes the average depth of the duct bank would be at minimum, 3 feet to the top of the duct bank. Most existing underground infrastructure would be crossed by open trench except when in designated road jack and bore crossings. The duct bank would have ten 8” PVC ducts for cables and four 2” PVC ducts. Below is a preliminary representation of the proposed duct bank design.

**Figure 3-3 — Preliminary Duct Bank Layout**

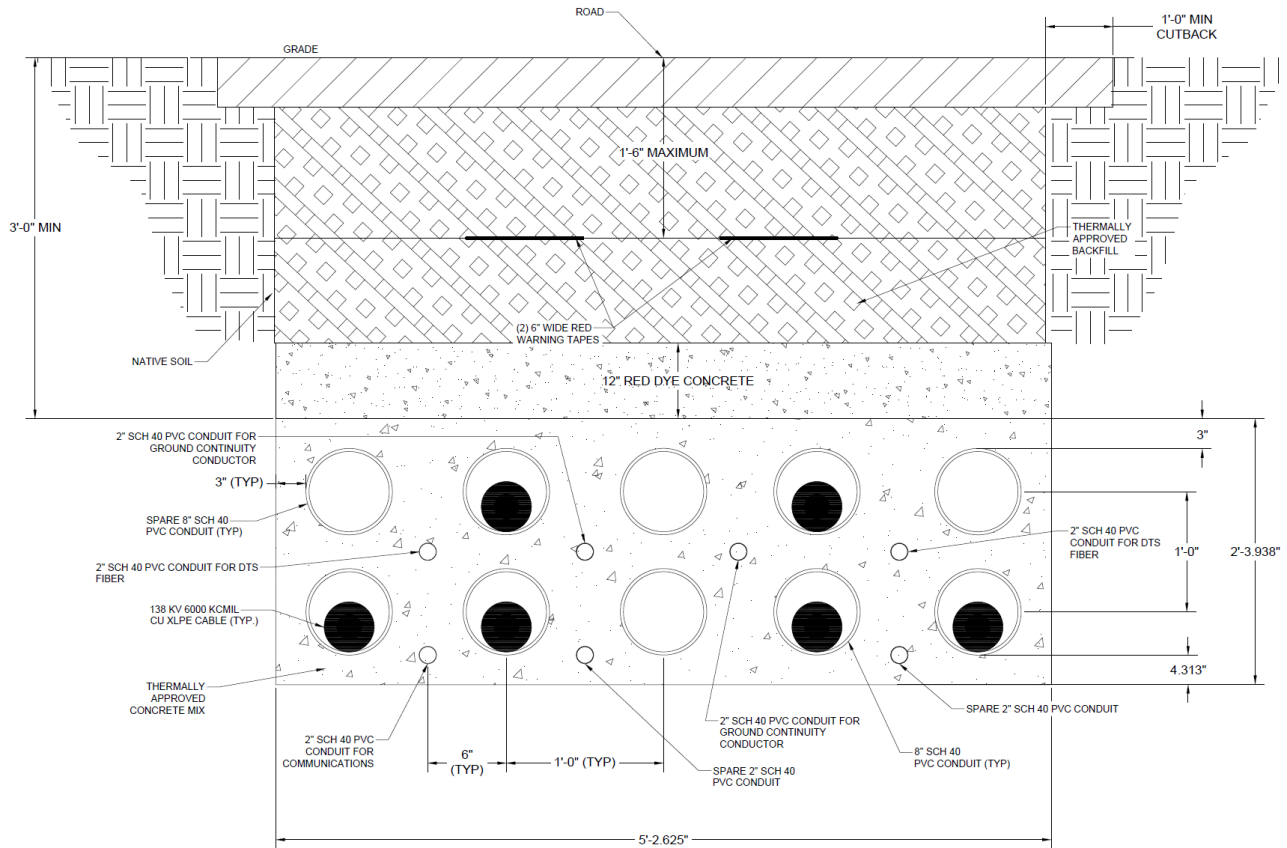

**3.4. TRENCHLESS DESIGN PARAMETERS**

It is expected that trenchless installations would be required under the highway and railroad crossings. For this study, it was assumed that there would be one crossing requiring a jack and bore, approximately 400-ft in length. S&L has estimated the bore casing would be 42” in diameter to support the duct installation. Due to the requirement of a minimum of 2 cables per phase multiple bores will be required. It is expected the boring would be filled with thermal grout such as bentonite to aid in heat dissipation. Depth of the bore would be determined during detailed design once all existing infrastructure and other required inputs clarify the design.

Figure 3-4 — Preliminary Bore Layout

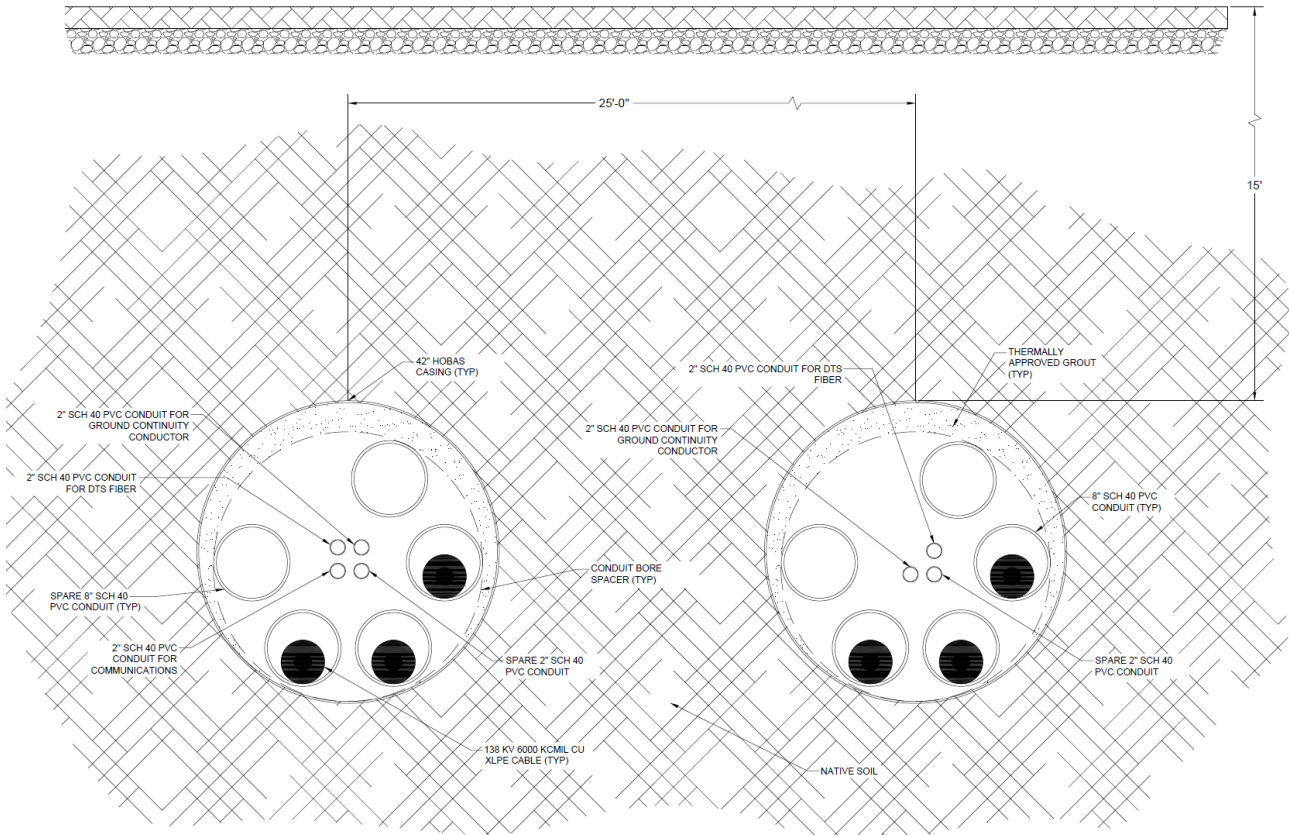



## 4. COST ESTIMATE

### 4.1. COST ESTIMATE ASSUMPTIONS

This cost estimate is based on standard pricing and/or pricing attained for a 5.5-mile-long underground line in urban, central Tucson. There are many factors that can affect the overall cost of the transmission line.

Below is a list of assumptions for this estimate:

1. Costs are based on 2020 costs. No escalation is included. Therefore, cost of materials can fluctuate and affect the overall estimate.
2. Cost estimate does not include costs associated with environmental and ROW acquisition. This report was prepared to examine the feasibility and cost of undergrounding. The estimate provided may increase based upon permitting and ROW acquisition.
3. Subsurface Conditions - Preliminary Sewer and water lines were considered in this estimate. Existing infrastructure can have major effects on construction and therefore would have significant impacts on cost. At this stage S&L has assumed a 6' deep trench typically and 15' deep trenchless installations would be acceptable. If additional crossing such as communications, gas, electrical are discovered during design this will create additional design and construction cost during the construction of the project.
4. Soil types, such as rock, have impacts on cost. At this stage S&L assumed no rock or caliche would be encountered within the study area.
5. The City may have special requirements that may impact the current restoration estimate assumptions. S&L has assumed the project would only require repair of the removed asphalt, curbs, and sidewalks. If more is required by the City, this would increase the cost.
6. Estimate does not include any environmental costs. This could increase costs based on level of environmental requirements for the project. This would be defined in the detailed design stage of the project. It is important to understand this could have a significantly larger impact than overhead transmission lines. Due to the fact that trenching would be required throughout the route underground transmission lines have a much larger impact and therefore could have significant cost impact (permitting and mitigation) if environmental or archeological areas are encountered.
7. Assumes single point or cross bonding scheme.
8. Cost Estimate assumes two 6000kcmil cables per phase.
9. Estimate does not include any costs for right of way, easement acquisition, or temporary construction easements.
10. Duct installation cost includes excavation, shoring, duct placement, placement of concrete (including red dye), and compaction of soil above. Cost of repaving is separate.
11. No spare material has been included, unless identified otherwise.
12. Only one railroad crossing requiring a jack and bore installation was assumed for the study.
13. It is assumed 7.8% sales tax has been included on material.
14. A 20% contingency due to unknowns is included.
15. Materials used in the cost estimate meet all applicable industry standards.
16. Construction would be performed by qualified and experienced contractors.
17. S&L assumes 10 ducts for cable and 7 ducts for communications, ground continuity conductors, and

spares.

18. Vaults are assumed to be installed approximately every 2,000 feet.
19. Asphalt repair assumes 8' wide repair.
20. Excavation assumes 30% swell of soils for hauling purposes.
21. Assumes civil contractor can install 100' of duct a day
22. Assumed Jack and bore across highway and rail road. 2 – 42" hobas pipe
23. Assumes 2 vaults per splice (one per phase cable).

## 4.2. COST ESTIMATE

The transmission line was broken up into 7 sections in order to perform a cost estimate for the underground transmission line. In addition, a section titled "Engineering and Commissioning" accounts for costs that are lump sum or design, design support, and commissioning work. Sections 1 and 7 include costs related to the riser structures at the beginning and end of the underground portion of the line. These costs include the materials and labor for the installation of the terminations, arrestors, and splices. Section 3 accounts for a jack and bore under Aviation Parkway and Union Pacific Railroad. See Table 6 for a cost estimate summary broken down by section, as well as the total cost. See Appendix A for a detailed breakdown of costs by section.

**Table 7 – Cost Estimate Summary**

Section	Cost (\$)	Cost (\$+20%)	Section Length (ft)	Cost (\$/ mile)	Cost (\$/mile +20%)
1	\$6,941,834.99	\$8,330,201.99	3150	\$11,635,837.70	\$13,963,005.25
2	\$5,544,858.27	\$6,653,829.93	2886	\$10,144,439.25	\$12,173,327.10
3	\$20,195,682.19	\$24,234,818.63	9190	\$11,603,177.58	\$13,923,813.10
4	\$4,762,359.61	\$5,714,831.53	2330	\$10,791,956.54	\$12,950,347.85
5	\$6,582,576.50	\$7,899,091.80	2998	\$11,593,063.35	\$13,911,676.02
6	\$8,511,807.52	\$10,214,169.02	4247	\$10,582,138.85	\$12,698,566.62
7	\$9,309,326.06	\$11,171,191.27	4407	\$11,153,447.15	\$13,384,136.59
Engineering and Commissioning	\$4,178,041.60	\$5,013,649.92			
Total	\$61,848,445.15	\$74,218,134.18	29208	\$11,180,491.32	\$13,416,589.58

## 5. CONCLUSIONS

TEP's typical installation cost for a 138kV overhead transmission line is approximately \$1 million a mile for a design in an urban environment. Based on the underground estimate developed in this analysis, an underground transmission line would cost approximately \$13.5 million a mile or about 13.5 times the cost of an overhead transmission line.

## **6.APPENDIX A – SECTION COST SUMMARIES**

---

Section 1 - 36th to Silverlake

ITEM	DESCRIPTION	QUANTITY	MATERIAL UNIT PRICE (\$/UNIT)	TOTAL MATERIAL COST (\$)	LABOR UNIT PRICE (\$ UNIT)	TOTAL LABOR COST (\$)	TOTAL OVERALL COST (\$)
<b>EARTHWORK AND DUCT BANK INSTALLATION</b>							
1	8 inch PVC Couduit, Per ft	31500	\$8.25	\$259,875.00	\$0.00	\$0.00	\$259,875.00
2	2 inch PVC Couduit, Per ft	22100	\$1.50	\$33,150.00	\$0.00	\$0.00	\$33,150.00
3	Conduit Duct Spacers, Each	1050	\$30.00	\$31,500.00	\$15.00	\$15,750.00	\$47,250.00
4	Man Vault, Each	4	\$45,000.00	\$180,000.00	\$25,000.00	\$100,000.00	\$280,000.00
5	Duct Installation, Per ft	3200	\$100.00	\$320,000.00	\$175.00	\$560,000.00	\$880,000.00
6	Additional Excavation due to UG Crossing, cubic foot	21120	\$2.00	\$42,240.00	\$2.00	\$42,240.00	\$84,480.00
7	Thermal Backfill, cubic foot	89500	\$3.50	\$313,250.00	\$2.00	\$179,000.00	\$492,250.00
8	Haul Away, cubic ft	172100	\$1.00	\$172,100.00	\$2.00	\$344,200.00	\$516,300.00
9	Asphalt Replacement, sq ft	26600	\$5.50	\$146,300.00	\$5.00	\$133,000.00	\$279,300.00
10	Sidewalk/Curb Replacement, ft	11	\$100.00	\$1,100.00	\$40.00	\$440.00	\$1,540.00
11	Landscape Restoration, sq ft	1430	\$2.00	\$2,860.00	\$3.00	\$4,290.00	\$7,150.00
12	Utility Relocation, ft	160	\$100.00	\$16,000.00	\$100.00	\$16,000.00	\$32,000.00
13	Steel plating, days	32	\$480.00	\$15,360.00	\$0.00	\$0.00	\$15,360.00
14	Traffic Control, days	37	\$1,800.00	\$66,600.00	\$0.00	\$0.00	\$66,600.00
<b>TRENCHLESS INSTALLATION (JACK AND BORE)</b>							
15	Jack and Bore, Per ft	0	\$575.00	\$0.00	\$575.00	\$0.00	\$0.00
16	Mobilization / Demobilization, lot	0	\$0.00	\$0.00	\$75,000.00	\$0.00	\$0.00
17	Bore Spacer, each	0	\$540.00	\$0.00	\$100.00	\$0.00	\$0.00
18	Bore Grout, cubic ft	0	\$3.50	\$0.00	\$2.00	\$0.00	\$0.00
19	Haul Away jack and bore, cubic ft	0	\$1.00	\$0.00	\$2.00	\$0.00	\$0.00
20	Excavation Pit Soil Removal, Replacement and Compaction, cubic ft	0	\$1.00	\$0.00	\$2.00	\$0.00	\$0.00
21	Asphalt Replacement, sq ft	0	\$5.50	\$0.00	\$5.00	\$0.00	\$0.00
22	Shoring, per sq ft	0	\$15.00	\$0.00	\$50.00	\$0.00	\$0.00
23	Traffic Control, days	0	\$1,800.00	\$0.00	\$0.00	\$0.00	\$0.00
24	Steel plating, days	0	\$480.00	\$0.00	\$0.00	\$0.00	\$0.00
<b>CABLE AND ACCESSORIES</b>							
25	XLPE Cable, per ft	18900	\$120.00	\$2,268,000.00	\$0.00	\$0.00	\$2,268,000.00
26	Spare XLPE Cable on reel, per ft	0	\$120.00	\$0.00	\$0.00	\$0.00	\$0.00
27	Terminators, each	6	\$7,200.00	\$43,200.00	\$20,000.00	\$120,000.00	\$163,200.00
28	Spare Terminators, each	0	\$7,200.00	\$0.00	\$0.00	\$0.00	\$0.00
29	Arresters, each	6	\$2,500.00	\$15,000.00	\$2,000.00	\$12,000.00	\$27,000.00
30	Spare Arrester, each	0	\$2,500.00	\$0.00	\$0.00	\$0.00	\$0.00
31	Splices, each	12	\$8,000.00	\$96,000.00	\$13,500.00	\$162,000.00	\$258,000.00
32	Racking for Vaults, each	4	\$40,000.00	\$160,000.00	\$0.00	\$0.00	\$160,000.00
33	Grounding System for Vault, each	4	\$4,000.00	\$16,000.00	\$3,000.00	\$12,000.00	\$28,000.00
34	Grounding System for Structure, each	1	\$3,500.00	\$3,500.00	\$1,500.00	\$1,500.00	\$5,000.00
35	Cable Clamps, each	168	\$100.00	\$16,800.00	\$150.00	\$25,200.00	\$42,000.00
36	Continuity Conductors, per ft	6300	\$5.96	\$37,548.00	\$0.00	\$0.00	\$37,548.00
37	Cable pulling, grounding, days	43	\$0.00	\$0.00	\$9,000.00	\$387,000.00	\$387,000.00
38	Jacket integrity test, per section	0	\$0.00	\$0.00	\$2,000.00	\$0.00	\$0.00
39	Discharge/Withstand Test, lot	0	\$0.00	\$0.00	\$120,000.00	\$0.00	\$0.00
<b>FIBER OPTIC</b>							
40	Fiber Optic Cable, per ft	4000	\$1.50	\$6,000.00	\$0.00	\$0.00	\$6,000.00
41	Hand Vaults for Fiber, each	2	\$700.00	\$1,400.00	\$1,000.00	\$2,000.00	\$3,400.00
42	Excavation for Hand Vaults & Haul away, cubic ft	140	\$1.00	\$140.00	\$3.00	\$420.00	\$560.00
43	Sidewalk/Curb Replacement, ft	20	\$100.00	\$2,000.00	\$40.00	\$800.00	\$2,800.00
44	Fiber Optic Cable splices, each	4	\$1,000.00	\$4,000.00	\$4,000.00	\$16,000.00	\$20,000.00
45	Temp. Sensing Fiber, ft	4000	\$1.50	\$6,000.00	\$0.00	\$0.00	\$6,000.00
46	Temp. Sensing Fiber System, lot	0	\$115,000.00	\$0.00	\$100,000.00	\$0.00	\$0.00
<b>TERMINATION (RISER STRUCTURES)</b>							
47	Structure, each	1	\$90,000.00	\$90,000.00	\$50,000.00	\$50,000.00	\$140,000.00
48	Foundation, each	1	\$35,000.00	\$35,000.00	\$0.00	\$0.00	\$35,000.00
<b>ENGINEERING/ MANAGEMENT/ MISC.</b>							
49	Engineering, lot	0	\$0.00	\$0.00	\$1,200,000.00	\$0.00	\$0.00
50	Geotechnical Including Thermal, per bore	3	\$0.00	\$0.00	\$4,600.00	\$13,800.00	\$13,800.00
51	Underground Utility Survey, lot	0	\$0.00	\$0.00	\$700,000.00	\$0.00	\$0.00
52	Construction Management, lot	0	\$0.00	\$0.00	\$625,000.00	\$0.00	\$0.00
53	Mobilization / Demobilization, lot	0	\$0.00	\$0.00	\$450,000.00	\$0.00	\$0.00
54	Permitting	0	\$0.00	\$0.00	\$0.00	\$0.00	\$0.00
55	Environmental Compliance & Monitoring	0	\$0.00	\$0.00	\$0.00	\$0.00	\$0.00
<b>SUMMARY</b>							
	Sales Tax (7.8%)			\$343,271.99			
	Summary of Cost			\$4,744,194.99		\$2,197,640.00	\$6,941,834.99
	Summary of Cost with Contingancy (20%)			\$5,693,033.99		\$2,637,168.00	\$8,330,201.99
<b>NOTES</b>							

- 1 Section Length is assumed to be 0.60 miles (3,150 ft)
- 2 4 water pipe crossing
- 3 2 sewer pipe crossing

Section 2 - Silverlake to 22nd

ITEM	DESCRIPTION	QUANTITY	MATERIAL UNIT PRICE (\$/UNIT)	TOTAL MATERIAL COST (\$)	LABOR UNIT PRICE (\$ UNIT)	TOTAL LABOR COST (\$)	TOTAL OVERALL COST (\$)
<b>EARTHWORK AND DUCT BANK INSTALLATION</b>							
1	8 inch PVC Couduit, Per ft	28900	\$8.25	\$238,425.00	\$0.00	\$0.00	\$238,425.00
2	3 inch PVC Couduit, Per ft	20300	\$1.50	\$30,450.00	\$0.00	\$0.00	\$30,450.00
3	Conduit Duct Spacers, Each	970	\$30.00	\$29,100.00	\$15.00	\$14,550.00	\$43,650.00
4	Man Vault, Each	2	\$45,000.00	\$90,000.00	\$25,000.00	\$50,000.00	\$140,000.00
5	Duct Installation, Per ft	2900	\$100.00	\$290,000.00	\$175.00	\$507,500.00	\$797,500.00
6	Additional Excavation due to UG Crossing, cubic foot	35200	\$2.00	\$70,400.00	\$2.00	\$70,400.00	\$140,800.00
7	Thermal Backfill, cubic foot	66600	\$3.50	\$233,100.00	\$2.00	\$133,200.00	\$366,300.00
8	Haul Away, cubic ft	142300	\$1.00	\$142,300.00	\$2.00	\$284,600.00	\$426,900.00
9	Asphalt Replacement, sq ft	14500	\$5.50	\$79,750.00	\$5.00	\$72,500.00	\$152,250.00
10	Sidewalk/Curb Replacement, ft	1275	\$100.00	\$127,500.00	\$40.00	\$51,000.00	\$178,500.00
11	Landscape Restoration, sq ft	12750	\$2.00	\$25,500.00	\$3.00	\$38,250.00	\$63,750.00
12	Utility Relocation, ft	245	\$100.00	\$24,500.00	\$100.00	\$24,500.00	\$49,000.00
13	Steel plating, days	29	\$480.00	\$13,920.00	\$0.00	\$0.00	\$13,920.00
14	Traffic Control, days	34	\$1,800.00	\$61,200.00	\$0.00	\$0.00	\$61,200.00
<b>TRENCHLESS INSTALLATION (JACK AND BORE)</b>							
15	Jack and Bore, Per ft	0	\$575.00	\$0.00	\$575.00	\$0.00	\$0.00
16	Mobilization / Demobilization, lot	0	\$0.00	\$0.00	\$75,000.00	\$0.00	\$0.00
17	Bore Spacer, each	0	\$540.00	\$0.00	\$100.00	\$0.00	\$0.00
18	Bore Grout, cubic ft	0	\$3.50	\$0.00	\$2.00	\$0.00	\$0.00
19	Haul Away jack and bore, cubic ft	0	\$1.00	\$0.00	\$2.00	\$0.00	\$0.00
20	Excavation Pit Soil Removal, Replacement and Compaction, cubic ft	0	\$1.00	\$0.00	\$2.00	\$0.00	\$0.00
21	Asphalt Replacement, sq ft	0	\$5.50	\$0.00	\$5.00	\$0.00	\$0.00
22	Shoring, per sq ft	0	\$15.00	\$0.00	\$50.00	\$0.00	\$0.00
23	Traffic Control, days	0	\$1,800.00	\$0.00	\$0.00	\$0.00	\$0.00
24	Steel plating, days	0	\$480.00	\$0.00	\$0.00	\$0.00	\$0.00
<b>CABLE AND ACCESSORIES</b>							
25	XLPE Cable, per ft	17400	\$120.00	\$2,088,000.00	\$0.00	\$0.00	\$2,088,000.00
26	Spare XLPE Cable on reel, per ft	0	\$120.00	\$0.00	\$0.00	\$0.00	\$0.00
27	Terminators, each	0	\$7,200.00	\$0.00	\$9,000.00	\$0.00	\$0.00
28	Spare Terminators, each	0	\$7,200.00	\$0.00	\$0.00	\$0.00	\$0.00
29	Arresters, each	0	\$2,500.00	\$0.00	\$2,000.00	\$0.00	\$0.00
30	Spare Arrester, each	0	\$2,500.00	\$0.00	\$0.00	\$0.00	\$0.00
31	Splices, each	6	\$3,600.00	\$21,600.00	\$13,500.00	\$81,000.00	\$102,600.00
32	Racking for Vaults, each	2	\$40,000.00	\$80,000.00	\$0.00	\$0.00	\$80,000.00
33	Grounding System for Vault, each	2	\$4,000.00	\$8,000.00	\$3,000.00	\$6,000.00	\$14,000.00
34	Grounding System for Structure, each	0	\$3,500.00	\$0.00	\$1,500.00	\$0.00	\$0.00
35	Cable Clamps, each	36	\$100.00	\$3,600.00	\$150.00	\$5,400.00	\$9,000.00
36	Continuity Conductors, per ft	5800	\$5.96	\$34,568.00	\$0.00	\$0.00	\$34,568.00
37	Cable pulling, grounding, days	21.5	\$0.00	\$0.00	\$9,000.00	\$193,500.00	\$193,500.00
38	Jacket integrity test, per section	0	\$0.00	\$0.00	\$2,000.00	\$0.00	\$0.00
39	Discharge/Withstand Test, lot	0	\$0.00	\$0.00	\$120,000.00	\$0.00	\$0.00
<b>FIBER OPTIC</b>							
40	Fiber Optic Cable, per ft	3000	\$1.50	\$4,500.00	\$0.00	\$0.00	\$4,500.00
41	Hand Vaults for Fiber, each	1	\$700.00	\$700.00	\$1,000.00	\$1,000.00	\$1,700.00
42	Excavation for Hand Vaults & Haul away, cubic ft	70	\$1.00	\$70.00	\$3.00	\$210.00	\$280.00
43	Sidewalk/Curb Replacement, ft	10	\$100.00	\$1,000.00	\$40.00	\$400.00	\$1,400.00
44	Fiber Optic Cable splices, each	2	\$1,000.00	\$2,000.00	\$4,000.00	\$8,000.00	\$10,000.00
45	Temp. Sensing Fiber, ft	3000	\$1.50	\$4,500.00	\$0.00	\$0.00	\$4,500.00
46	Temp. Sensing Fiber System, lot	0	\$115,000.00	\$0.00	\$100,000.00	\$0.00	\$0.00
<b>TERMINATION (RISER STRUCTURES)</b>							
47	Structure, each	0	\$90,000.00	\$0.00	\$50,000.00	\$0.00	\$0.00
48	Foundation, each	0	\$35,000.00	\$0.00	\$0.00	\$0.00	\$0.00
<b>ENGINEERING/ MANAGEMENT/ MISC.</b>							
49	Engineering, lot	0	\$0.00	\$0.00	\$1,200,000.00	\$0.00	\$0.00
50	Geotechnical Including Thermal, per bore	2	\$0.00	\$0.00	\$4,600.00	\$9,200.00	\$9,200.00
51	Underground Utility Survey, lot	0	\$0.00	\$0.00	\$700,000.00	\$0.00	\$0.00
52	Construction Management, lot	0	\$0.00	\$0.00	\$625,000.00	\$0.00	\$0.00
53	Mobilization / Demobilization, lot	0	\$0.00	\$0.00	\$450,000.00	\$0.00	\$0.00
54	Permitting	0	\$0.00	\$0.00	\$0.00	\$0.00	\$0.00
55	Environmental Compliance & Monitoring	0	\$0.00	\$0.00	\$0.00	\$0.00	\$0.00
<b>SUMMARY</b>							
	Sales Tax (7.8%)			\$288,965.27			
	Summary of Cost			\$3,993,648.27		\$1,551,210.00	\$5,544,858.27
	Summary of Cost with Contingancy (20%)			\$4,792,377.93		\$1,861,452.00	\$6,653,829.93
<b>NOTES</b>							

- 1 Section Length is assumed to be 0.54 miles (2866 ft)
- 2 6 water pipe crossing
- 3 4 sewer pipe crossing

Section 3 - 22nd Broadway

ITEM	DESCRIPTION	QUANTITY	MATERIAL UNIT PRICE (\$/UNIT)	TOTAL MATERIAL COST (\$)	LABOR UNIT PRICE (\$ UNIT)	TOTAL LABOR COST (\$)	TOTAL OVERALL COST (\$)
<b>EARTHWORK AND DUCT BANK INSTALLATION</b>							
1	8 inch PVC Conduit, Per ft	91900	\$8.25	\$758,175.00	\$0.00	\$0.00	\$758,175.00
2	3 inch PVC Conduit, Per ft	64400	\$1.50	\$96,600.00	\$0.00	\$0.00	\$96,600.00
3	Conduit Duct Spacers, Each	3070	\$30.00	\$92,100.00	\$15.00	\$46,050.00	\$138,150.00
4	Man Vault, Each	10	\$45,000.00	\$450,000.00	\$25,000.00	\$250,000.00	\$700,000.00
5	Duct Installation, Per ft	9200	\$100.00	\$920,000.00	\$175.00	\$1,610,000.00	\$2,530,000.00
6	Additional Excavation due to UG Crossing, cubic foot	133760	\$2.00	\$267,520.00	\$2.00	\$267,520.00	\$535,040.00
7	Thermal Backfill, cubic foot	245500	\$3.50	\$859,250.00	\$2.00	\$491,000.00	\$1,350,250.00
8	Haul Away, cubic ft	486700	\$1.00	\$486,700.00	\$2.00	\$973,400.00	\$1,460,100.00
9	Asphalt Replacement, sq ft	57500	\$5.50	\$316,250.00	\$5.00	\$287,500.00	\$603,750.00
10	Sidewalk/Curb Replacement, ft	2160	\$100.00	\$216,000.00	\$40.00	\$86,400.00	\$302,400.00
11	Landscape Restoration, sq ft	7000	\$2.00	\$14,000.00	\$3.00	\$21,000.00	\$35,000.00
12	Utility Relocation, ft	695	\$100.00	\$69,500.00	\$100.00	\$69,500.00	\$139,000.00
13	Steel plating, days	92	\$480.00	\$44,160.00	\$0.00	\$0.00	\$44,160.00
14	Traffic Control, days	97	\$1,800.00	\$174,600.00	\$0.00	\$0.00	\$174,600.00
<b>TRENCHLESS INSTALLATION (JACK AND BORE)</b>							
15	Jack and Bore, Per ft	800	\$575.00	\$460,000.00	\$575.00	\$460,000.00	\$920,000.00
16	Mobilization / Demobilization, lot	1	\$0.00	\$0.00	\$75,000.00	\$75,000.00	\$75,000.00
17	Bore Spacer, each	160	\$540.00	\$86,400.00	\$100.00	\$16,000.00	\$102,400.00
18	Bore Grout, cubic ft	15800	\$3.50	\$55,300.00	\$2.00	\$31,600.00	\$86,900.00
19	Haul Away jack and bore, cubic ft	10100	\$1.00	\$10,100.00	\$2.00	\$20,200.00	\$30,300.00
20	Excavation Pit Soil Removal, Replacement and Compaction, cubic ft	25688	\$1.00	\$25,688.00	\$2.00	\$51,376.00	\$77,064.00
21	Asphalt Replacement, sq ft	1036	\$5.50	\$5,698.00	\$5.00	\$5,180.00	\$10,878.00
22	Shoring, per sq ft	2470	\$15.00	\$37,050.00	\$50.00	\$123,500.00	\$160,550.00
23	Traffic Control, days	20	\$1,800.00	\$36,000.00	\$0.00	\$0.00	\$36,000.00
24	Steel plating, days	20	\$480.00	\$9,600.00	\$0.00	\$0.00	\$9,600.00
<b>CABLE AND ACCESSORIES</b>							
25	XLPE Cable, per ft	55200	\$120.00	\$6,624,000.00	\$0.00	\$0.00	\$6,624,000.00
26	Spare XLPE Cable on reel, per ft	0	\$120.00	\$0.00	\$0.00	\$0.00	\$0.00
27	Terminators, each	0	\$7,200.00	\$0.00	\$9,000.00	\$0.00	\$0.00
28	Spare Terminators, each	0	\$7,200.00	\$0.00	\$0.00	\$0.00	\$0.00
29	Arresters, each	0	\$2,500.00	\$0.00	\$2,000.00	\$0.00	\$0.00
30	Spare Arrester, each	0	\$2,500.00	\$0.00	\$0.00	\$0.00	\$0.00
31	Splices, each	30	\$3,600.00	\$108,000.00	\$13,500.00	\$405,000.00	\$513,000.00
32	Racking for Vaults, each	10	\$40,000.00	\$400,000.00	\$0.00	\$0.00	\$400,000.00
33	Grounding System for Vault, each	10	\$4,000.00	\$40,000.00	\$3,000.00	\$30,000.00	\$70,000.00
34	Grounding System for Structure, each	0	\$3,500.00	\$0.00	\$1,500.00	\$0.00	\$0.00
35	Cable Clamps, each	180	\$100.00	\$18,000.00	\$150.00	\$27,000.00	\$45,000.00
36	Continuity Conductors, per ft	18400	\$5.96	\$109,664.00	\$0.00	\$0.00	\$109,664.00
37	Cable pulling, grounding, days	107.5	\$0.00	\$0.00	\$9,000.00	\$967,500.00	\$967,500.00
38	Jacket integrity test, per section	0	\$0.00	\$0.00	\$2,000.00	\$0.00	\$0.00
39	Discharge/Withstand Test, lot	0	\$0.00	\$0.00	\$120,000.00	\$0.00	\$0.00
<b>FIBER OPTIC</b>							
40	Fiber Optic Cable, per ft	10000	\$1.50	\$15,000.00	\$0.00	\$0.00	\$15,000.00
41	Hand Vaults for Fiber, each	5	\$700.00	\$3,500.00	\$1,000.00	\$5,000.00	\$8,500.00
42	Excavation for Hand Vaults & Haul away, cubic ft	350	\$1.00	\$350.00	\$3.00	\$1,050.00	\$1,400.00
43	Sidewalk/Curb Replacement, ft	50	\$100.00	\$5,000.00	\$40.00	\$2,000.00	\$7,000.00
44	Fiber Optic Cable splices, each	10	\$1,000.00	\$10,000.00	\$4,000.00	\$40,000.00	\$50,000.00
45	Temp. Sensing Fiber, ft	10000	\$1.50	\$15,000.00	\$0.00	\$0.00	\$15,000.00
46	Temp. Sensing Fiber System, lot	0	\$115,000.00	\$0.00	\$100,000.00	\$0.00	\$0.00
<b>TERMINATION (RISER STRUCTURES)</b>							
47	Structure, each	0	\$90,000.00	\$0.00	\$50,000.00	\$0.00	\$0.00
48	Foundation, each	0	\$35,000.00	\$0.00	\$0.00	\$0.00	\$0.00
<b>ENGINEERING/ MANAGEMENT/ MISC.</b>							
49	Engineering, lot	0	\$0.00	\$0.00	\$1,200,000.00	\$0.00	\$0.00
50	Geotechnical Including Thermal, per bore	9	\$0.00	\$0.00	\$4,600.00	\$41,400.00	\$41,400.00
51	Underground Utility Survey, lot	0	\$0.00	\$0.00	\$700,000.00	\$0.00	\$0.00
52	Construction Management, lot	0	\$0.00	\$0.00	\$625,000.00	\$0.00	\$0.00
53	Mobilization / Demobilization, lot	0	\$0.00	\$0.00	\$450,000.00	\$0.00	\$0.00
54	Permitting	0	\$0.00	\$0.00	\$0.00	\$0.00	\$0.00
55	Environmental Compliance & Monitoring	0	\$0.00	\$0.00	\$0.00	\$0.00	\$0.00
<b>SUMMARY</b>							
	Sales Tax (7.8%)			\$997,901.19			
	Summary of Cost			\$13,791,506.19		\$6,404,176.00	\$20,195,682.19
	Summary of Cost with Contingancy (20%)			\$16,549,807.43		\$7,685,011.20	\$24,234,818.63
<b>NOTES</b>							

- 1 Section Length is assumed to be 1.74 miles (9190 ft)
- 2 23 water pipe crossing
- 3 15 sewer pipe crossing

Section 5 - 6th to Speedway

ITEM	DESCRIPTION	QUANTITY	MATERIAL UNIT PRICE (\$/UNIT)	TOTAL MATERIAL COST (\$)	LABOR UNIT PRICE (\$ UNIT)	TOTAL LABOR COST (\$)	TOTAL OVERALL COST (\$)
<b>EARTHWORK AND DUCT BANK INSTALLATION</b>							
1	8 inch PVC Couduit, Per ft	30000	\$8.25	\$247,500.00	\$0.00	\$0.00	\$247,500.00
2	3 inch PVC Couduit, Per ft	21000	\$1.50	\$31,500.00	\$0.00	\$0.00	\$31,500.00
3	Conduit Duct Spacers, Each	1000	\$40.00	\$40,000.00	\$15.00	\$15,000.00	\$55,000.00
4	Man Vault, Each	4	\$45,000.00	\$180,000.00	\$25,000.00	\$100,000.00	\$280,000.00
5	Duct Installation, Per ft	3000	\$100.00	\$300,000.00	\$175.00	\$525,000.00	\$825,000.00
6	Additional Excavation due to UG Crossing, cubic foot	52800	\$2.00	\$105,600.00	\$2.00	\$105,600.00	\$211,200.00
7	Thermal Backfill, cubic foot	86900	\$3.50	\$304,150.00	\$2.00	\$173,800.00	\$477,950.00
8	Haul Away, cubic ft	165600	\$1.00	\$165,600.00	\$2.00	\$331,200.00	\$496,800.00
9	Asphalt Replacement, sq ft	16100	\$5.50	\$88,550.00	\$5.00	\$80,500.00	\$169,050.00
10	Sidewalk/Curb Replacement, ft	2387	\$100.00	\$238,700.00	\$40.00	\$95,480.00	\$334,180.00
11	Landscape Restoration, sq ft	9600	\$2.00	\$19,200.00	\$3.00	\$28,800.00	\$48,000.00
12	Utility Relocation, ft	50	\$100.00	\$5,000.00	\$100.00	\$5,000.00	\$10,000.00
13	Steel plating, days	30	\$480.00	\$14,400.00	\$0.00	\$0.00	\$14,400.00
14	Traffic Control, days	35	\$1,800.00	\$63,000.00	\$0.00	\$0.00	\$63,000.00
<b>TRENCHLESS INSTALLATION (JACK AND BORE)</b>							
15	Jack and Bore, Per ft	0	\$575.00	\$0.00	\$575.00	\$0.00	\$0.00
16	Mobilization / Demobilization, lot	0	\$0.00	\$0.00	\$75,000.00	\$0.00	\$0.00
17	Bore Spacer, each	0	\$540.00	\$0.00	\$100.00	\$0.00	\$0.00
18	Bore Grout, cubic ft	0	\$3.50	\$0.00	\$2.00	\$0.00	\$0.00
19	Haul Away jack and bore, cubic ft	0	\$1.00	\$0.00	\$2.00	\$0.00	\$0.00
20	Excavation Pit Soil Removal, Replacement and Compaction, cubic ft	0	\$1.00	\$0.00	\$2.00	\$0.00	\$0.00
21	Asphalt Replacement, sq ft	0	\$5.50	\$0.00	\$5.00	\$0.00	\$0.00
22	Shoring, per sq ft	0	\$15.00	\$0.00	\$50.00	\$0.00	\$0.00
23	Traffic Control, days	0	\$1,800.00	\$0.00	\$0.00	\$0.00	\$0.00
24	Steel plating, days	0	\$480.00	\$0.00	\$0.00	\$0.00	\$0.00
<b>CABLE AND ACCESSORIES</b>							
25	XLPE Cable, per ft	18000	\$120.00	\$2,160,000.00	\$0.00	\$0.00	\$2,160,000.00
26	Spare XLPE Cable on reel, per ft	0	\$120.00	\$0.00	\$0.00	\$0.00	\$0.00
27	Terminators, each	0	\$7,200.00	\$0.00	\$9,000.00	\$0.00	\$0.00
28	Spare Terminators, each	0	\$7,200.00	\$0.00	\$0.00	\$0.00	\$0.00
29	Arresters, each	0	\$2,500.00	\$0.00	\$2,000.00	\$0.00	\$0.00
30	Spare Arrester, each	0	\$2,500.00	\$0.00	\$0.00	\$0.00	\$0.00
31	Splices, each	12	\$3,600.00	\$43,200.00	\$9,000.00	\$108,000.00	\$151,200.00
32	Racking for Vaults, each	4	\$40,000.00	\$160,000.00	\$0.00	\$0.00	\$160,000.00
33	Grounding System for Vault, each	4	\$4,000.00	\$16,000.00	\$3,000.00	\$12,000.00	\$28,000.00
34	Grounding System for Structure, each	0	\$3,500.00	\$0.00	\$1,500.00	\$0.00	\$0.00
35	Cable Clamps, each	72	\$100.00	\$7,200.00	\$150.00	\$10,800.00	\$18,000.00
36	Continuity Conductors, per ft	5996	\$5.96	\$35,736.16	\$0.00	\$0.00	\$35,736.16
37	Cable pulling, grounding, days	43	\$0.00	\$0.00	\$9,000.00	\$387,000.00	\$387,000.00
38	Jacket integrity test, per section	0	\$0.00	\$0.00	\$2,000.00	\$0.00	\$0.00
39	Discharge/Withstand Test, lot	0	\$0.00	\$0.00	\$120,000.00	\$0.00	\$0.00
<b>FIBER OPTIC</b>							
40	Fiber Optic Cable, per ft	4000	\$1.50	\$6,000.00	\$0.00	\$0.00	\$6,000.00
41	Hand Vaults for Fiber, each	2	\$700.00	\$1,400.00	\$1,000.00	\$2,000.00	\$3,400.00
42	Excavation for Hand Vaults & Haul away, cubic ft	140	\$1.00	\$140.00	\$3.00	\$420.00	\$560.00
43	Sidewalk/Curb Replacement, ft	20	\$100.00	\$2,000.00	\$40.00	\$800.00	\$2,800.00
44	Fiber Optic Cable splices, each	4	\$1,000.00	\$4,000.00	\$4,000.00	\$16,000.00	\$20,000.00
45	Temp. Sensing Fiber, ft	4000	\$1.50	\$6,000.00	\$0.00	\$0.00	\$6,000.00
46	Temp. Sensing Fiber System, lot	0	\$115,000.00	\$0.00	\$100,000.00	\$0.00	\$0.00
<b>TERMINATION (RISER STRUCTURES)</b>							
47	Structure, each	0	\$90,000.00	\$0.00	\$50,000.00	\$0.00	\$0.00
48	Foundation, each	0	\$35,000.00	\$0.00	\$0.00	\$0.00	\$0.00
<b>ENGINEERING/ MANAGEMENT/ MISC.</b>							
49	Engineering, lot	0	\$0.00	\$0.00	\$1,200,000.00	\$0.00	\$0.00
50	Geotechnical Including Thermal, per bore	2	\$0.00	\$0.00	\$4,600.00	\$9,200.00	\$9,200.00
51	Underground Utility Survey, lot	0	\$0.00	\$0.00	\$700,000.00	\$0.00	\$0.00
52	Construction Management, lot	0	\$0.00	\$0.00	\$625,000.00	\$0.00	\$0.00
53	Mobilization / Demobilization, lot	0	\$0.00	\$0.00	\$450,000.00	\$0.00	\$0.00
54	Permitting	0	\$0.00	\$0.00	\$0.00	\$0.00	\$0.00
55	Environmental Compliance & Monitoring	0	\$0.00	\$0.00	\$0.00	\$0.00	\$0.00
<b>SUMMARY</b>							
	Sales Tax (7.8%)			\$331,100.34			
	Summary of Cost			\$4,575,976.50		\$2,006,600.00	\$6,582,576.50
	Summary of Cost with Contingancy (20%)			\$5,491,171.80		\$2,407,920.00	\$7,899,091.80
<b>NOTES</b>							

- 1 Section Length is assumed to be 0.56 miles (2998 ft)
- 2 9 water pipe crossing
- 3 6 sewer pipe crossing

Section 4 - Broadway to 6th

ITEM	DESCRIPTION	QUANTITY	MATERIAL UNIT PRICE (\$/UNIT)	TOTAL MATERIAL COST (\$)	LABOR UNIT PRICE (\$ UNIT)	TOTAL LABOR COST (\$)	TOTAL OVERALL COST (\$)
<b>EARTHWORK AND DUCT BANK INSTALLATION</b>							
1	8 inch PVC Couduit, Per ft	23300	\$8.25	\$192,225.00	\$0.00	\$0.00	\$192,225.00
2	3 inch PVC Couduit, Per ft	16400	\$1.50	\$24,600.00	\$0.00	\$0.00	\$24,600.00
3	Conduit Duct Spacers, Each	780	\$40.00	\$31,200.00	\$15.00	\$11,700.00	\$42,900.00
4	Man Vault, Each	2	\$45,000.00	\$90,000.00	\$25,000.00	\$50,000.00	\$140,000.00
5	Duct Installation, Per ft	2400	\$100.00	\$240,000.00	\$175.00	\$420,000.00	\$660,000.00
6	Additional Excavation due to UG Crossing, cubic foot	42240	\$2.00	\$84,480.00	\$2.00	\$84,480.00	\$168,960.00
7	Thermal Backfill, cubic foot	57300	\$3.50	\$200,550.00	\$2.00	\$114,600.00	\$315,150.00
8	Haul Away, cubic ft	118500	\$1.00	\$118,500.00	\$2.00	\$237,000.00	\$355,500.00
9	Asphalt Replacement, sq ft	10900	\$5.50	\$59,950.00	\$5.00	\$54,500.00	\$114,450.00
10	Sidewalk/Curb Replacement, ft	1940	\$100.00	\$194,000.00	\$40.00	\$77,600.00	\$271,600.00
11	Landscape Restoration, sq ft	3650	\$2.00	\$7,300.00	\$3.00	\$10,950.00	\$18,250.00
12	Utility Relocation, ft	120	\$100.00	\$12,000.00	\$100.00	\$12,000.00	\$24,000.00
13	Steel plating, days	24	\$480.00	\$11,520.00	\$0.00	\$0.00	\$11,520.00
14	Traffic Control, days	29	\$1,800.00	\$52,200.00	\$0.00	\$0.00	\$52,200.00
<b>TRENCHLESS INSTALLATION (JACK AND BORE)</b>							
15	Jack and Bore, Per ft	0	\$575.00	\$0.00	\$575.00	\$0.00	\$0.00
16	Mobilization / Demobilization, lot	0	\$0.00	\$0.00	\$75,000.00	\$0.00	\$0.00
17	Bore Spacer, each	0	\$540.00	\$0.00	\$100.00	\$0.00	\$0.00
18	Bore Grout, cubic ft	0	\$3.50	\$0.00	\$2.00	\$0.00	\$0.00
19	Haul Away jack and bore, cubic ft	0	\$1.00	\$0.00	\$2.00	\$0.00	\$0.00
20	Excavation Pit Soil Removal, Replacement and Compaction, cubic ft	0	\$1.00	\$0.00	\$2.00	\$0.00	\$0.00
21	Asphalt Replacement, sq ft	0	\$5.50	\$0.00	\$5.00	\$0.00	\$0.00
22	Shoring, per sq ft	0	\$15.00	\$0.00	\$50.00	\$0.00	\$0.00
23	Traffic Control, days	0	\$1,800.00	\$0.00	\$0.00	\$0.00	\$0.00
24	Steel plating, days	0	\$480.00	\$0.00	\$0.00	\$0.00	\$0.00
<b>CABLE AND ACCESSORIES</b>							
25	XLPE Cable, per ft	14000	\$120.00	\$1,680,000.00	\$0.00	\$0.00	\$1,680,000.00
26	Spare XLPE Cable on reel, per ft	0	\$120.00	\$0.00	\$0.00	\$0.00	\$0.00
27	Terminators, each	0	\$7,200.00	\$0.00	\$9,000.00	\$0.00	\$0.00
28	Spare Terminators, each	0	\$7,200.00	\$0.00	\$0.00	\$0.00	\$0.00
29	Arresters, each	0	\$2,500.00	\$0.00	\$2,000.00	\$0.00	\$0.00
30	Spare Arrester, each	0	\$2,500.00	\$0.00	\$0.00	\$0.00	\$0.00
31	Splices, each	6	\$3,600.00	\$21,600.00	\$9,000.00	\$54,000.00	\$75,600.00
32	Racking for Vaults, each	2	\$40,000.00	\$80,000.00	\$0.00	\$0.00	\$80,000.00
33	Grounding System for Vault, each	2	\$4,000.00	\$8,000.00	\$3,000.00	\$6,000.00	\$14,000.00
34	Grounding System for Structure, each	0	\$3,500.00	\$0.00	\$1,500.00	\$0.00	\$0.00
35	Cable Clamps, each	36	\$100.00	\$3,600.00	\$150.00	\$5,400.00	\$9,000.00
36	Continuity Conductors, per ft	4660	\$5.96	\$27,773.60	\$0.00	\$0.00	\$27,773.60
37	Cable pulling, grounding, days	21.5	\$0.00	\$0.00	\$9,000.00	\$193,500.00	\$193,500.00
38	Jacket integrity test, per section	0	\$0.00	\$0.00	\$2,000.00	\$0.00	\$0.00
39	Discharge/Withstand Test, lot	0	\$0.00	\$0.00	\$120,000.00	\$0.00	\$0.00
<b>FIBER OPTIC</b>							
40	Fiber Optic Cable, per ft	3000	\$1.50	\$4,500.00	\$0.00	\$0.00	\$4,500.00
41	Hand Vaults for Fiber, each	2	\$700.00	\$1,400.00	\$1,000.00	\$2,000.00	\$3,400.00
42	Excavation for Hand Vaults & Haul away, cubic ft	140	\$1.00	\$140.00	\$3.00	\$420.00	\$560.00
43	Sidewalk/Curb Replacement, ft	20	\$100.00	\$2,000.00	\$40.00	\$800.00	\$2,800.00
44	Fiber Optic Cable splices, each	4	\$1,000.00	\$4,000.00	\$4,000.00	\$16,000.00	\$20,000.00
45	Temp. Sensing Fiber, ft	3000	\$1.50	\$4,500.00	\$0.00	\$0.00	\$4,500.00
46	Temp. Sensing Fiber System, lot	0	\$115,000.00	\$0.00	\$100,000.00	\$0.00	\$0.00
<b>TERMINATION (RISER STRUCTURES)</b>							
47	Structure, each	0	\$90,000.00	\$0.00	\$50,000.00	\$0.00	\$0.00
48	Foundation, each	0	\$35,000.00	\$0.00	\$0.00	\$0.00	\$0.00
<b>ENGINEERING/ MANAGEMENT/ MISC.</b>							
49	Engineering, lot	0	\$0.00	\$0.00	\$1,200,000.00	\$0.00	\$0.00
50	Geotechnical Including Thermal, per bore	2	\$0.00	\$0.00	\$4,600.00	\$9,200.00	\$9,200.00
51	Underground Utility Survey, lot	0	\$0.00	\$0.00	\$700,000.00	\$0.00	\$0.00
52	Construction Management, lot	0	\$0.00	\$0.00	\$625,000.00	\$0.00	\$0.00
53	Mobilization / Demobilization, lot	0	\$0.00	\$0.00	\$450,000.00	\$0.00	\$0.00
54	Permitting	0	\$0.00	\$0.00	\$0.00	\$0.00	\$0.00
55	Environmental Compliance & Monitoring	0	\$0.00	\$0.00	\$0.00	\$0.00	\$0.00
<b>SUMMARY</b>							
	Sales Tax (7.8%)			\$246,171.01			
	Summary of Cost			\$3,402,209.61		\$1,360,150.00	\$4,762,359.61
	Summary of Cost with Contingancy (20%)			\$4,082,651.53		\$1,632,180.00	\$5,714,831.53
<b>NOTES</b>							

- 1 Section Length is assumed to be 0.44 miles (2,330 ft)
- 2 6water pipe crossing
- 3 6 sewer pipe crossing



Section 6 Speedway to UA North Sub

ITEM	DESCRIPTION	QUANTITY	MATERIAL UNIT PRICE (\$/UNIT)	TOTAL MATERIAL COST (\$)	LABOR UNIT PRICE (\$ UNIT)	TOTAL LABOR COST (\$)	TOTAL OVERALL COST (\$)
<b>EARTHWORK AND DUCT BANK INSTALLATION</b>							
1	8 inch PVC Conduit, Per ft	42500	\$8.25	\$350,625.00	\$0.00	\$0.00	\$350,625.00
2	3 inch PVC Conduit, Per ft	29800	\$1.50	\$44,700.00	\$0.00	\$0.00	\$44,700.00
3	Conduit Duct Spacers, Each	1420	\$40.00	\$56,800.00	\$15.00	\$21,300.00	\$78,100.00
4	Man Vault, Each	4	\$45,000.00	\$180,000.00	\$25,000.00	\$100,000.00	\$280,000.00
5	Duct Installation, Per ft	4300	\$100.00	\$430,000.00	\$175.00	\$752,500.00	\$1,182,500.00
6	Additional Excavation due to UG Crossing, cubic foot	52800	\$2.00	\$105,600.00	\$2.00	\$105,600.00	\$211,200.00
7	Thermal Backfill, cubic foot	107700	\$3.50	\$376,950.00	\$2.00	\$215,400.00	\$592,350.00
8	Haul Away, cubic ft	219200	\$1.00	\$219,200.00	\$2.00	\$438,400.00	\$657,600.00
9	Asphalt Replacement, sq ft	30700	\$5.50	\$168,850.00	\$5.00	\$153,500.00	\$322,350.00
10	Sidewalk/Curb Replacement, ft	1980	\$140.00	\$277,200.00	\$0.00	\$0.00	\$277,200.00
11	Landscape Restoration, sq ft	2000	\$2.00	\$4,000.00	\$3.00	\$6,000.00	\$10,000.00
12	Utility Relocation, ft	215	\$100.00	\$21,500.00	\$100.00	\$21,500.00	\$43,000.00
13	Steel plating, days	43	\$480.00	\$20,640.00	\$0.00	\$0.00	\$20,640.00
14	Traffic Control, days	48	\$1,800.00	\$86,400.00	\$0.00	\$0.00	\$86,400.00
<b>TRENCHLESS INSTALLATION (JACK AND BORE)</b>							
15	Jack and Bore, Per ft	0	\$575.00	\$0.00	\$575.00	\$0.00	\$0.00
16	Mobilization / Demobilization, lot	0	\$0.00	\$0.00	\$75,000.00	\$0.00	\$0.00
17	Bore Spacer, each	0	\$540.00	\$0.00	\$100.00	\$0.00	\$0.00
18	Bore Grout, cubic ft	0	\$3.50	\$0.00	\$2.00	\$0.00	\$0.00
19	Haul Away jack and bore, cubic ft	0	\$1.00	\$0.00	\$2.00	\$0.00	\$0.00
20	Excavation Pit Soil Removal, Replacement and Compaction, cubic ft	0	\$1.00	\$0.00	\$2.00	\$0.00	\$0.00
21	Asphalt Replacement, sq ft	0	\$5.50	\$0.00	\$5.00	\$0.00	\$0.00
22	Shoring, per sq ft	0	\$15.00	\$0.00	\$50.00	\$0.00	\$0.00
23	Traffic Control, days	0	\$1,800.00	\$0.00	\$0.00	\$0.00	\$0.00
24	Steel plating, days	0	\$480.00	\$0.00	\$0.00	\$0.00	\$0.00
<b>CABLE AND ACCESSORIES</b>							
25	XLPE Cable, per ft	25500	\$120.00	\$3,060,000.00	\$0.00	\$0.00	\$3,060,000.00
26	Spare XLPE Cable on reel, per ft	0	\$120.00	\$0.00	\$0.00	\$0.00	\$0.00
27	Terminators, each	0	\$7,200.00	\$0.00	\$9,000.00	\$0.00	\$0.00
28	Spare Terminators, each	0	\$7,200.00	\$0.00	\$0.00	\$0.00	\$0.00
29	Arresters, each	0	\$2,500.00	\$0.00	\$2,000.00	\$0.00	\$0.00
30	Spare Arrester, each	0	\$2,500.00	\$0.00	\$0.00	\$0.00	\$0.00
31	Splices, each	12	\$3,600.00	\$43,200.00	\$9,000.00	\$108,000.00	\$151,200.00
32	Racking for Vaults, each	4	\$40,000.00	\$160,000.00	\$0.00	\$0.00	\$160,000.00
33	Grounding System for Vault, each	4	\$4,000.00	\$16,000.00	\$3,000.00	\$12,000.00	\$28,000.00
34	Grounding System for Structure, each	0	\$3,500.00	\$0.00	\$1,500.00	\$0.00	\$0.00
35	Cable Clamps, each	72	\$100.00	\$7,200.00	\$150.00	\$10,800.00	\$18,000.00
36	Continuity Conductors, per ft	8494	\$5.96	\$50,624.24	\$0.00	\$0.00	\$50,624.24
37	Cable pulling, grounding, days	43	\$0.00	\$0.00	\$9,000.00	\$387,000.00	\$387,000.00
38	Jacket integrity test, per section	0	\$0.00	\$0.00	\$2,000.00	\$0.00	\$0.00
39	Discharge/Withstand Test, lot	0	\$0.00	\$0.00	\$120,000.00	\$0.00	\$0.00
<b>FIBER OPTIC</b>							
40	Fiber Optic Cable, per ft	5000	\$1.50	\$7,500.00	\$0.00	\$0.00	\$7,500.00
41	Hand Vaults for Fiber, each	2	\$700.00	\$1,400.00	\$1,000.00	\$2,000.00	\$3,400.00
42	Excavation for Hand Vaults & Haul away, cubic ft	140	\$1.00	\$140.00	\$3.00	\$420.00	\$560.00
43	Sidewalk/Curb Replacement, ft	20	\$100.00	\$2,000.00	\$40.00	\$800.00	\$2,800.00
44	Fiber Optic Cable splices, each	4	\$1,000.00	\$4,000.00	\$4,000.00	\$16,000.00	\$20,000.00
45	Temp. Sensing Fiber, ft	5000	\$1.50	\$7,500.00	\$0.00	\$0.00	\$7,500.00
46	Temp. Sensing Fiber System, lot	0	\$115,000.00	\$0.00	\$100,000.00	\$0.00	\$0.00
<b>TERMINATION (RISER STRUCTURES)</b>							
47	Structure, each	0	\$90,000.00	\$0.00	\$50,000.00	\$0.00	\$0.00
48	Foundation, each	0	\$35,000.00	\$0.00	\$0.00	\$0.00	\$0.00
<b>ENGINEERING/ MANAGEMENT/ MISC.</b>							
49	Engineering, lot	0	\$0.00	\$0.00	\$1,200,000.00	\$0.00	\$0.00
50	Geotechnical Including Thermal, per bore	3	\$0.00	\$0.00	\$4,600.00	\$13,800.00	\$13,800.00
51	Underground Utility Survey, lot	0	\$0.00	\$0.00	\$700,000.00	\$0.00	\$0.00
52	Construction Management, lot	0	\$0.00	\$0.00	\$625,000.00	\$0.00	\$0.00
53	Mobilization / Demobilization, lot	0	\$0.00	\$0.00	\$450,000.00	\$0.00	\$0.00
54	Permitting	0	\$0.00	\$0.00	\$0.00	\$0.00	\$0.00
55	Environmental Compliance & Monitoring	0	\$0.00	\$0.00	\$0.00	\$0.00	\$0.00
<b>SUMMARY</b>							
	Sales Tax (7.8%)			\$444,758.28			
	Summary of Cost			\$6,146,787.52		\$2,365,020.00	\$8,511,807.52
	Summary of Cost with Contingancy (20%)			\$7,376,145.02		\$2,838,024.00	\$10,214,169.02
<b>NOTES</b>							

- 1 Section Length is assumed to be 0.80 miles (4,247 ft)
- 2 17 water pipe crossing
- 3 4 sewer pipe crossing

Section 7 - UA North Sub to Grant

ITEM	DESCRIPTION	QUANTITY	MATERIAL UNIT PRICE (\$/UNIT)	TOTAL MATERIAL COST (\$)	LABOR UNIT PRICE (\$ UNIT)	TOTAL LABOR COST (\$)	TOTAL OVERALL COST (\$)
<b>EARTHWORK AND DUCT BANK INSTALLATION</b>							
1	8 inch PVC Conduit, Per ft	44100	\$8.25	\$363,825.00	\$0.00	\$0.00	\$363,825.00
2	3 inch PVC Conduit, Per ft	30900	\$1.50	\$46,350.00	\$0.00	\$0.00	\$46,350.00
3	Conduit Duct Spacers, Each	1470	\$40.00	\$58,800.00	\$15.00	\$22,050.00	\$80,850.00
4	Man Vault, Each	4	\$45,000.00	\$180,000.00	\$25,000.00	\$100,000.00	\$280,000.00
5	Duct Installation, Per ft	4500	\$100.00	\$450,000.00	\$175.00	\$787,500.00	\$1,237,500.00
6	Additional Excavation due to UG Crossing, cubic foot	52800	\$2.00	\$105,600.00	\$2.00	\$105,600.00	\$211,200.00
7	Thermal Backfill, cubic foot	110400	\$3.50	\$386,400.00	\$2.00	\$220,800.00	\$607,200.00
8	Haul Away, cubic ft	226100	\$1.00	\$226,100.00	\$2.00	\$452,200.00	\$678,300.00
9	Asphalt Replacement, sq ft	32200	\$5.50	\$177,100.00	\$5.00	\$161,000.00	\$338,100.00
10	Sidewalk/Curb Replacement, ft	2260	\$100.00	\$226,000.00	\$40.00	\$90,400.00	\$316,400.00
11	Landscape Restoration, sq ft	500	\$2.00	\$1,000.00	\$3.00	\$1,500.00	\$2,500.00
12	Utility Relocation, ft	700	\$100.00	\$70,000.00	\$100.00	\$70,000.00	\$140,000.00
13	Steel plating, days	45	\$480.00	\$21,600.00	\$0.00	\$0.00	\$21,600.00
14	Traffic Control, days	50	\$1,800.00	\$90,000.00	\$0.00	\$0.00	\$90,000.00
<b>TRENCHLESS INSTALLATION (JACK AND BORE)</b>							
15	Jack and Bore, Per ft	0	\$575.00	\$0.00	\$575.00	\$0.00	\$0.00
16	Mobilization / Demobilization, lot	0	\$0.00	\$0.00	\$75,000.00	\$0.00	\$0.00
17	Bore Spacer, each	0	\$540.00	\$0.00	\$100.00	\$0.00	\$0.00
18	Bore Grout, cubic ft	0	\$3.50	\$0.00	\$2.00	\$0.00	\$0.00
19	Haul Away jack and bore, cubic ft	0	\$1.00	\$0.00	\$2.00	\$0.00	\$0.00
20	Excavation Pit Soil Removal, Replacement and Compaction, cubic ft	0	\$1.00	\$0.00	\$2.00	\$0.00	\$0.00
21	Asphalt Replacement, sq ft	0	\$5.50	\$0.00	\$5.00	\$0.00	\$0.00
22	Shoring, per sq ft	0	\$15.00	\$0.00	\$50.00	\$0.00	\$0.00
23	Traffic Control, days	0	\$1,800.00	\$0.00	\$0.00	\$0.00	\$0.00
24	Steel plating, days	0	\$480.00	\$0.00	\$0.00	\$0.00	\$0.00
<b>CABLE AND ACCESSORIES</b>							
25	XLPE Cable, per ft	26500	\$120.00	\$3,180,000.00	\$0.00	\$0.00	\$3,180,000.00
26	Spare XLPE Cable on reel, per ft	0	\$120.00	\$0.00	\$0.00	\$0.00	\$0.00
27	Terminators, each	6	\$7,200.00	\$43,200.00	\$20,000.00	\$120,000.00	\$163,200.00
28	Spare Terminators, each	0	\$7,200.00	\$0.00	\$0.00	\$0.00	\$0.00
29	Arresters, each	6	\$2,500.00	\$15,000.00	\$2,000.00	\$12,000.00	\$27,000.00
30	Spare Arrester, each	0	\$2,500.00	\$0.00	\$0.00	\$0.00	\$0.00
31	Splices, each	12	\$3,600.00	\$43,200.00	\$9,000.00	\$108,000.00	\$151,200.00
32	Racking for Vaults, each	4	\$40,000.00	\$160,000.00	\$0.00	\$0.00	\$160,000.00
33	Grounding System for Vault, each	4	\$4,000.00	\$16,000.00	\$3,000.00	\$12,000.00	\$28,000.00
34	Grounding System for Structure, each	0	\$3,500.00	\$0.00	\$1,500.00	\$0.00	\$0.00
35	Cable Clamps, each	168	\$100.00	\$16,800.00	\$150.00	\$25,200.00	\$42,000.00
36	Continuity Conductors, per ft	8814	\$5.96	\$52,531.44	\$0.00	\$0.00	\$52,531.44
37	Cable pulling, grounding, days	43	\$0.00	\$0.00	\$9,000.00	\$387,000.00	\$387,000.00
38	Jacket integrity test, per section	0	\$0.00	\$0.00	\$2,000.00	\$0.00	\$0.00
39	Discharge/Withstand Test, lot	0	\$0.00	\$0.00	\$120,000.00	\$0.00	\$0.00
<b>FIBER OPTIC</b>							
40	Fiber Optic Cable, per ft	5000	\$1.50	\$7,500.00	\$0.00	\$0.00	\$7,500.00
41	Hand Vaults for Fiber, each	2	\$700.00	\$1,400.00	\$1,000.00	\$2,000.00	\$3,400.00
42	Excavation for Hand Vaults & Haul away, cubic ft	140	\$1.00	\$140.00	\$3.00	\$420.00	\$560.00
43	Sidewalk/Curb Replacement, ft	20	\$100.00	\$2,000.00	\$40.00	\$800.00	\$2,800.00
44	Fiber Optic Cable splices, each	4	\$1,000.00	\$4,000.00	\$4,000.00	\$16,000.00	\$20,000.00
45	Temp. Sensing Fiber, ft	5000	\$1.50	\$7,500.00	\$0.00	\$0.00	\$7,500.00
46	Temp. Sensing Fiber System, lot	0	\$115,000.00	\$0.00	\$100,000.00	\$0.00	\$0.00
<b>TERMINATION (RISER STRUCTURES)</b>							
47	Structure, each	1	\$90,000.00	\$90,000.00	\$50,000.00	\$50,000.00	\$140,000.00
48	Foundation, each	1	\$35,000.00	\$35,000.00	\$0.00	\$0.00	\$35,000.00
<b>ENGINEERING/ MANAGEMENT/ MISC.</b>							
49	Engineering, lot	0	\$0.00	\$0.00	\$1,200,000.00	\$0.00	\$0.00
50	Geotechnical Including Thermal, per bore	3	\$0.00	\$0.00	\$4,600.00	\$13,800.00	\$13,800.00
51	Underground Utility Survey, lot	0	\$0.00	\$0.00	\$700,000.00	\$0.00	\$0.00
52	Construction Management, lot	0	\$0.00	\$0.00	\$625,000.00	\$0.00	\$0.00
53	Mobilization / Demobilization, lot	0	\$0.00	\$0.00	\$450,000.00	\$0.00	\$0.00
54	Permitting	0	\$0.00	\$0.00	\$0.00	\$0.00	\$0.00
55	Environmental Compliance & Monitoring	0	\$0.00	\$0.00	\$0.00	\$0.00	\$0.00
<b>SUMMARY</b>							
	Sales Tax (7.8%)			\$474,009.62			
	Summary of Cost			\$6,551,056.06		\$2,758,270.00	\$9,309,326.06
	Summary of Cost with Contingancy (20%)			\$7,861,267.27		\$3,309,924.00	\$11,171,191.27
<b>NOTES</b>							

- 1 Section Length is assumed to be 0.84 miles (4407 ft)
- 2 5 water pipe crossing
- 3 3 sewer pipe crossing

Engineering and Commissioning

ITEM	DESCRIPTION	QUANTITY	MATERIAL UNIT PRICE (\$/UNIT)	TOTAL MATERIAL COST (\$)	LABOR UNIT PRICE (\$ UNIT)	TOTAL LABOR COST (\$)	TOTAL OVERALL COST (\$)
<b>EARTHWORK AND DUCT BANK INSTALLATION</b>							
1	8 inch PVC Conduit, Per ft	0	\$8.25	\$0.00	\$0.00	\$0.00	\$0.00
2	3 inch PVC Conduit, Per ft	0	\$1.75	\$0.00	\$0.00	\$0.00	\$0.00
3	Conduit Duct Spacers, Each	0	\$40.00	\$0.00	\$15.00	\$0.00	\$0.00
4	Man Vault, Each	0	\$45,000.00	\$0.00	\$25,000.00	\$0.00	\$0.00
5	Duct Installation, Per ft	0	\$0.00	\$0.00	\$275.00	\$0.00	\$0.00
6	Additional Excavation due to UG Crossing, cubic foot	0	\$2.00	\$0.00	\$2.00	\$0.00	\$0.00
7	Thermal Backfill, cubic foot	0	\$3.50	\$0.00	\$2.00	\$0.00	\$0.00
8	Haul Away, cubic ft	0	\$2.00	\$0.00	\$0.00	\$0.00	\$0.00
9	Asphalt Replacement, sq ft	0	\$5.50	\$0.00	\$5.00	\$0.00	\$0.00
10	Sidewalk/Curb Replacement, ft	0	\$140.00	\$0.00	\$0.00	\$0.00	\$0.00
11	Landscape Restoration, sq ft	0	\$4.00	\$0.00	\$0.00	\$0.00	\$0.00
12	Utility Relocation, each	0	\$100.00	\$0.00	\$100.00	\$0.00	\$0.00
13	Steel plating, days	0	\$480.00	\$0.00	\$0.00	\$0.00	\$0.00
14	Traffic Control, days	0	\$1,800.00	\$0.00	\$0.00	\$0.00	\$0.00
<b>TRENCHLESS INSTALLATION (JACK AND BORE)</b>							
15	Jack and Bore, Per ft	0	\$692.50	\$0.00	\$575.00	\$0.00	\$0.00
16	Mobilization / Demobilization, lot	0	\$0.00	\$0.00	\$75,000.00	\$0.00	\$0.00
17	Bore Spacer, each	0	\$275.00	\$0.00	\$100.00	\$0.00	\$0.00
18	Bore Grout, cubic ft	0	\$1.85	\$0.00	\$2.00	\$0.00	\$0.00
19	Haul Away jack and bore, cubic ft	0	\$2.00	\$0.00	\$2.00	\$0.00	\$0.00
20	Excavation Pit Soil Removal, Replacement and Compaction, cubic ft	0	\$1.25	\$0.00	\$2.00	\$0.00	\$0.00
21	Asphalt Replacement, sq ft	0	\$5.50	\$0.00	\$5.00	\$0.00	\$0.00
22	Shoring, per sq ft	0	\$13.00	\$0.00	\$50.00	\$0.00	\$0.00
23	Traffic Control, days	0	\$1,800.00	\$0.00	\$0.00	\$0.00	\$0.00
24	Steel plating, days	0	\$480.00	\$0.00	\$0.00	\$0.00	\$0.00
<b>CABLE AND ACCESSORIES</b>							
25	XLPE Cable, per ft	0	\$120.00	\$0.00	\$0.00	\$0.00	\$0.00
26	Spare XLPE Cable on reel, per ft	4200	\$120.00	\$504,000.00	\$0.00	\$0.00	\$504,000.00
27	Terminators, each	0	\$7,200.00	\$0.00	\$9,000.00	\$0.00	\$0.00
28	Spare Terminators, each	2	\$7,200.00	\$14,400.00	\$0.00	\$0.00	\$14,400.00
29	Arresters, each	0	\$2,500.00	\$0.00	\$2,000.00	\$0.00	\$0.00
30	Spare Arrester, each	2	\$2,500.00	\$5,000.00	\$0.00	\$0.00	\$5,000.00
31	Splices, each	0	\$3,600.00	\$0.00	\$9,000.00	\$0.00	\$0.00
32	Spare Splices, each	8	\$3,600.00	\$28,800.00	\$0.00	\$0.00	\$28,800.00
33	Grounding System for Vault, each	0	\$4,000.00	\$0.00	\$3,000.00	\$0.00	\$0.00
34	Grounding System for Structure, each	0	\$3,500.00	\$0.00	\$1,500.00	\$0.00	\$0.00
35	Cable Clamps, each	0	\$100.00	\$0.00	\$0.00	\$0.00	\$0.00
36	Continuity Conductors, per ft	0	\$3.50	\$0.00	\$0.00	\$0.00	\$0.00
37	Cable Installation, Splicing, grounding, days	0	\$0.00	\$0.00	\$9,000.00	\$0.00	\$0.00
38	Jacket integrity test, per section	128	\$0.00	\$0.00	\$2,000.00	\$256,000.00	\$256,000.00
39	Discharge/Withstand Test, lot	1	\$0.00	\$0.00	\$120,000.00	\$120,000.00	\$120,000.00
<b>FIBER OPTIC</b>							
40	Fiber Optic Cable, per ft	0	\$1.50	\$0.00	\$0.00	\$0.00	\$0.00
41	Hand Vaults for Fiber, each	0	\$700.00	\$0.00	\$0.00	\$0.00	\$0.00
42	Excavation for Hand Vaults & Haul away, cubic ft	0	\$2.00	\$0.00	\$14.50	\$0.00	\$0.00
43	Sidewalk/Curb Replacement, ft	0	\$140.00	\$0.00	\$0.00	\$0.00	\$0.00
44	Fiber Optic Cable splices, each	0	\$1,000.00	\$0.00	\$4,000.00	\$0.00	\$0.00
45	Temp. Sensing Fiber, ft	0	\$1.50	\$0.00	\$0.00	\$0.00	\$0.00
46	Temp. Sensing Fiber System, lot	1	\$215,000.00	\$215,000.00	\$0.00	\$0.00	\$215,000.00
<b>TERMINATION (RISER STRUCTURES)</b>							
47	Structure, each	0	\$90,000.00	\$0.00	\$50,000.00	\$0.00	\$0.00
48	Foundation, each	0	\$35,000.00	\$0.00	\$0.00	\$0.00	\$0.00
<b>ENGINEERING/ MANAGEMENT/ MISC.</b>							
49	Engineering, lot	1	\$0.00	\$0.00	\$1,200,000.00	\$1,200,000.00	\$1,200,000.00
50	Geotechnical Including Thermal, per bore	0	\$0.00	\$0.00	\$4,600.00	\$0.00	\$0.00
51	Underground Utility Survey, lot	1	\$0.00	\$0.00	\$700,000.00	\$700,000.00	\$700,000.00
52	Construction Management, lot	1	\$0.00	\$0.00	\$625,000.00	\$625,000.00	\$625,000.00
53	Mobilization / Demobilization, lot	1	\$0.00	\$0.00	\$450,000.00	\$450,000.00	\$450,000.00
54	Permitting	1	\$0.00	\$0.00	\$0.00	\$0.00	\$0.00
55	Environmental Compliance & Monitoring	1	\$0.00	\$0.00	\$0.00	\$0.00	\$0.00
<b>SUMMARY</b>							
	Sales Tax (7.8%)			\$59,841.60			
	Summary of Cost			\$827,041.60		\$3,351,000.00	\$4,178,041.60
	Summary of Cost with Contingancy (20%)			\$992,449.92		\$4,021,200.00	\$5,013,649.92
<b>NOTES</b>							

---

## 7.APPENDIX B – ROUTE MAP

---

# ROUTE MAP - 138KV UNDERGROUND STUDY

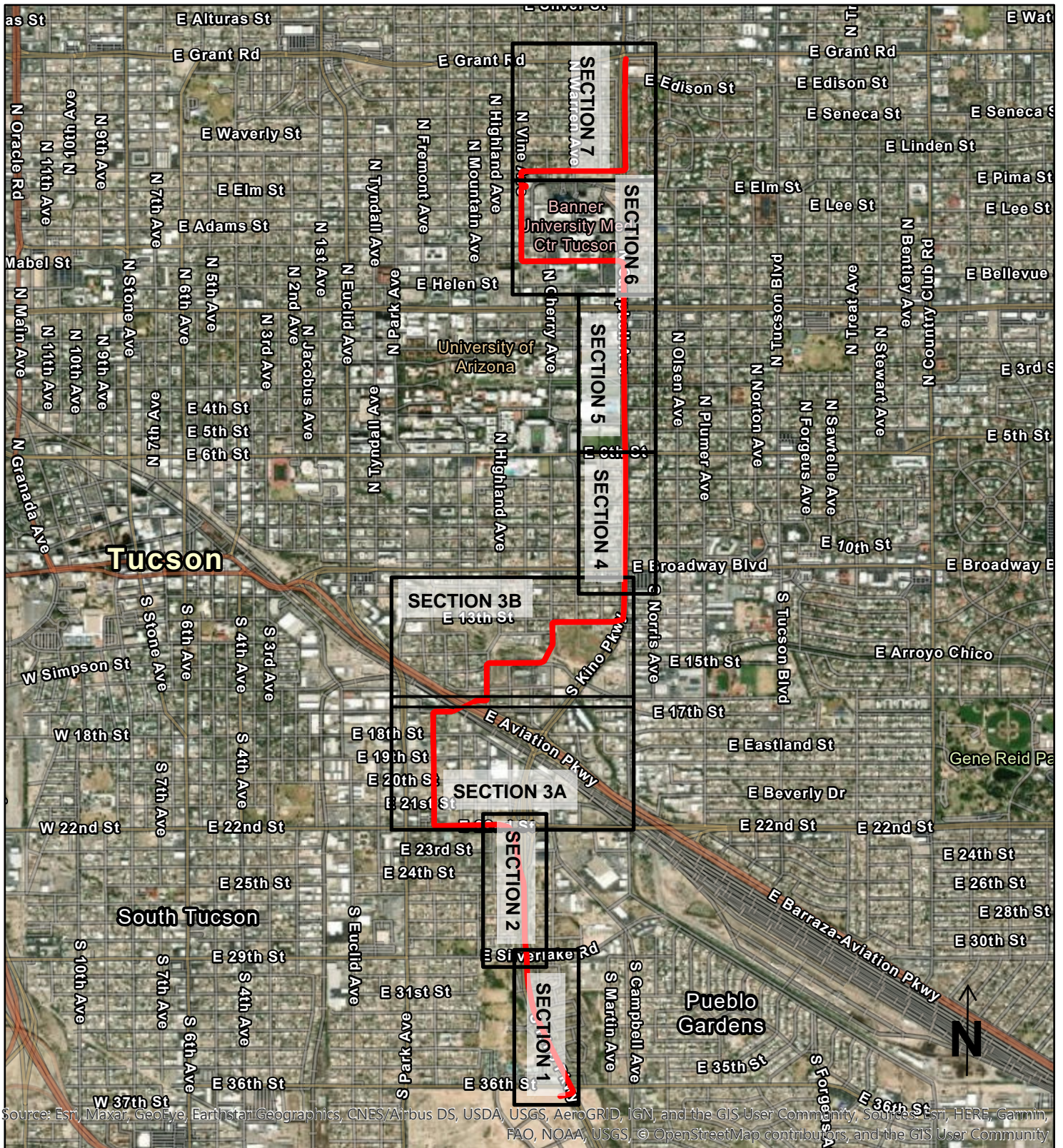

## MAP INDEX

# ROUTE MAP - 138KV UNDERGROUND STUDY



## SECTION 1 - 36TH TO SILVERLAKE

# ROUTE MAP - 138KV UNDERGROUND STUDY

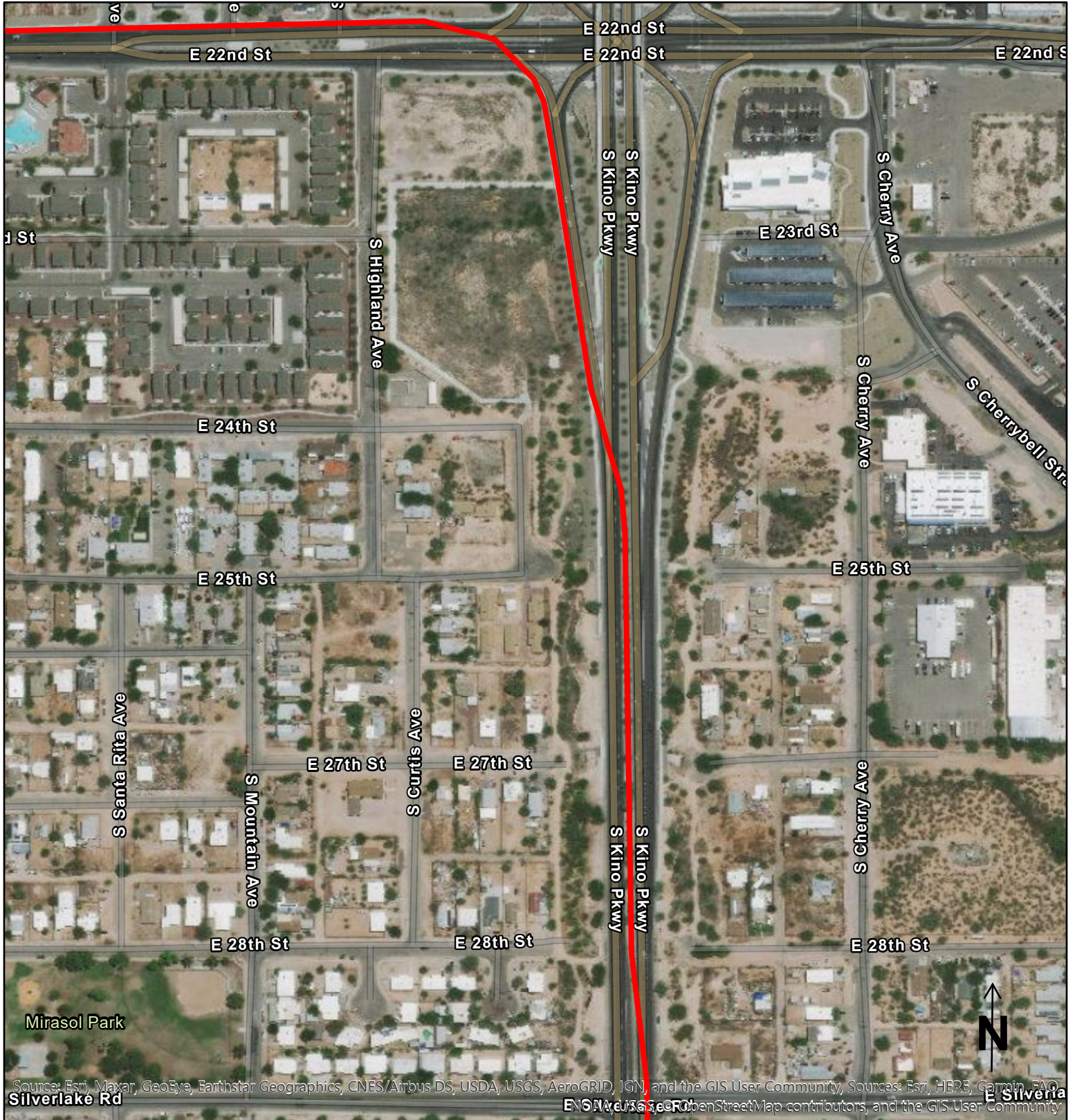

## SECTION 2 - SILVERLAKE TO 22ND

# ROUTE MAP - 138KV UNDERGROUND STUDY



## SECTION 3 - 22ND TO BROADWAY (1 OF 2)



# ROUTE MAP - 138KV UNDERGROUND STUDY



Source: Esri, Maxar, GeoEye, Earthstar Geographics, CNES/Airbus DS, USDA, USGS, AeroGRID, IGN, and the GIS User Community, Sources: Esri, HERE, Garmin, FAO, NOAA, USGS, © OpenStreetMap contributors, and the GIS User Community

## SECTION 3 - 22ND TO BROADWAY (2 OF 2)

# ROUTE MAP - 138KV UNDERGROUND STUDY

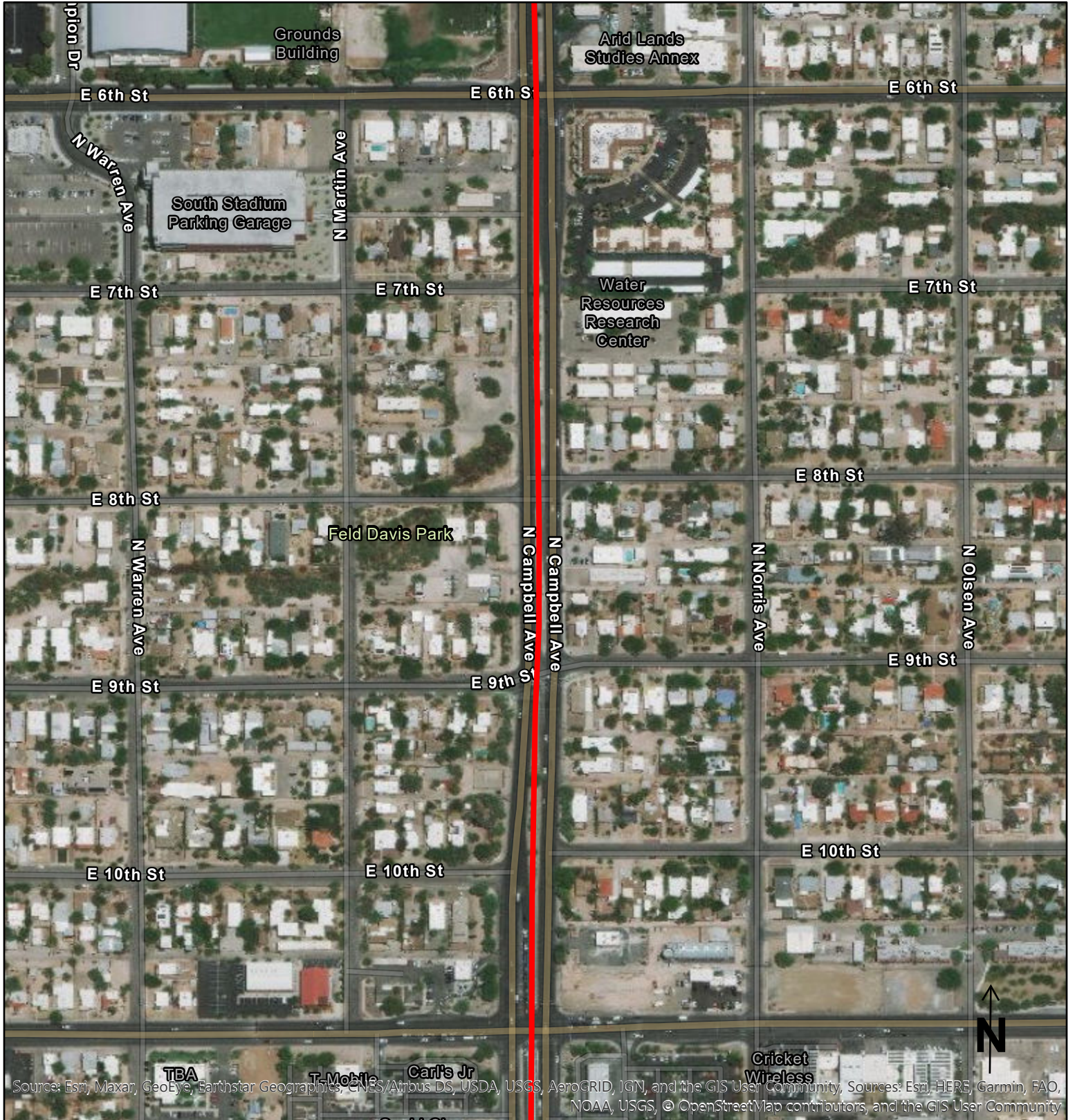

## SECTION 4 - BROADWAY TO 6TH

# ROUTE MAP - 138KV UNDERGROUND STUDY

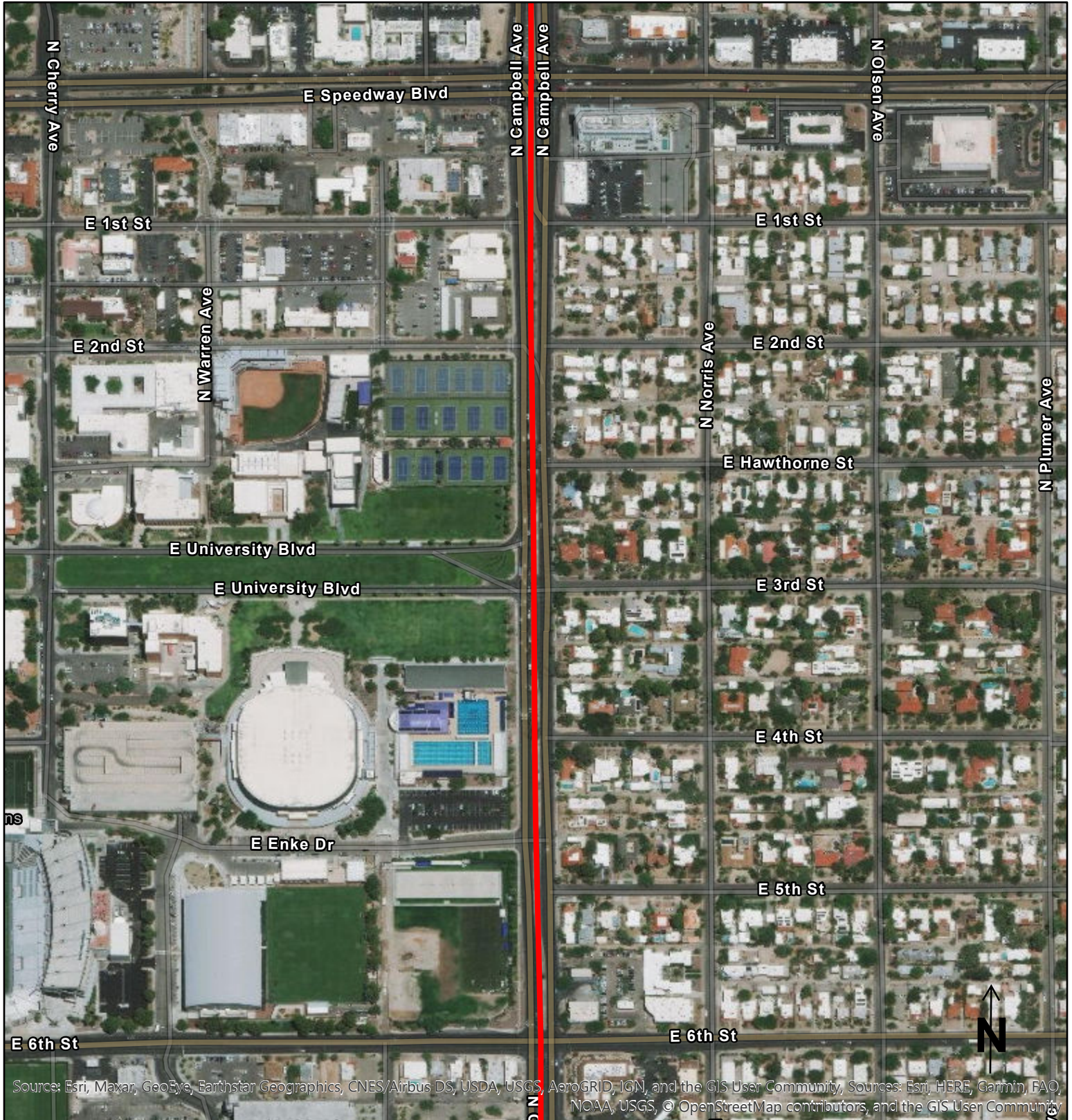

## SECTION 5 - 6TH TO SPEEDWAY

# ROUTE MAP - 138KV UNDERGROUND STUDY

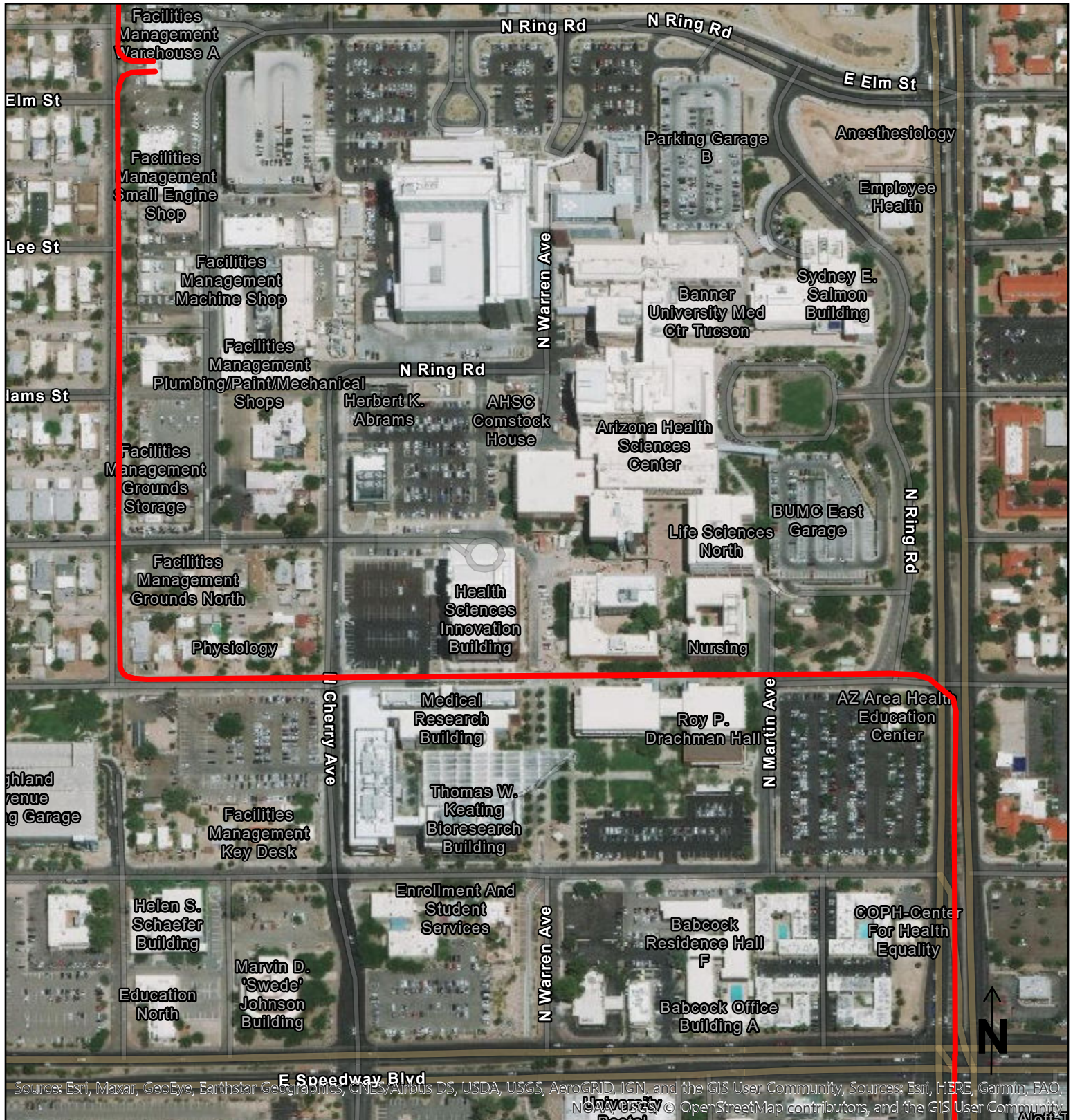

## SECTION 6- SPEEDWAY TO NORTH UA SUBSTATION

# ROUTE MAP - 138KV UNDERGROUND STUDY

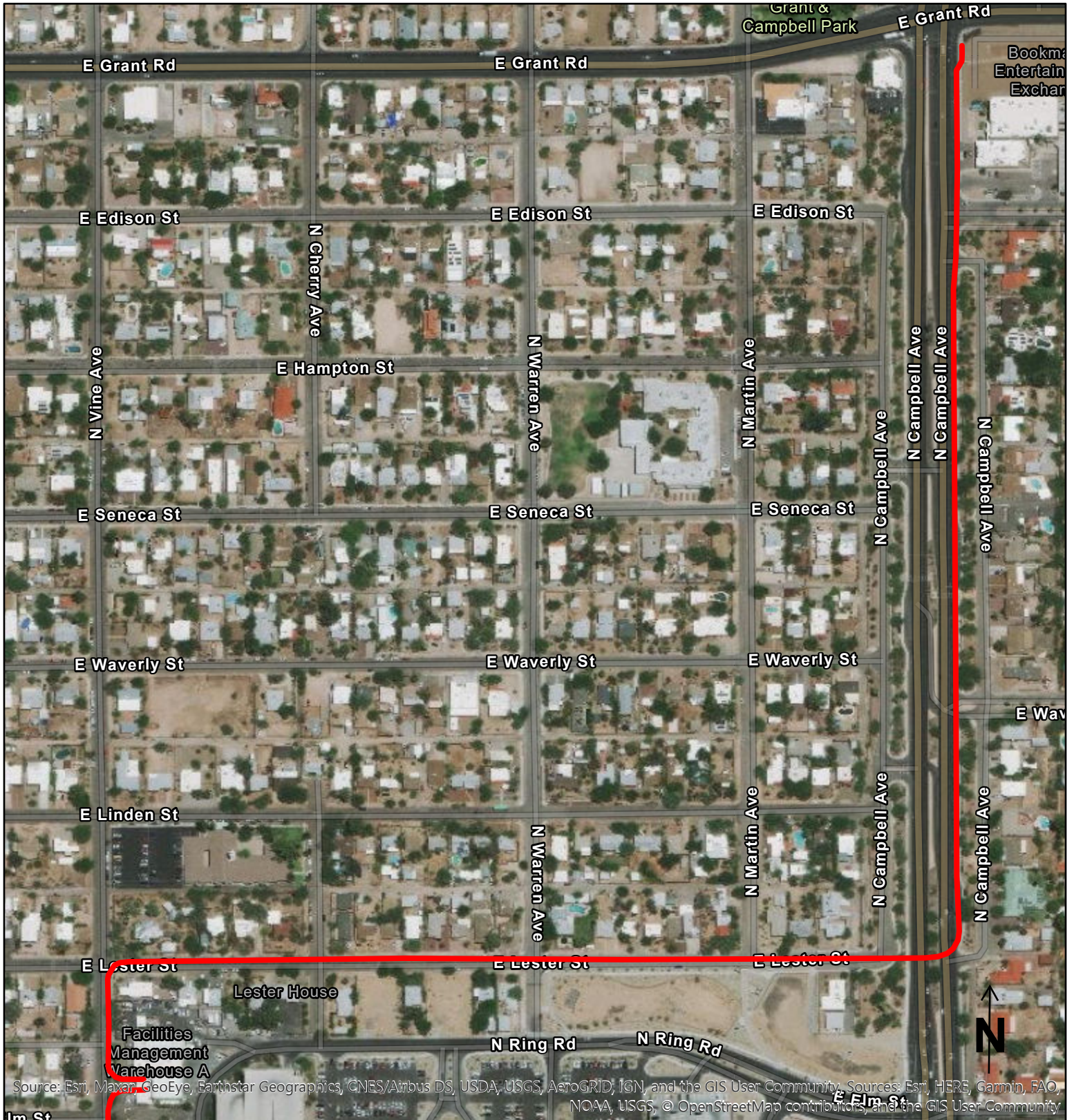

## SECTION 7 - NORTH UA SUBSTATION TO GRANT