



This book is published by Tucson Electric Power Company (TEP) and UniSource Energy Services (UES) Santa Cruz County, as a reference and a guide to its regulations and practices for the connection and supply of electric service. The information and requirements, as referred to in TEP's and UES's rate tariffs and schedules and also mentioned in this book, set forth the general conditions under which electric service will be supplied. The information contained in this book is intended primarily for architects, engineers, contractors, and individual electric service applicants engaged in the planning and construction of buildings or in the installation and replacement of equipment that is to be connected to and served from TEP and UES Santa Cruz County electric distribution system.

The standards for materials and construction referred to in this book are necessary to safeguard all electric service applicants, to provide for the maximum utilization of electric service, and are the minimum under which TEP and UES Santa Cruz County will supply electric service. In the event a condition arises that is not specifically covered in this book, the Service Provider's Design Department should be consulted to determine all applicable requirements.

PROPRIETARY MATERIAL

This material is based on assumptions and criteria which may not be valid outside the Tucson Electric Power Company and UniSource Energy Services Santa Cruz County electric system. The material in this book should not be reproduced for the use of other utilities as Electrical Service Requirements.

Copyright © 2026

Tucson Electric Power Company
UniSource Energy Services, Santa Cruz County



ADDITIONS & REVISIONS

As materials and practices within the utility industry are constantly changing, this book is designed to allow revisions throughout the year. Updates will be posted on The Company's web site 30 days prior to the effective date whenever possible. However, changes due to governmental code and legal requirements may be effective immediately without any prior notification. Any problems that occur as a result of using out of date standards will be the sole responsibility of the book holder and will not be corrected at TEP's and UES's expense.

During the year, updates to the Service Requirements book will be posted on the Internet. Refer to this page at <https://www.tep.com/electric-service-requirements/> to verify any recent updates to the Service Requirements book. This will assure you are using the latest revision.

Throughout the year, Additions & Revisions for 2026



ADDITIONS & REVISIONS TO THE 2025 ELECTRIC SERVICE REQUIREMENTS PRINTING

Please go to the page shown to see updates to this publication.

Additions & Revisions Approved and Published in 2025

SR-101, Pg. 3
SR-105, Pg. 2
SR-107, Pg. 1
Section 200 INDEX
SR-209, Pg. 1-11
SR-214, Pg. 1-4
SR-226, Pg. 1-2*
SR-231, Pg.2
SR-233, Pg. 1-2
SR-236, Pg. 1-3
SR-414, Pg. 1-2*
SR-430, Pg.2*
SR-451, Pg. 1-10
SECTION 700 INDEX
SR-705, Pg.1-2
SR-902, Pg. 1

* Indicates a new addition or change to an item that may affect suppliers.

Revisions contained in this book are indicated by an  or ,

and when delta  is used, the delta number will indicate the

latest drawing revision.

Electric Service Requirement Book Change and Comment Form

This form may be utilized to communicate any recommended changes or comments regarding the information contained or how information is organized within the Electric Service Requirement book. Please complete the form with sufficient detail to communicate clearly any proposed changes and be sure to include the name, address, and telephone number of a person to contact should additional information be required.

Date: _____
Requester Name: _____
Telephone Number: _____
Business Name: _____
E-mail address: _____
Address: _____

Comments: _____

Please send to Distribution Standards at StanEng@tep.com or mail to:
Tucson Electric Power Company
Attn: Distribution Standards – Eileen Dickerson OH107
PO. Box 711
Tucson, AZ 85702

T.E.P. Use Only

Date received: _____
Reviewed by: _____
Date forwarded to ESRC: _____
Reviewed by: _____
Comments: _____

ESRB Updated

Yes _____
No

Action: Approved Under Study Not Approved
Does the Committee action impact the Public? Yes No
Will a Public notification letter need to be sent out? Yes No Sent
Comments: _____

Signed by: _____ Date: _____

You may voluntarily provide the personal information required to complete this form. TEP uses this information to fulfill the purpose for which it was obtained. To find out more about the categories of personal information TEP collects and the purposes for which such information will be used, please refer to our Privacy Policy at <https://www.tep.com/privacy/>.

TABLE OF CONTENTS

<u>TITLE</u>	<u>SECTION</u>
General Information	100
Civil Installations	200
Service Installations	300
Metering Installations	400
Short Circuit Protection	500
Grounding & Bonding	600
Customer Technologies	700
Telecommunication, Wireless and Cable TV Attachments	800
Clearances	900
GIS Drawing Legend	LEGEND

100 SECTION GENERAL INFORMATION

<u>TITLE</u>	<u>SR-No.</u>
Title Block and Logos	100
TEP Contact Information (pg. 1)	
UES Contact Information (pg. 2)	
Government Agency Contact Information (pg. 3)	
One Call - Bluestake, Tree Trimming and Overhead Protection (pg. 4)	101
Definitions	102
<u>Application for Services:</u>	
Type of Service & Limitations	
Preliminary Notification	
Obtaining Information	
Residential/Commercial New Construction	104
<u>Application For Removal:</u>	
Removal of Company Facilities	105
<u>Service, Power Kill, and Access Scheduling</u>	
Scheduling Reminders	
Access to Company Pad Mounted Equipment	
Power Kill Request	106
<u>Line Extensions:</u>	
Qualifications for Three-Phase Service	
Overhead Line Extensions	
Underground Line Extensions	
Subdivision Line Extensions (Single & Three Phase Requirements)	
High Density Development Designs	
Additional Charges	
<u>New Subdivisions:</u>	
Provisions for Service	
Ducts for Road Crossing	107
<u>Rights-of-Way and Easements:</u>	
Rights-of-Way (pg. 1)	
Registered Land Surveyor Information (pg. 2-3)	
Legal Description	
Exhibit Drawing	
Electronic File for Easement	108
<u>Outline for Project Completion:</u>	
Residential	
Commercial	109

100 SECTION
GENERAL INFORMATION

TITLE

SR-No.

Additional Information:

Codes and Regulations
Customer Installations
Access to Premises
Employee Identification
Protection of Company Property
Customer's Equipment
Interruptions
Defaults
Resale of Energy
Attachments to Company Facilities
Energy Diversion
Un-metered Energy

110



EXPLANATION OF COMPANY LOGOS AND TITLE BAR

There are two company logos utilized throughout the Electrical Service Requirements Book (ESRB) that determine whether the specific Service Requirements (SR) is applicable in the Tucson Electric Power (TEP) and/or the Unisource Energy Services (UES) Santa Cruz Service Territory.

An SR with both logos is standardized to apply to projects in the TEP and UES Santa Cruz Service Territories (see Figure 1). If an SR has one logo the requirement is specific to the company indicated (see Figure 2). SR-452 applies to TEP, UES Santa Cruz County and UES Mohave County (see Figure 3).



Any questions as to whether the requirement is applicable to the scope of work on a project should be directed to Design Services for the company providing the service.

Figure 1

		INITIATED BY	CC	REVISION NO.	1	SR-000 Pg. 1 of 1
		ESR COMM.	9-14	ESR COMM.	10-15	
				EFFECTIVE DATE	11-15	

Indicates requirement pertains to TEP

Indicates requirement pertains to UES Santa Cruz

Initials of the requirement author

Current revision on TEP website

Date requirement was first approved

Revision approval date

Date the requirement will become effective

Service Requirement number and page summary

Figure 2

Indicates requirement pertains to TEP only

	INITIATED BY	RS	REVISION NO.	0	SR-000 Pg. 1 of 1
	ESR COMM.	8-78	ESR COMM.	-	
			EFFECTIVE DATE	8-78	

Indicates requirement pertains to UES Santa Cruz only

	INITIATED BY	MS	REVISION NO.	2	SR-000 Pg. 1 of 1
	ESR COMM.	2-84	ESR COMM.	11-16	
			EFFECTIVE DATE	11-16	

Figure 3

Indicates requirement pertains to TEP, UES Santa Cruz & Mohave
ONLY APPLICABLE TO SR-452



		INITIATED BY	HLS	REVISION NO.	3	SR-000 Pg. 1 of 1
		ESR COMM.	8-01	ESR COMM.	11-19	
				EFFECTIVE DATE	11-19	

		INITIATED BY	ME	REVISION NO.	4	SR-100 Pg. 1 of 1
		ESR COMM.	1-07	ESR COMM.	8-22	
				EFFECTIVE DATE	8-22	

CONTACT INFORMATION FOR TUCSON ELECTRIC POWER

Emergency..... (520) 623-3451
 24 hours/day, 7 day/week
 Storm Damage, Hazards to Life/Property, Power Lines Down

Power Kills..... (520) 918-8300
 (Call 5 working days in advance for power kills after charges have been paid)

Access to TEP Equipment..... (520) 918-8300
 (For purpose of duct sweep installation, mandrel pull or installation of customer owned cable)

Line Location Prior to Excavation and Overhead Protection
 Blue Stake Center - Call BEFORE you dig..... 1-800-STAKE-IT or (800) 782-5348 or 811

Design Services
 New Installations-Increases-Relocations-Removals-New Construction
Applications..... (520) 918-8300
Email Address..... schedcoord@tep.com
Fax Number..... (520) 917-8794

4350 E. Irvington Rd	Mailing Address
Tucson, AZ 85714	P.O. Box 711
East of Alvernon Rd, Gate #2	Mail Stop OH202
7:00 a.m. - 3:30 p.m. (Monday-Friday)	Tucson, AZ 85702



Telecommunications Project Manager..... (520) 918-8360
Email Address..... tepjointuse@tep.com

Customer Service..... (520) 623-7711
Telephone Hours
 7:00 am - 7:00 pm (Monday-Friday)
 (Service Connection, Disconnect, Billing Inquiries, Credit, Collection)

General Information..... (520) 571-4000
 8:00 am - 5:00 pm (Monday-Friday)
 (Assistance for contact of other departments within TEP)

Tucson Electric Power Company	Internet Address:
88 E. Broadway	http://www.tep.com
Tucson, AZ 85701	

	INITIATED BY	GC	REVISION NO.	7	SR-101 Pg. 1 of 4
	ESR COMM.	8-06	ESR COMM.	6-19	
			EFFECTIVE DATE	6-19	

**CONTACT INFORMATION FOR
UNI SOURCE ENERGY SERVICES NOGALES
SANTA CRUZ COUNTY**

Emergency.....(877) 837-4968
24 hours a day, 7 days a week
Storm Damage, Hazards to Life/Property, Power Lines Down

Power Kills.....(520) 761-7951
(Call 5 working days in advance for power kills after charges have been paid)

Access to UES Equipment.....(520) 761-7951
(For purpose of duct sweep installation, mandrel pull or installation of customer owned cable)

Line Location Prior to Excavation and Overhead Protection
Blue Stake Center - Call BEFORE you dig.....1-800-STAKE-IT or (800) 782-5348 or 811

Design Services
New Installations-Increases-Relocations-Removals-New Construction
Applications.....(520) 761-7951
FAX Number.....(520) 761-7947



Mailing Address
861 W. Mariposa Rd.
Nogales, AZ 85621

Customer Service.....(877) 837-4968
Telephone Hours
7:00 am - 7:00 pm (Monday-Friday)
Service Connection, Disconnect, Billing Inquiries, Credit, Collection, General Information

Internet Address
<http://www.uesaz.com>

Customer Service E-Mail Address
nogalescustomerservice@uesaz.com

Governmental Agencies (See page 3)

	INITIATED BY	GC	REVISION NO.	5	SR-101  Pg. 2 of 4
	ESR COMM.	7-05	ESR COMM.	9-18	
			EFFECTIVE DATE	9-18	

CONTACT INFORMATION FOR GOVERNMENTAL AGENCIES

Permits and inspections will be required by governmental agencies before The Company will install electric cable or set a meter on. For information on obtaining permits, please contact the appropriate governmental agency.

TEP Governmental Contacts:

City of South Tucson
1601 S. 6th Ave
Tucson, AZ 85713
(520) 792-2424
(520) 364-1067

Arizona Dept. of Manufactured Housing
Department of Building & Fire Safety
400 W. Congress Street, Suite 121
Tucson, AZ 85701
(520) 628-6920

City of Tucson
Development Services Center
201 N. Stone Ave
Tucson, AZ 85701
(520) 791-5550

Town of Marana
Planning & Zoning
13555 N. Sanders
Marana, AZ 85653
(520) 382-2600

Pima County
Development Services Center
201 N. Stone Ave
Tucson, AZ 85701
(520) 724-9000

Town of Oro Valley
Planning & Zoning
11000 N. La Canada Drive
Oro Valley, AZ 85737
(520) 229-4800

Town of Sahuarita
Public Works
P.O. Box 879
Sahuarita, AZ 85629
(520) 822-8866

Pascua Yaqui Tribe
Design Construction Services
4543 W. Calle Torim
Tucson, AZ 85757
(520) 879-6337



Arizona Dept. of Administration *
General Services Division
1400 W. Washington, Suite B200
Phoenix, AZ 85007
(602) 390-7089

UES Governmental Contacts:

City of Nogales
Public Works
1450 N Hohokam Drive
Nogales, AZ 85621
(520) 287-7245



Santa Cruz County
Building Department
275 Rio Rico Drive
Rio Rico, AZ 85648
(520) 375-7830

Notes:

Be sure to take out the proper governmental permit.
Manufactured homes in the County require both County & State Clearances.
*State Wide Jurisdiction on the State of Arizona owned properties



FORMERLY SR-1.07

 	INITIATED BY	ED	REVISION NO.	8	SR-101 Pg. 3 of 4
	ESR COMM.	8-06	ESR COMM.	8-25	
			EFFECTIVE DATE	8-25	

**CONTACT INFORMATION
ONE CALL - BLUESTAKE, TREE TRIMMING,
AND OVERHEAD PROTECTION**

Line Location Prior to Excavation



Arizona Revised Statutes, Sec. 40-360.21 through Sec. 40-360.28 requires that persons excavating in a public right-of-way or utility easement obtain information concerning underground utility locations in the area before excavating. Under the statutes, excavation is defined as any disturbance of the ground surface which includes the setting of property pins. To request information or field location of electric lines, call the "Blue Stake Center", 1-800-STAKE-IT (1-800-782-5348) at least two working days prior to excavation.

High Voltage Power Lines And Safety Restrictions

Care must be taken by the customer in making installations of antennas or other facilities near or adjacent to Company lines so that under all conditions the installation will not be under or fall across Company lines nor contact them in any way, and thereby constitute a hazard to life and property. The customer will not approach (within 10 feet) any overhead high voltage conductors of Company without the prior written consent from Service Provider. For activity near overhead power lines, see Arizona Revised Statutes 6.4, Sections 40-360.41 through 45. If activity is near overhead power lines, call the "Blue Stake Center," 1-800-STAKE-IT (1-800-782-5348) and request an "overhead spot".

Trimming Trees



The customer must notify the Blue Stake Center and request an overhead spot at 1-800-STAKE-IT prior to trimming in the proximity of overhead conductors of Company. The customer shall permit Service Provider to trim or remove any trees or other vegetation that may interfere with the safe operation of Company's facilities.

 	INITIATED BY	EKD	REVISION NO.	0	SR-101 Pg. 4 of 4
	ESR COMM.	9-18	ESR COMM.	-	
			EFFECTIVE DATE	9-18	

DEFINITIONS

Applicant:	Any person, firm, corporation, organization, entity or governmental agency applying for service from the Company.
Company:	Tucson Electric Power (TEP) or UniSource Energy Services (UES) acting through its duly authorized officers or employees within the scope of their respective duties.
Connected Load:	The sum of the power rating of the customer's electrical apparatus connected to a Company meter.
Construction Drawing:	A drawing showing electrical facilities.
Crew:	Group of Company Journeyman.
Customer:	Any person, firm, corporation, organization, entity or governmental agency purchasing, utilizing, or prepared to utilize service from the Company under its Rules and Regulations at one location.
Demand:	The average rate at which energy is delivered during any specified period of time. Demand is normally expressed in kilowatts and measured over a 15 minute time period.
 Design Services:	Company Designer, Planner, Field Technician, Scheduling Coordinator or New Service Representative.
Distribution Lines:	Overhead (OH) or Underground (UG) lines operated by the Company at distribution voltage, which are constructed along public highways, bona fide rights-of-way, and including rights-of-way on customer's property.
Energy Diversion:	A loss of revenue as a result of a customer tampering with or bypassing Company metering or distribution equipment.
Line Work:	The installation of Company facilities such as poles, transformers, junction boxes, cable, wire, or any work other than installation of the service.
Month:	The period between any two regular readings of the Company's meter(s) at approximately 30-day intervals.
Point of Delivery:	The location on the customer's building, structure, or premise where all wires, conductors, or other current-carrying devices of the customer join or connect with wires, conductors or other current-carrying devices of the Service Provider.
Point of Delivery (Three-Phase Underground):	Secondary terminals at the Service providers pad-mounted transformer.
Preliminary Electric Design:	Preliminary drawing showing electrical facilities provided to the Customer for review and approval prior to completion of construction drawing.



 	INITIATED BY	GC	REVISION NO.	3	SR-102 Pg. 1 of 2
	ESR COMM.	8-06	ESR COMM.	6-21	
			EFFECTIVE DATE	6-21	

DEFINITIONS

Service Work: Any work required to run the service line.



Service: The last cable or wire extending from an overhead (OH) or underground (UG) Company facility to the customer's project.

Service Provider: Tucson Electric Power (TEP) or UniSource Energy Services (UES) acting through its duly authorized officers or employees within the scope of their respective duties.

TEP: Tucson Electric Power

UES: UniSource Energy Services - Santa Cruz County



 	INITIATED BY	GC	REVISION NO.	3	SR-102 Pg. 2 of 2
	ESR COMM.	8-06	ESR COMM.	6-21	
			EFFECTIVE DATE	6-21	

APPLICATION FOR SERVICE



Type of Service & Limitations

Upon the customer's request, the Service Provider will specify the type of distribution service available (voltage and number of phases) at any given location for utilization by the customer. Service shall be provided through one service connection at one point of delivery for each unique customer premise. Customers with facilities requiring more than one service voltage are responsible for providing those additional voltages through their own means (e.g. step-down transformers). Customers with loads exceeding the limits defined below may be required to receive primary metered service. The electric energy furnished will be alternating current 60 hertz, single or three-phase at one of the following standard nominal voltages, subject to the limitations shown:

Single-Phase (Residential & General Service or Light and Power Customers)

120 volts, 2-wire (30A maximum service entrance size) is no longer available for new service and is for maintenance only. 120/240 volts, 3-wire from pole mounted transformer is limited to 100kVA maximum load and/or 600A maximum service entrance size. 120/240 volts, 3-wire from pad-mounted transformer is limited to 167kVA maximum load and/or 800A maximum service entrance size. Loads of 530A or more will require 2-4 inch duct systems for parallel service conductor.

Three-Phase (General Service or Light and Power Customers)

240/120 volt, 4-Wire Delta: Is no longer available for new service and is for maintenance only or an upgrade of an existing three-phase service per limitations for OH and UG service. This voltage is not available from Company's underground distribution system. When available, service is limited to 600A maximum service entrance size for underground service from pole mounted transformers and to 1200A maximum service entrance size for overhead service from pole mounted transformers.

208Y/120 volt, 4-Wire: Limited to 3000A maximum service entrance size for underground service from a pad mounted transformer, limited to 1600A maximum service entrance size for overhead service from pole mounted transformers, and limited to 600A maximum service entrance size for underground service from pole mounted transformers. Not available for service to mobile home lots per NEC 550-21.

480Y/277 volt, 4-Wire: This service will also be provided for all 480 volt three-phase, three-wire services unless otherwise specified by Service Provider. Limited to 4000A maximum service entrance size for underground service from a pad mounted transformer, limited to 800A maximum service entrance size for overhead service from pole mounted transformers, and limited to 600A maximum service entrance size for underground service from pole mounted transformers.



The maximum size for customer owned underground service conductors to Company's equipment is 600kcmil.

TEP:

4,160/2,400 volt, 4-Wire: Primary metered service available only at TEP's option.*

13,800Y/7,970 volt, 4-Wire: Primary metered service available only at TEP's option.*

UES:

13,200/7,620 volt, 4-Wire: Primary metered service available only at UES's option.*

*Refer to SR-451 for primary metered service requirements.

		INITIATED BY	GC	REVISION NO.	7	SR-104
		ESR COMM.	8-06	ESR COMM.	1-20	
				EFFECTIVE DATE	1-20	Pg. 1 of 9

APPLICATION FOR SERVICE

Temporary Service

The Service Provider will install temporary service to a customer providing the customer pays the estimated installation and removal cost as well as the normal monthly billings on the electric meter. It is imperative that the customer make application for temporary service by calling TEP at (520) 918-8300 or UES at (520) 761-7951 at the earliest possible time as any jobs requiring a meter and service will fall into our normal construction schedules. The installation and removal cost must be paid prior to the release of the job for construction. For details on the overhead and underground temporary services, please refer to the appropriate SR standards.

Notice to Applicants

TEP

The default Pricing Plan for Temporary Service and Commercial Service is GS-10. The default Pricing Plan for Residential Service is R-01.

UES Santa Cruz

The default Pricing Plan for Temporary Service and Commercial Service is EGSGS. The default Pricing Plan for Residential Service is ERRES.

For services other than Temporary, Commercial, and Residential, please consult the Pricing Plans listed at tep.com or uesaz.com. Upon application for service or upon request, the applicant or customer will select the applicable Pricing Plan best suited to his or her requirements. The Company may assist in making this election, but will not be held responsible for notifying the Customer of the most favorable Pricing Plan, and will not be required to refund the difference in charges under different Pricing Plans.



Preliminary Notification

To aid architects and engineering firms in providing the Company with advance notification and preliminary engineering data and to obtain the location from which a new building will be served, these firms should submit plans for new buildings and projects with a New Construction Application. This will enable the Service Provider to provide more complete information with minimal delay to these firms and eliminate some of the problems in the early facilities design stage. This form does not supersede the Company's present application requirements, but is a supplemental aid.

Obtaining Service

In order to obtain service at the time desired, application should be made as early as possible. There are no fees for making an application. An appropriate Governmental Agency electrical permit must be obtained and the permit number submitted with the New Construction Application. It is important to keep the Company informed as to the progress of the project and anticipated date that service will be needed. See SR-104 for TEP and UES New Construction Applications.

FORMERLY SR-1.05 & SR-1.06

 TEP Tucson Electric Power	 UniSourceEnergy SERVICES SANTA CRUZ COUNTY	INITIATED BY	GC	REVISION NO.	3	SR-104 
		ESR COMM.	8-06	ESR COMM.	9-18	
				EFFECTIVE DATE	9-18	

Tucson Electric Power Residential / Commercial New Construction Application

PLEASE PRINT

Date: _____ Permit No: _____
 Required date: (date you need power): _____

A. Official Address Information

Official Service Address: _____
 City: _____ Zip Code: _____
 Lot#: _____ Subdivision Name: _____
 Legal: T _____ R _____ S _____ Q _____

B. Responsible Party for Billing- Residential

Primary Name: _____ Telephone#: _____
 Spouses Name: _____
 Mailing address: _____
 Social Security number: _____ Driver's License: _____
 Employer: _____ Address: _____
 Telephone#: _____ Other TEP accounts: _____

C. Responsible Party for Billing- Commercial

Business Name: _____ Primary Number: _____
 Business Type: Corp: _____ Partnership: _____ LLC: _____ Sole Proprietor: _____
 Officer/Partner/Owner Name _____

(Person with Authority to Accept Financial Responsibility for the Account)

Phone Number for above: _____ Tax ID: _____
 Mailing address: _____

D. Contact Information

Site Contact Name: _____ Telephone#: _____
 Company Name: _____ Cellular #: _____
 Company Address: _____ Pager #: _____

E. Electrical Information

Type of Service:
 New Service: _____ Increase: _____ Temporary: _____ Relocation: _____ Removal: _____
 Underground (UG): _____ or Overhead (OH) _____ Voltage _____
 Single Phase: _____ or Three Phase _____ Amperage: _____
 Power kill required: Yes _____ No _____ Unknown _____ Building Square footage _____
 Solar Installation Electric Vehicle
 Cooling & Heating Equipment:
 A/C Tonnage: _____ or Evap: _____
 Heat pump tonnage: _____ or Gas: _____

F. Additional Information: _____

NOTICE TO APPLICANTS:

THE DEFAULT PRICING PLAN FOR TEMPORARY SERVICE AND COMMERCIAL SERVICE IS GS-10. THE DEFAULT PRICING PLAN FOR RESIDENTIAL SERVICE IS R-01. FOR SERVICES OTHER THAN TEMPORARY, COMMERCIAL, AND RESIDENTIAL, PLEASE CONSULT THE PRICING PLANS LISTED AT TEP.COM.

BE SURE TO SEND A COPY OF THE OFFICIAL ADDRESS AND LEGAL DESCRIPTION OF THE PROPERTY TO DESIGN SERVICES.

- IF 1 ACRE PARCEL OR LARGER, ALSO SEND SITE PLAN
- IF OVER 200 AMPS, ALSO SEND ELECTRICAL PLANS.
- BE SURE TO OBTAIN THE PROPER GOVERNMENTAL PERMITS
- UPON RECEIPT OF ALL ABOVE INFORMATION, THE AREA FIELD TECH OR DESIGNER WILL CONTACT YOU WITHIN 5 WORKING DAYS

Mail To:

Design Services
 P.O. Box 711 Mail Stop OH202
 Tucson, Arizona 85702
 Fax # 520-917-8794

Governmental Agencies

City of South Tucson (520) 792-2424 Town of Marana (520) 382-2600
 City of Tucson (520) 791-5550 Town of Oro Valley (520) 229-4800
 Pima County (520) 740-6490 Town of Sahuarita (520) 822-8866
 *Az. Dept. of Manufactured Housing (520) 628-6920
 (*Manufactured Homes require City/County and State Clearances)

FORMERLY SR-1.13



INITIATED BY	GC	REVISION NO.	7	SR-104
ESR COMM.	8-06	ESR COMM.	9-18	
		EFFECTIVE DATE	9-18	

ELECTRICAL NEW CONSTRUCTION APPLICATION - RESIDENTIAL

Kingman: ph 928-681-8922 Fax 928-681-8920
2498 Airway Ave, Kingman, AZ 86409

Lake Havasu: ph 928-505-7016 Fax 928-505-7032
2749 Maricopa Ave, Lake Havasu City, AZ 86406

Nogales: ph 520-761-7951 fax 520-761-7947
861 W Mariposa Rd, Nogales, AZ 85621 Toll
Free: 877-UES-4YOU (837-4968)

Applicant Information

Full Name: Last _____ First _____ Middle Initial _____

Business Name (If Applicable) _____

Mailing Address _____ City _____ State _____ Zip _____

Home Phone _____ Work Phone _____

Cell or Message Phone _____ Employer Name _____

Social Security No _____ Driver's Lic No/State _____

Nearest Relative _____ Phone _____ Relationship _____

Date (estimate) for when you need power: Month _____ Day _____ Year _____

Spouse Information (If no spouse, please write None)

Spouse Name _____ Work Phone _____

Social Security No _____ Employer Name _____

Service Location Information

Service Address _____ Cross Street _____ City _____ Zip _____

Legal Description: Tract ____ Block ____ Lot ____ Subdivision _____ Township ____ Range ____ Section ____ City County

Is this property zoned A-R Agricultural – Residential? Yes ____ or No ____ (Mark one)

If yes, will there be more than one residential dwelling on this property? Yes ____ or No ____ (Mark one)

Parcel No: (Example: 310-06-025) _____

Type of Residence: House Mobile Home RV/Other: _____

Livable Square Footage: _____ AMPS: 100 200 Other: _____

If structure is a manufactured building, date it will be moved into: _____

Type(s) of Service: Permanent Construction Dusk to Dawn Light Underground

Temporary Construction Non-Permanent (RV) Overhead

Service Upgrade Change in Service

Note: The residential temporary construction fee will be determined by the Engineering Department. Other rules and fees may apply according to the Rules and Regulations approved by the Arizona Corporation Commission. "Electric Service Installation Requirements" booklets available online at www.uesaz.com, by mail or in local office.

Builder/Contractor/Manufactured Home Dealer _____ Phone _____

Electrician _____ Phone _____

Note: UniSource requires the Applicant to complete this Application and submit a plot plan. The Applicant is responsible for notifying UniSource when service pole and service entrance are installed and ready for service (City, County and/or State Inspections may be required prior to connection). A security deposit is required when meter is set or, in lieu of a cash deposit, a letter of credit from a previous electric utility company may be submitted. Established good credit with UniSource Energy Services is also acceptable.

Signature _____ Date _____



INITIATED BY

ED

REVISION NO.

0

SR-104

ESR COMM.

9-18

ESR COMM.

-

Pg. 4 of 9

EFFECTIVE DATE

9-18

ELECTRICAL NEW CONSTRUCTION APPLICATION - RESIDENTIAL (Plot Plan)

Legal Description: Township _____ Range _____ Section _____
 Subdivision _____
 Block _____ Lot _____ Parcel _____
 Address _____

Please enter the following Information:

1. Property boundary dimensions, dimensions of all existing and proposed structures, and distances between all buildings.
2. Location of public utility easement(s).
3. Location of septic tank(s) and leach field(s).
4. Location of proposed service entrance.

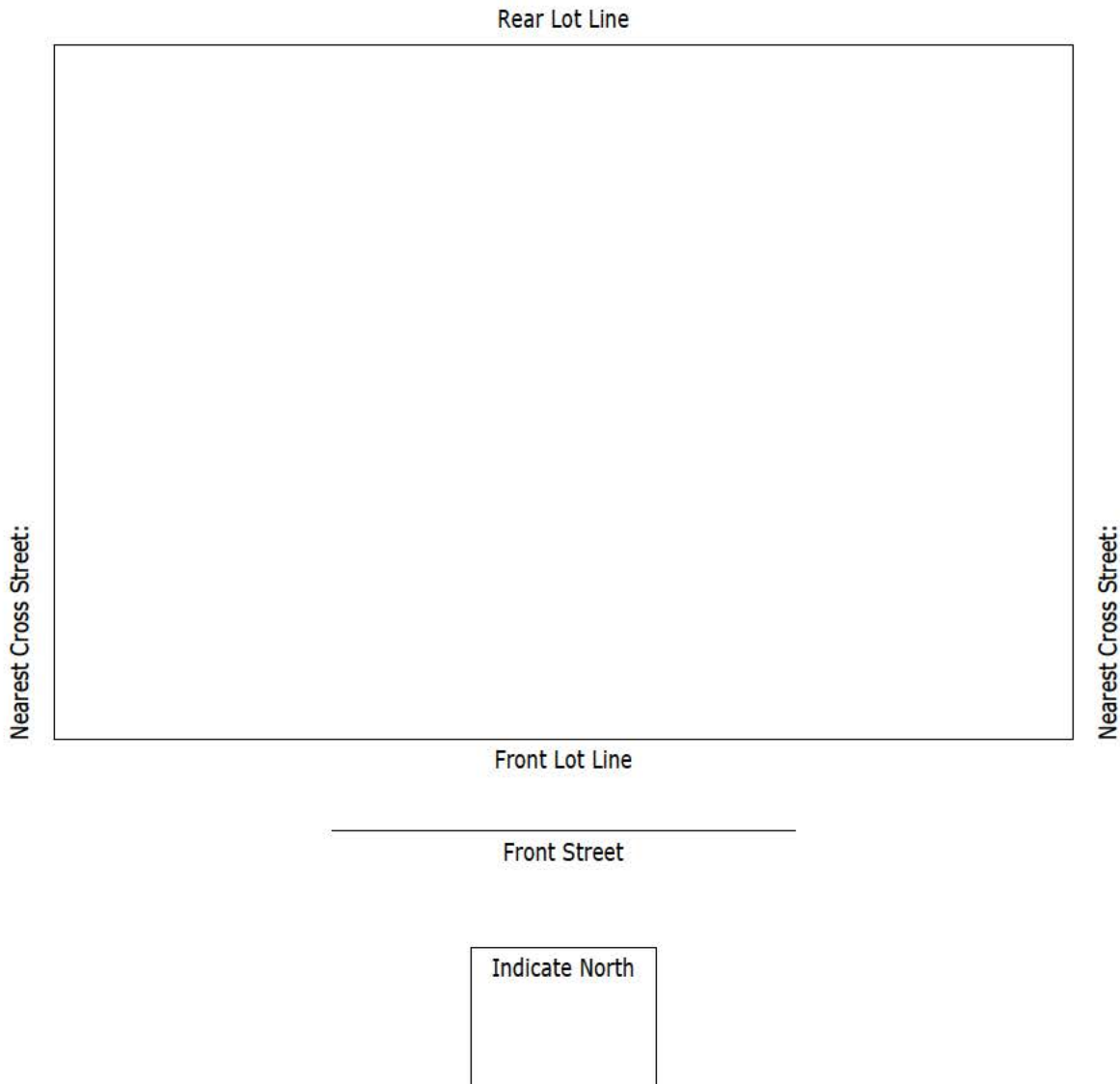

INITIATED BY	ED	REVISION NO.	0
ESR COMM.	9-18	ESR COMM.	-
		EFFECTIVE DATE	9-18

SR-104
Pg. 5 of 9

ELECTRICAL NEW CONSTRUCTION APPLICATION - RESIDENTIAL (Plot Plan Example)

Legal Description: Township 10N Range 10W Section 10
 Subdivision Sunny Arizona Ranchos, Unit 10
 Block 10 Lot 10 Parcel 111-22-333
 Address 1010 Your Property Street

Please enter the following Information:

1. Property boundary dimensions, dimensions of all existing and proposed structures, and distances between all buildings.
2. Location of public utility easement(s).
3. Location of septic tank(s) and leach field(s).
4. Location of proposed service entrance.

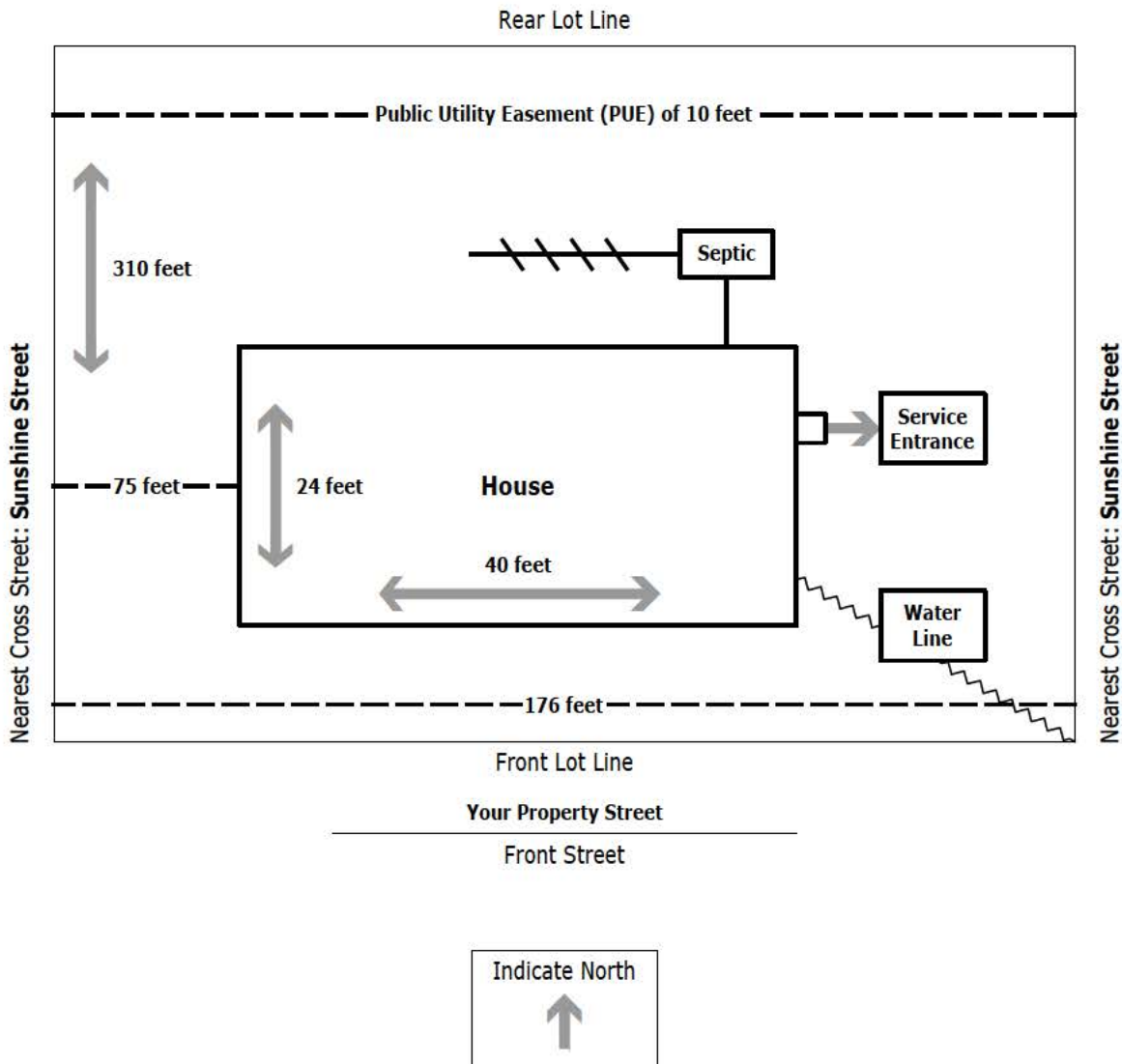

ELECTRICAL NEW CONSTRUCTION APPLICATION - COMMERCIAL

Kingman: ph 928-681-8922 Fax 928-681-8920
2498 Airway Ave, Kingman, AZ 86409

Lake Havasu: ph 928-505-7016 Fax 928-505-7032
2749 Maricopa Ave, Lake Havasu City, AZ 86406

Nogales: ph 520-761-7951 fax 520-761-7947
861 W Mariposa Rd, Nogales, AZ 85621 Toll
Free: 877-UES-4YOU (837-4968)

Applicant Information

Business Name _____ C/O _____

Responsible Party or Owner _____

Work Phone _____ Message Phone _____

Cell Phone _____ Social Security No. _____

Mailing Address _____ City _____ State _____ Zip _____

Billing Address _____ City _____ State _____ Zip _____

Date (estimate) for when you need power: Month _____ Day _____ Year _____

Business Information

Partnership Corporation Sole Owner Other: _____

Tax ID No. _____ Type of Business _____

Service Location Information

Service Address _____ Cross Street _____ City _____ Zip _____

Legal Description:

Tract _____ Block _____ Lot _____ Subdivision _____ Township _____ Range _____ Section _____ City County

Parcel No: (Example: 310-06-025) _____

AMPS: 100 200 Other: _____

If structure is a manufactured building, date it will be moved into: _____

Square Footage _____ Voltage _____

Type(s) of Service: Permanent Construction Dusk to Dawn Light Underground
 Temporary Construction Non-Permanent (RV) Overhead
 Service Upgrade Change in Service

Note: The commercial temporary construction fee will be determined by the Engineering Department. Other rules and fees may apply according to the Rules and Regulations approved by the Arizona Corporation Commission. "Electric Service Installation Requirements" booklets available online at www.uesaz.com, by mail, or in the local office. All services must meet E.U.S.E.R.C. (Electric Utility Service Equipment Requirements Committee) standards.

Builder _____ Phone _____

Electrician _____ Phone _____

Note: UniSource requires the Applicant to complete this Application and submit a site plan and electrical load requirements. The Applicant is responsible for notifying UniSource when service pole or service entrance is installed and ready for service (City, County and/or State Inspections may be required prior to connection). A security deposit is required, and the amount will be determined prior to meter set. In lieu of a deposit, a Surety Bond may be submitted.

Signature _____ Date Requested _____



INITIATED BY

ED

REVISION NO.

0

SR-104

ESR COMM.

9-18

ESR COMM.

-

Pg. 7 of 9

EFFECTIVE DATE

9-18

ELECTRICAL NEW CONSTRUCTION APPLICATION - COMMERCIAL (Plot Plan)

Legal Description: Township _____ Range _____ Section _____
 Subdivision _____
 Block _____ Lot _____ Parcel _____
 Address _____

Please enter the following Information:

1. Property boundary dimensions, dimensions of all existing and proposed structures, and distances between all buildings.
2. Location of public utility easement(s).
3. Location of septic tank(s) and leach field(s).
4. Location of proposed service entrance.

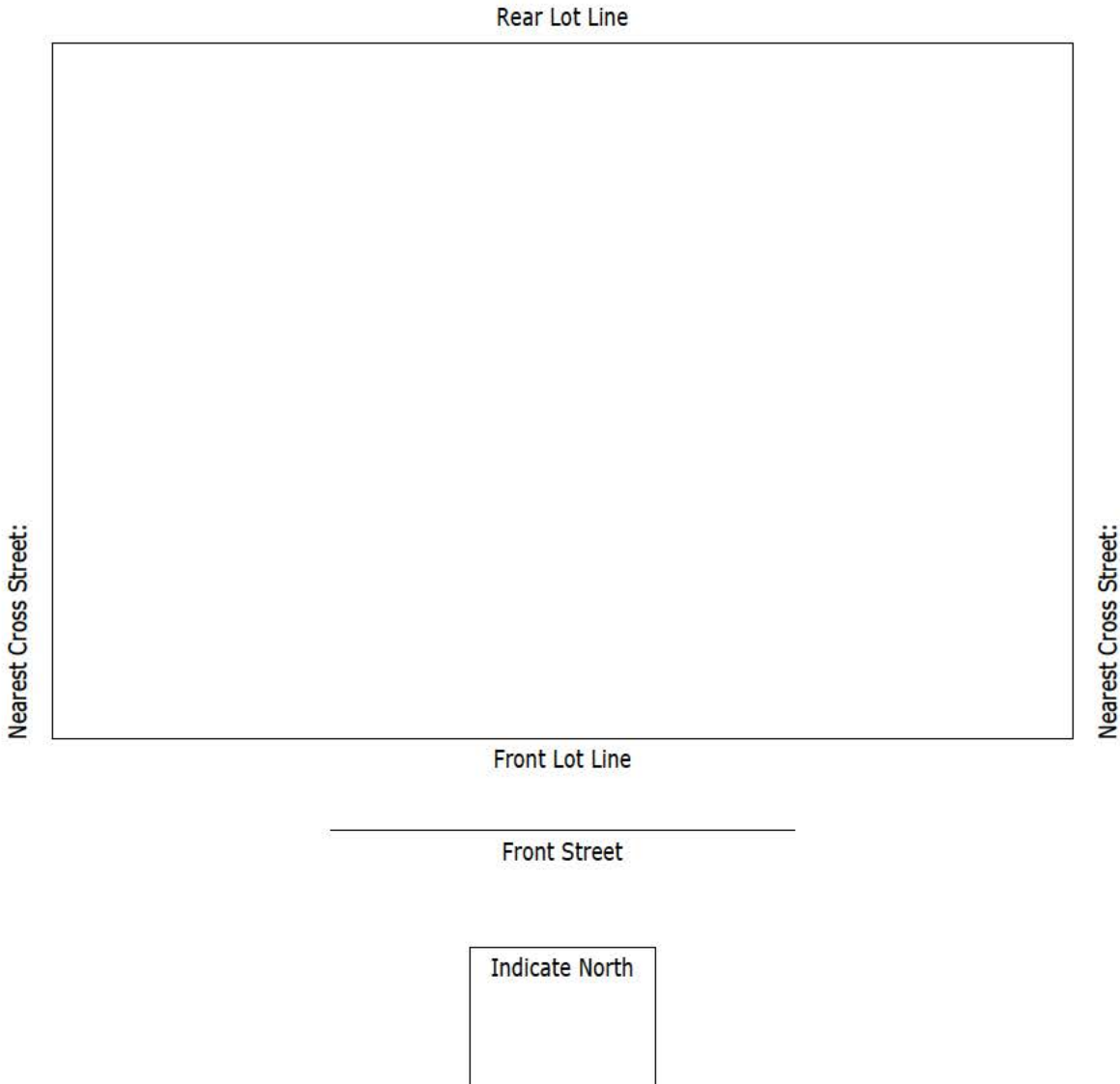

ELECTRICAL NEW CONSTRUCTION APPLICATION - COMMERCIAL (Plot Plan Example)

Legal Description: Township 10N Range 10W Section 10
 Subdivision Sunny Arizona Ranchos, Unit 10
 Block 10 Lot 10 Parcel 111-22-333
 Address 1010 Your Property Street

Please enter the following Information:

1. Property boundary dimensions, dimensions of all existing and proposed structures, and distances between all buildings.
2. Location of public utility easement(s).
3. Location of septic tank(s) and leach field(s).
4. Location of proposed service entrance.

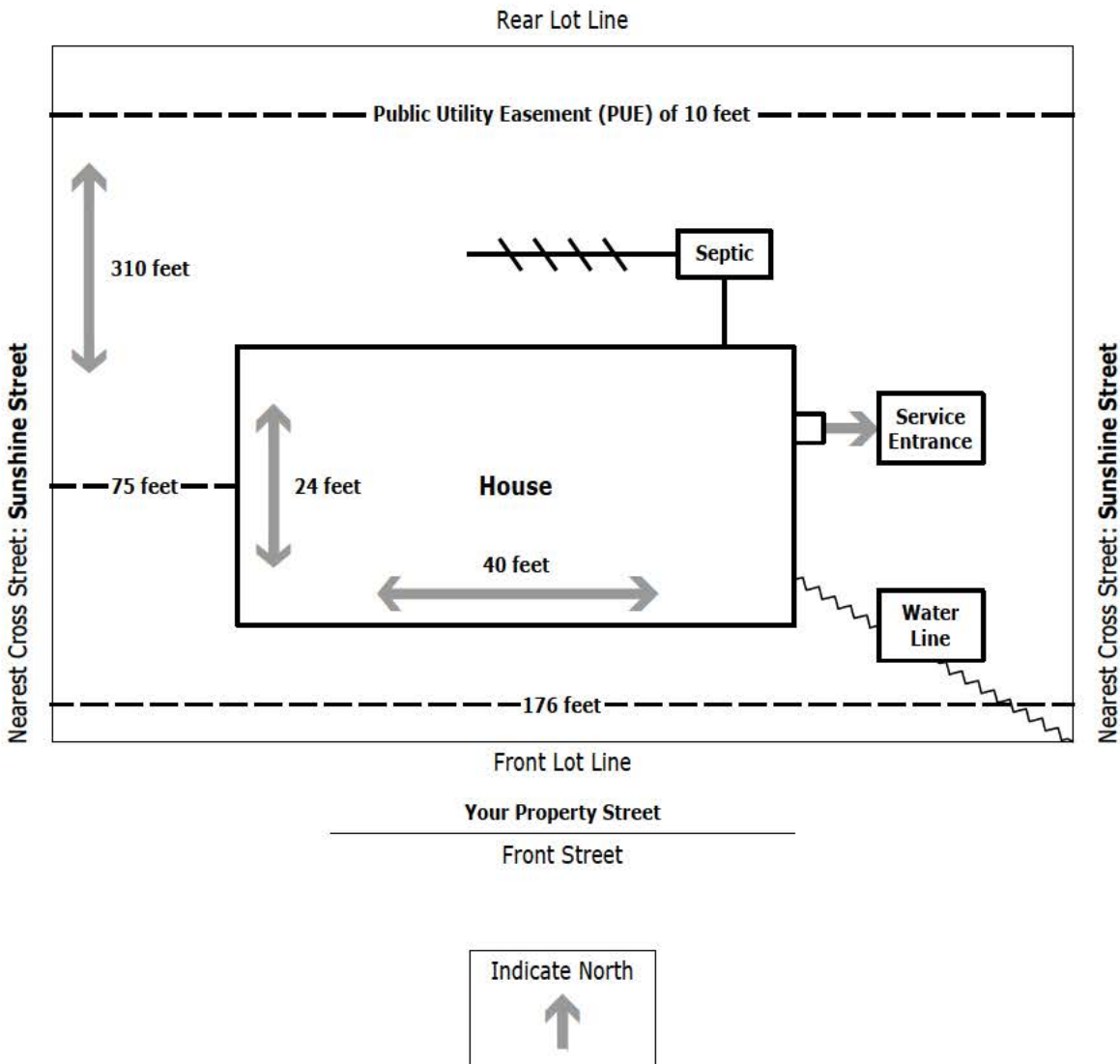



APPLICATION FOR REMOVAL

Removal of Company Facilities

Requests for the removal of Company facilities (Services/Distribution lines) for the purpose of demolishing of buildings or sites for development, will be made in writing. Utilize Removal Letter, Internet access at www.tep.com, or by telephone at (520) 918-8300 or Internet access at www.uesaz.com or by telephone at (520) 761-7951. Please be sure to include the account and meter number. Due to normal construction scheduling, a minimum of two weeks (10 working days) notice will be given to Service Provider prior to the date the service(s) are to be removed. If line work is required, Service Provider will remove the Distribution facilities within 90 days. Contact the new business Project Manager to verify scheduling.

FORMERLY SR-1.13A

		INITIATED BY	GC	REVISION NO.	2	SR-105  Pg. 1 of 2	
		ESR COMM.	8-06	ESR COMM.			9-18
				EFFECTIVE DATE			9-18

Application for Removal

PLEASE PRINT

Tucson Electric Power Company

PO Box 711, OH202
Tucson, Arizona 85702

Date: _____

Request for removal of electric service facilities: (Incomplete information may delay request)

I request the removal of electrical service facilities at the following address:

Meter number **(Required)**: _____

Reason for removal: _____

Requested completion date: _____

Tucson Electric Power Company (TEP) cannot accommodate any removal requests that are not in writing and signed by the owner of subject property. A TEP Field Technician will perform a site inspection within two weeks from receipt of written request.

Property Owner (Please Print): _____

Mailing Address: _____

Signature: _____ Phone number: _____

Name (Please Print): _____

Completed form may be mailed, faxed or e-mailed to Tucson Electric Power.

Mailing Address:

Tucson Electric Power Company
Attention: Design Services
P.O. Box 711
Mail Stop OH-202
Tucson, Arizona 85702



Fax number:

Attention: Design Services
Ph# (520) 918-8300

E-Mail:

designservices@tep.com

FORMERLY SR-1.13A

		INITIATED BY	GC	REVISION NO.	3	SR-105 
		ESR COMM.	8-06	ESR COMM.	8-25	
				EFFECTIVE DATE	8-25	



SERVICE, POWER KILL, AND ACCESS SCHEDULING

Service Provider will schedule and install services (both new and increases), *not requiring line and/or transformer work*, on a daily basis as crew loading permits, but usually not more than five working days after the governmental agency inspection clearances are received by the Service Provider from the agency having jurisdiction. However, this time frame may be extended depending upon crew availability and inclement weather.

Reminders:

1. For current year the Holidays are: Memorial Day, 4th of July, Labor Day, Thanksgiving (Thursday and Friday), and (2) days on or around the December 25th holiday for Company employees.
2. Permanent addresses should be on switch panels before requesting governmental inspections and must agree with the address on permit and new construction application.
3. Please be aware that there may be as much as a 24-hour time delay in notifications to the Service Provider from the governmental inspection agencies after they have made their inspection in the field. This will result in service work not being released until the following workday.



Access To Company Pad Mounted Equipment

Only employees and authorized contractors of Service Provider are permitted entry into the Company's pad-mounted equipment. When it becomes necessary for a customer or contractor to install duct sweeps, mandrel a duct or pull cable inside the Company equipment, arrangements must be made by calling TEP at (520) 918-8300 or UES at (520) 761-7951. All requests must be made with a minimum of 5 working days advance notice and will be scheduled as Service Provider's work schedule allows.

Power Kill Request

All charges are due and payable before the Company can take a request for a scheduled power outage. Appointments can be made by contacting TEP at (520) 918-8300 or UES at (520) 761-7951. Requests must be made 5 working days prior to the time the outage is required. All requests will be scheduled in the order they are received and as Service Provider's work schedule allows. Work requiring access to an enclosure which has been sealed by the Company must be approved by Service Provider for the specific job or location.

FORMERLY SR-1.06

 	INITIATED BY	ED	REVISION NO.	7	SR-106  Pg. 1 of 1
	ESR COMM.	8-06	ESR COMM.	9-18	
			EFFECTIVE DATE	9-18	

LINE EXTENSIONS



Service Provider will make a distribution line extension over the shortest feasible route. Service Provider may agree to an extension over an alternate route provided the customer pays all additional costs. Extensions must begin from a Company circuit of the appropriate size, phase, and voltage class required to serve the subject customer project. For example, a customer requesting three-phase 600A primary service will require an extension from a Company three-phase 600A primary line. A 600A primary extension cannot be made from a three-phase 200A primary line or from a single-phase 200A primary line. Likewise, a customer requesting three-phase secondary service will require, at minimum, a three-phase 200A primary line extension; a single-phase primary extension will not suffice for three-phase service.

For line extensions, when a customer is requesting or required to be served from an existing underground line, the extension must remain underground from the beginning to the end of the installation. If an overhead line extension is requested the extension must remain overhead from the beginning to the end of the installation. A combination of overhead and underground line extension is not allowed. Note: Local Governing Codes may prohibit overhead line extensions, in specific areas.

QUALIFICATIONS FOR THREE-PHASE

General Service or Light and Power Customers qualify for a three-phase line extension under the standard line extension policy if either of the following applies:

1. Customer has a minimum service entrance rating of 400A (which may be the sum of two 200A services grouped together and served from the same transformer).
2. Customer has a single three-phase motor rated 10hp or greater.

For three-phase line extensions where these requirements are not met, the customer will be required to pay the additional line extension cost from the point of origin as per the Company Rules and Regulations governing Special or Excess Facilities. Residential Customers do not qualify for three-phase service.

OVERHEAD LINE

Free Allowance



Upon an applicant's satisfactory completion of required site improvements, Service Provider will make extensions from its existing overhead facilities of proper voltage and adequate capacity free of charge a distance of up to 1,000 feet for TEP and 550 feet for UES Santa Cruz. The distance will be measured by the shortest feasible route along public streets, roads, highways, or suitable easements from the existing facilities to the applicant's point of delivery. Line extensions to temporary services, unusually small loads not consisting of a residence or a permanent occupied building will not be granted the free allowance.

Deposit

For overhead line extensions in excess of the free allowance, a non-interest bearing cash deposit must be made for the cost of the excess footage. The Company will refund the deposit under the terms of the contract for each permanent customer connected to the overhead extension for which the deposit was made. Any new connection made to a refundable line extension that requires its own separate contract, will not be applied as a refund connection. The total refund will not exceed the amount of the initial deposit.

 Tucson Electric Power	 UniSourceEnergy SERVICES SANTA CRUZ COUNTY	INITIATED BY	GC	REVISION NO.	8	SR-107 Pg. 1 of 4
		ESR COMM.	8-06	ESR COMM.	7-25	
				EFFECTIVE DATE	7-25	

LINE EXTENSIONS



UNDERGROUND LINE

In addition to any required deposit for the length of the distribution line (see Overhead Line Extensions) the customer will be required to pay the difference in cost between an underground line extension and an equivalent overhead line extension as a non-refundable cash payment. The customer may, with the consent of the Company and in accordance with Company Standards, provide trenching, backfilling (with necessary imported fill), conduit system, pole risers, pull boxes, switch bases and pads as part of the overhead- underground differential payment. The customer is also responsible for the installation any other civil material provided by Service Provider as noted in a Company Construction Drawing.

SINGLE PHASE UNDERGROUND LINE

The overhead/underground differential payment for single-phase underground line extensions to individuals as well as within subdivisions is usually satisfied if the customer provides all trenching, backfilling (including any imported backfill required), compaction, repaving, and all earthwork required for equipment pad sites. Service Provider reserves the right to design any single phase underground distribution system in a duct. For such installations, the following basic rules are applied.



1. All trenches shall comply with Company's trenching and backfill requirements (joint and non-joint trenches).
2. Property corner pins must be identified and left in place and/or re-established in place for Company inspectors' use in placing stakes for transformers, pull boxes, J1's, pedestals and backfill inspections.
3. The customer is responsible for the trench and/or excavation being properly located within specified easements and/or rights-of-way. All relocation costs resulting from improperly located trenches shall be borne by the customer.

THREE-PHASE UNDERGROUND LINE

The overhead/Underground differential payment for the three-phase underground line extensions is usually satisfied by the customer providing all earthwork and installing all necessary ducts, concrete pads, pole risers and other appurtenances as specified on the applicable Company Standards for these items. Each installation will require advanced layout and approval by Service Provider as to satisfying the differential cost in this manner. The customer is responsible for the trench and/or excavation being properly within specified easements and/or right-of-way. All relocation costs resulting from improperly located trenches shall be borne by the customer.

1. Layout of the electrical system completed.
2. Obtain easements and agreements as possible.
3. Customer installs duct system and calls for inspection before backfilling the trench. Any concrete encased duct must be inspected prior to and after the pouring of concrete, but prior to backfilling the trench. After duct has been inspected and passed, customer to shade duct and install other utilities. A minimum of one foot separation is required between Company's and other utilities.
4. Customer completes backfill and compaction as required.
5. Customer installs Company approved precast pad.
6. Customer installs pull rope and calls for mandrel inspection. Note: All contingencies must be satisfied prior to mandrel inspection including any billable costs, deposits and/or easements.



		INITIATED BY	GC	REVISION NO.	4	SR-107 Pg. 2 of 4
		ESR COMM.	10-05	ESR COMM.	11-21	
				EFFECTIVE DATE	11-21	

LINE EXTENSIONS



THREE-PHASE UNDERGROUND LINE (CONTINUED)

7. Service Provider installs the primary cable and pad-mounted transformer(s). Service point of delivery is typically at the secondary terminals in the transformer. Customer to furnish and install service conductors from the Company transformer to the customers switchgear. The service conductor size will be no greater than 600kcmil.

SUBDIVISION LINE

Contracts for extensions made up to the perimeter of a duly recorded subdivision will be determined by the total footage of cable or wire and the class of line that is required to be extended in order to serve the new project/future load.

Contracts for extensions made inside of a duly recorded subdivision is determined by the total cable footage required to serve the subdivision and the number of lots being installed and energized under one contract.

HIGH DENSITY DEVELOPMENT DESIGNS

Due to the tight nature of these developments some of the Service Requirements standards may be difficult to obtain. However, all Service Requirements are necessary for the safe operation and maintenance of the utility facilities and must be followed. Planning for these requirements early in the design phase ensures the best outcome for all parties. The following list of Service Requirements highlights common areas of concern pertaining to this type of design. This list is not all inclusive and the entire Service Requirements Book should be used to ensure compliance with all standards.

1. SR 208 - Site Preparation for Equipment Pads on Sloping Grades
2. SR 209 - Trenching, Underground Residential Distribution (U.R.D.)
3. SR 215 - Trenching 2.5", 4" and 6" Conduit Installation
4. SR 230 - Equipment Barrier, Protective
5. SR 312 - Trenching, Service (Single-Phase)
6. SR 405 - Metering Installations (General Requirements)
7. SR 418 - Residential or Commercial Service, Multi-Metering Installations
8. SR 452 - Approved Metering and Service Equipment

You may contact Design Services for TEP at (520) 918-8300 and for UES at (520) 761-7951 to help work through concerns and ensure compliance with these and all standards.

NEW SUBDIVISIONS - PROVISIONS FOR SERVICE

Arrangements for the extension of electric facilities to a new subdivision are made through the Land Management Department and the Contracts Coordinator.

The developer must provide:

1. A sepia copy of the recorded plat or development plan.
2. Construction contract deposit.
3. Differential payments as required for underground extensions.

		INITIATED BY	GC	REVISION NO.	4	SR-107
		ESR COMM.	8-06	ESR COMM.	11-21	
				EFFECTIVE DATE	11-21	Pg. 3 of 4

LINE EXTENSIONS



NEW SUBDIVISIONS - PROVISIONS FOR SERVICE (CONTINUED)

4. Easements as required for the distribution extension, and any rights-of-ways necessary for approach lines must be dedicated on the plat. Additional easements may also be required and will be provided by a separate instrument in a form acceptable to Service Provider.
5. The area of installation shall pass all inspections before the electric distribution lines can be installed. Transformer pads and pedestals must be level at final grade prior to installing cable, transformers and terminating pedestals.
6. Individual lot boundaries shall be identified and remain identified until the distribution system has been installed.



DUCTS FOR ROAD CROSSING

Should a developer wish to pave or backfill areas prior to the installation of the remaining conduit system, the developer shall install the conduit(s) of the size and type which the project has been designed for by Service Provider. See per SR-210 for the specifications. If the conduit(s) is being installed for future use, the developer shall be responsible for providing Design Services with a dimensioned "As Built" drawing showing the exact location of the conduit(s) and install per SR-218. The cost of pavement cuts or boring necessitated by lack of conduit(s) or the inability to locate such conduit(s) shall be borne by the developer.

ADDITIONAL CHARGES

In addition to the normal cost associated with the installation of distribution facilities, the customer may be charged for the following:

1. The costs associated with problems caused by changes in apartment numbers.
2. The cost of alternate designs requested by the customer.
3. The cost of facilities in excess of Service Provider's standard installation, which are requested by the Customer and would not otherwise be required to provide adequate service.
4. Other costs of nonrecurring nature, specifically associated with the proposed installation.
5. The cost associated with any installation change to an approved construction drawing, or deviation from Electrical Service Requirement book standards without prior approval from Design Services, is subject to Billable charges. These changes may include the cost of additional material, labor and engineering time.
6. When electric facilities are damaged in the course of excavation or in any other manner, the total cost of repair will be borne by the party responsible for the damage.
7. Company inspectors do not verify grade stakes. Any adjustments required to grade and/or pad sites due to inaccurate grading, grade changes and/or improper grade establishment at trench or pad sites will be the responsibility of the Developer/Contractor. Any associate costs to correct grade or pad sites and any costs incurred by Service Provider due to a change in surface elevation will be borne by the customer.
8. Service Provider may agree to relocate existing facilities if the customer provides all required right-of-way and pays in advance all costs of the relocation.

 Tucson Electric Power	 UniSourceEnergy SERVICES SANTA CRUZ COUNTY	INITIATED BY	GC	REVISION NO.	5	SR-107  Pg. 4 of 4
		ESR COMM.	8-06	ESR COMM.	11-21	
		ESR COMM.	8-06	EFFECTIVE DATE	11-21	

RIGHTS-OF-WAY AND EASEMENTS

CUSTOMER PROVIDED RIGHTS-OF-WAY AND EASEMENTS

1. Service provider shall be granted all rights-of-way and easements in a form acceptable to and at no cost to company for the erection, maintenance, repair, replacement, and removal for use of all distribution facilities necessary or convenient for the supplying of electric service to the customer. It is the responsibility of the customer to provide such easements and rights-of-way.
2. The customer will also provide free, safe, and unimpaired access at reasonable times to the premises of the customer for the purpose of reading meters, testing, repairing, removing or exchanging any or all equipment belonging to company. Service provider may discontinue service after proper notice issued, if violations of this right of free, safe, and unimpaired access continues to occur.

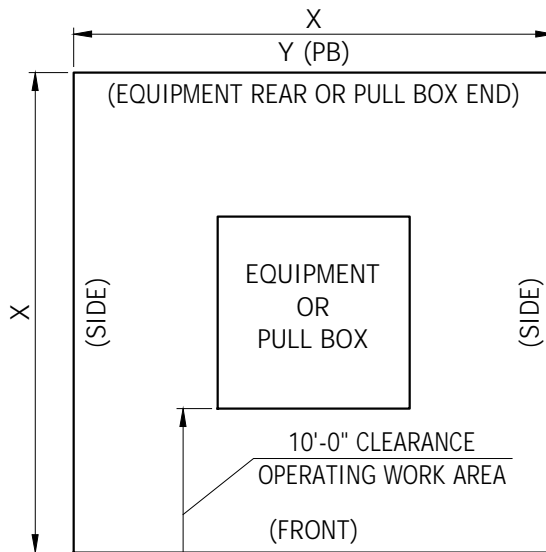



FIGURE 1

EASEMENT LINE (X BY X OR Y)

- X = 10 FT. FOR SECONDARY PEDESTAL, J10 & J30 (SEE SR-209, PAGE 4 & 5).
- X = 10 FT. FOR SINGLE-PHASE TRANSFORMER & J1 CABINET (SEE SR-209, PAGE 3 & 6).
- X = 10 FT. FOR J2 AND F2 CABINET (SEE SR-234 OR SR-242).
- X = 15 FT. FOR PMH/PME/VISTA SWITCHGEAR (SEE SR-240 AND SR-232).
- X = 15 FT. FOR THREE-PHASE TRANSFORMER (SEE SR-233).
- X = 15 FT. FOR THREE-PHASE CAPACITOR (SEE SR-233 AND SR-241).
- X = 15 FT. FOR THREE-PHASE J-6. (SEE SR-236).
- Y = 15 FT. FOR THE WIDTH OF PULL BOX (SEE SR-225).
- X = 20 FT. FOR THE LENGTH OF PULL BOX (SEE SR-225).
- 10 FT. STRIP FOR UNDERGROUND PRIMARY, SECONDARY AND SERVICES.
- 10 FT. STRIP FOR UNDERGROUND 46kV.
- 18 FT. STRIP FOR OVERHEAD DISTRIBUTION POLE LINES.
- 5 "VARIES" STRIP FOR OVERHEAD 46KV AND 138KV POLE LINES.

NOTE: REFER TO COMPANY ISSUED CONSTRUCTION DRAWING FOR PROJECT SPECIFIC EASEMENTS AND REQUIRED ACCESS OR ACCESS EASEMENTS.



		INITIATED BY	JKC	REVISION NO.	5	SR-108 Pg. 1 of 3
		ESR COMM.	12-15	ESR COMM.	10-24	
				EFFECTIVE DATE	10-24	

RIGHTS-OF-WAY AND EASEMENTS

Registered Land Surveyor Information

This section outlines the requirements which the professional land surveyor must consider when preparing a legal description and exhibit drawing for a proposed easement on behalf of their client, our customer. These requirements are provided to achieve an optimum degree of uniformity of product submitted to the Company.

1. Legal description will be prepared and stamped by a Professional Land Surveyor in good standing registered in the State of Arizona.
2. The submitted legal description for an easement to be granted shall meet the criteria set forth in Section 14 of the PDF titled, "Arizona Boundary Survey Minimum Standards," available on the Arizona Board of Technical Registration website. Page size must be 8.50 x 11.00 inches in portrait orientation.
3. An exhibit drawing must accompany the legal description to visually support the written narrative (see requirements below).



Legal Description

Caption

1. Indicate use in a general manner, such as: "An electric easement within a portion of..." DO NOT state specific use (i.e., particular type of equipment nor its use as overhead or underground).
2. State geographic location by:
 - a. Reference to a government land division within the U.S. Public Land Survey System, a Land Grant, a Reservation, a Homestead, etc.
 - b. Lot or parcel (number or letter), block or tract within a county recorded subdivision identifying said County Recorder's Office and the recordation number of said subdivision.
 - c. Citation of the recorded deed of the parcel of land the easement will encumber.

Body

1. A clearly stated basis of bearing, referencing two existing, physically described controlling monuments.
2. Sufficient data to enable a mathematical verification of the easement being inscribed within the property being encumbered.
3. Where described, curve segments shall contain sufficient information to allow verification of the data by mathematical analysis. Curves are presumed to be circular and tangent. All other non-tangent and/or non-circular curves must be noted in the description.
4. Identify and note any existing, recorded electric easement(s) which is/are intended to join with the new easement as a continuous, uninterrupted land right.
5. Report the total area of the easement(s) in square feet when less than an acre (rounded to the nearest foot) or in acres when area exceeds 43,560 square feet (three places to right of the decimal).

		INITIATED BY	JKC	REVISION NO.	4	SR-108  Pg. 2 of 3
		ESR COMM.	12-15	ESR COMM.	4-23	

RIGHTS-OF-WAY AND EASEMENTS

Exhibit Drawing

1. Page size to be 8.50 x 11.00 inches (ANSI A).
2. Title block must state the township, range, section(s) and meridian of the easement location.
3. A north arrow.
4. If applicable, a line table and/or curve data will be shown.
5. Note assessor's parcel number (APN) of affected parcel.
6. The county recording number of the deed of the underlying parcel.
7. Boundary lines shown of all parcels affected by the easement.
8. Depict existing, recorded electric easement(s) which is/are intended to join with the new easement.

Deliverables



In an effort to operate and maintain a geographic information system (GIS) for both corporate land rights and facility mapping purposes, the Company now requires delivery of specific electronic files by the customer.

1. An original, stamped paper final draft which meets County recording requirements based on A.R.S. 11-480.
2. CAD file of the results of survey drawing (AutoCAD 2005 or newer) (.DWG or .DXF) geo-referenced to the minimal standard of Arizona State Plane Grid Coordinate System NAD83/HARN92, AZ Central Zone, State Plane Int'l Feet. Newer published National Spatial Reference System (NSRS) datums by the NGS such as NAD83(CORS96), NAD83(2007) and NAD83(2011) are acceptable. Please note as part of the required metadata file.
3. Metadata text file (include projection, datum, project name, Company/Firm, name of preparer and date).

Resources

Below are a resources for geodetic control for GPS RTK localization of an easement survey:

- PCDOT/TDOT geodetic control points found at <http://gis.pima.gov/maps/mapguide/>
- NOAA NGS Survey Marks and Datasheets site <http://www.ngs.noaa.gov/datasheets/>
- Santa Cruz County (AZ) Public Works Department, a comprehensive control survey by CPE Consultants LLC (March 2014) titled, "[Santa Cruz County GIS Control Monument Survey](#)"
- NOAA NGS OPUS online positioning solution of a GPS static session <http://www.ngs.noaa.gov/OPUS/>



		INITIATED BY	EKD	REVISION NO.	1	SR-108  Pg. 3 of 3
		ESR COMM.	9-19	ESR COMM.	4-23	
				EFFECTIVE DATE	4-23	



Residential Underground Project Outline

Customer Responsibilities	Service Provider Responsibilities
<p><u>Step 1</u>-Customer contacts Company's Design Services Department, refer to SR-101 for contact information. Customer provides the following:</p> <ol style="list-style-type: none"> 1) Residential New Construction Application information 2) Site plan if (1) acre or larger, and legal description of the property 3) Electric load plan if over 200 amps 4) Electrical Permit Number 	<p><u>Step 2</u>-Design Services reviews the plans and provide a Preliminary Electrical Design drawing for the customer within 20 days (if necessary). The Preliminary Electrical Design will include the Electrical Service Requirements specifications, easement requirements (if required) and the need for a contract and/or costs for the project (if required)</p>
<p><u>Step 4</u>-Customer approves or requests changes of the Preliminary Electrical Design. Customer signs the approval letter & faxes it to the assigned Scheduling Coordinator (if one is sent to the customer).</p>	<p><u>Step 3</u>-An Approval Letter is mailed to the customer by Design Services. This correspondence will include the Preliminary Electrical Design Drawing, related Electrical Service Requirements, and the request for a legal description and sketch for the new easement (if required).</p>
<p><u>Step 6</u>-If required, customer submits the original copies of the legal description and sketch written by a Registered Land Surveyor (RLS).</p>	<p><u>Step 5</u>-Design Services prepares a final Construction Drawing of the electrical system. Copies are sent to the customer and other utilities (<u>not all utilities receive copies</u>, customer to inquire with each utility) within 20 days.</p>
<p><u>Step 8</u>-Customer signs, notarizes the easement and returns to Service Provider.</p>	<p><u>Step 7</u>-Design Services forwards the legal description & sketch to Company Land Department to review and prepare for the customers signature. The prepared easement package is sent to the customer within 20 days.</p>
<p><u>Step 10</u>-Customer executes the agreement and returns it to Service Provider, if required.</p>	<p><u>Step 9</u>-Design Services prepares any required Billable estimates. The Company sends the agreement to the customer (i.e. Line Extensions, Prior to Improvements, etc.)</p>
<p><u>Step 12</u>-Customer may contact Design Services prior to starting construction, either by phone (to answer any questions) or an on site pre-construction meeting (if required).</p>	<p><u>Step 11</u>-Design Services sends the "Approved for Construction Drawing" and correspondence letter <u>AFTER</u> the easements and/or Agreements are received.</p>
<p><u>Step 13</u>-Customer to stake out the easement for the trenching contractor and Service Provider's inspector. The contractor digs the trench, (refer to the trenching & conduit installation specifications per the approved construction drawing) installs the conduit system (including any service stubs) and calls for inspection.</p>	<p><u>Step 14</u>-Service Provider's representative inspects the trench and conduit system and notifies the customer if Passed or Failed the inspection.</p>
<p><u>Step 15</u>-Customer calls for a concrete encasement inspection (if required) prior to backfilling the trench.</p>	<p><u>Step 16</u>-Design Services representative inspects the concrete installation and notifies the customer if Passed or Failed the inspection.</p>
<p><u>Step 17</u>-Customer shades the trench with 1 ft. of backfill over Service Provider's conduit system (if joint trench with other utilities and installs other utilities), then backfills the remainder of the trench (100%) and establishes final grade. Compacts & levels the pad site, installs pad per SR-209 & SR-208. Customer calls for the transformer pad site , pedestal site and mandrel inspections.</p>	<p><u>Step 18</u>-Service Provider's representative inspects the backfill, transformer site, pedestal site, J1 sites. Witnesses the customer representative mandrel pull and notifies the customer if Passed or Failed the inspection. Upon approval, the customer will pour a slurry of concrete 1/2 inch thick inside the transformer pad opening, for rodent protection.</p>
<p><u>Step 19</u>-Customer digs the service trench, installs the remaining service conduit system and the service meter panel. Customer calls Service Provider for service inspection if service is over 200A and/or a manufactured home. Customer must also call the governmental agency for inspection, refer to SR-101 for contact information.</p>	<p><u>Step 20</u>-Service Provider's representative inspects the service entrance and conduit system (if required) and notifies the customer if Passed or Failed the inspection. Governmental agency inspection must be completed and will notify Service Provider of final clearance.</p>
	<p><u>Step 21</u>-Service Provider will install the service & meter <u>AFTER</u> the final clearance has been received from the governmental agency & credit is cleared on the customers billing account. <u>Note</u>: Work loads and emergency power restorations may impact the installation date.</p>

FORMERLY SR-1.15

 	INITIATED BY	SC	REVISION NO.	8	SR-109  Pg. 1 of 2
	ESR COMM.	9-06	ESR COMM.	9-18	
			EFFECTIVE DATE	9-18	



Commercial Underground Project Outline

Customer Responsibilities	Service Provider Responsibilities
<p><u>Step 1</u>-Customer contacts Company's Design Services Department, refer to SR-101 for contact information. Customer provides the following:</p> <ol style="list-style-type: none"> 1) Residential New Construction Application information 2) Site plan if (1) acre or larger, and legal description of the property 3) Electric load plan if over 200 amps 4) Electrical Permit Number 	<p><u>Step 2</u>-Design Services reviews the plans and provide a Preliminary Electrical Design drawing for the customer within 20 days (if necessary). The Preliminary Electrical Design will include the Electrical Service Requirements specifications, easement requirements (if required) and the need for a contract and/or costs for the project (if required)</p>
<p><u>Step 4</u>-Customer approves or requests changes of the Preliminary Electrical Design. Customer signs the approval letter & faxes it to the assigned Scheduling Coordinator (if one is sent to the customer).</p>	<p><u>Step 3</u>-An Approval Letter is mailed to the customer by Design Services. This correspondence will include the Preliminary Electrical Design Drawing, related Electrical Service Requirements, and the request for a legal description and sketch for the new easement (if required).</p>
<p><u>Step 6</u>-If required, customer submits the original copies of the legal description and sketch written by a Registered Land Surveyor (RLS).</p>	<p><u>Step 5</u>-Design Services prepares a final Construction Drawing of the electrical system. Copies are sent to the customer and other utilities (<u>not all utilities receive copies</u>, customer to inquire with each utility) within 20 days.</p>
<p><u>Step 8</u>-Customer signs, notarizes the easement and returns to Service Provider.</p>	<p><u>Step 7</u>-Design Services forwards the legal description & sketch to Company Land Department to review & prepare for the customer's signature. The prepared easement package is sent to the customer within 20 days.</p>
<p><u>Step 10</u>-Customer executes the agreement and returns it to Service Provider, if required.</p>	<p><u>Step 9</u>-Design Services prepares any required Billable estimates. The Company sends the agreement to the customer. (i.e. Line Extensions, Prior to Improvements, etc.)</p>
<p><u>Step 12</u>-Customer makes service application and provides the electrical permit number and clears credit on the billing account.</p>	<p><u>Step 11</u>-Design Services sends the "Approved for Construction Drawing" and correspondence letter <u>AFTER</u> the easements and/or Agreements are received.</p>
<p><u>Step 13</u>-Customer may contact Design Services prior to starting construction, either by phone (to answer any questions) or an on site pre-construction meeting (if required).</p>	<p><u>Step 15</u>-Service Provider's representative inspects the civil work per Step 14 and notifies the customer if Passed or Failed the inspection. <u>NOTE:</u> For three-phase & single-phase projects, if executed easements are not returned at this point, courtesy inspections can be given up to the point of pulling a mandrel through the conduit system.</p>
<p><u>Step 14</u>-Stakes out easement for trenching contractor and Service Provider's inspector. For three-phase commercial projects:</p> <ul style="list-style-type: none"> • Trenches and installs duct and all sweeps plus 10 ft. riser section. Calls for inspection before concrete encasement. • Encases sweeps with concrete as needed. Calls for inspection before and after concrete encasement. • Backfills trench and installs pad. (If pouring pad, calls for framing inspection before pouring). • Installs bumper posts if required. Calls for inspection. • Installs pull rope in conduit system and calls for mandrel inspection. Mandrel will be pulled through the conduit system in the presence of a Service Provider's inspector. If necessary, calls 918-8300 for access into existing Company equipment. <p><u>NOTE:</u> Refer to Service Provider's construction drawing for all required specifications for pull box, PMH, PME and J-2 installation.</p>	<p><u>Step 16</u>-Design Services releases the job to construction once all the civil work is inspected and approved.</p>
<p><u>Step 18</u>-Customer installs service entrance, pulls in service conductors, color code tape ID the conductors and install an address label on each neutral conductor (for three-phase installations). If single-phase installation, install the service entrance and conduit system (in preparation for Service Provider cable installation). Calls Service Provider for trench, conduit, backfill and mandrel inspections.</p>	<p><u>Step 17</u>-Service Provider's schedules work in Construction that installs primary cable facilities (transformer, J-2's, PME units, etc.). Estimated 15 working days to complete job (30 days for project with a feeder system). <u>NOTE:</u> If a planned power outage is required to schedule the job, then Service Provider will coordinate the outage. The job will be completed when the outage can be scheduled.</p>
<p><u>Step 19</u>-Customer digs the service trench, installs the remaining service conduit system and service meter panel. Customer calls Service Provider for service inspection if service is over 200A and/or a manufactured home. Customer must also call the governmental agency for inspection, refer to SR-101 for contact information.</p>	<p><u>Step 20</u>-Service Provider taps the customer's wires at the transformer (if three-phase commercial) and sets meter. If single-phase, Service Provider installs service cable & sets meter. However, the following contingencies must be met:</p> <ul style="list-style-type: none"> • All Service Provider inspections passed. • Customer's credit clears. • Final governmental clearance received.

FORMERLY SR-1.16

	INITIATED BY	SC	REVISION NO.	10	SR-109 Pg. 2 of 2
	ESR COMM.	11-98	ESR COMM.	9-18	
			EFFECTIVE DATE	9-18	

ADDITIONAL INFORMATION

Codes and Regulations

The standards herein are supplementary to, and are not intended to conflict with the rate tariffs of the Company on file with Arizona Corporation Commission, the National Electrical Code as approved by the American National Standards Institute, the National Electrical Safety Code, the Uniform Administrative Code, the Uniform Building Code, the Mobile Home Manufacturers Association Standards for Mobile Homes, and such state, county, and other governing authorities' laws, codes, ordinances, orders, and statues as may be enforced within the cities, town, or areas to which the Company furnishes service.

Customer Installation

The customer shall install and maintain all wiring and equipment beyond the point of delivery, except for meter and special equipment installed by Service Provider. The customer's entire installation must conform to all applicable governmental codes and to accepted modern standards; and, if an affidavit or certificate of inspection or permit is required by law, or by Service Provider, the same must be furnished by the customer. In all cases, except for three-phase underground services and/or unless otherwise specified, "point of delivery" is the location on the customer's building, structure, or premises where all wires, conductors, or other current-carrying devices of the customer join or connect with wires, conductors, or other current-carrying devices of Service Provider. For three-phase underground services the point of delivery will normally be the secondary terminals of a pad-mounted transformer. Location of the point of delivery shall be determined by Service Provider in conformity with its standards and specifications, rate schedules, and construction standards as they exist from time to time.

Access To Premises

The customer should give the duly authorized agents and employees of Service Provider, when properly identified, full and free access to the premises of the customer at all reasonable hours for the purpose of installing, inspecting, adjusting, repairing, maintaining, replacing, or removing any of Company's facilities on the premises of the customer or for any purpose incidental to the service supplied by Service Provider including emergency situations.



Employee Identification

Each employee whose duty requires access to the premises of the customer is furnished with an identification card bearing his or her photograph. The customer should deny admittance to anyone claiming to be an employee who refuses to display a properly approved identification card. Any uncertainty of identity or of purpose or any unreasonable number of calls should be reported to the Company immediately. Company employees may not demand or accept any compensation from a customer for service rendered in the line of duty. However, certain employees do collect money from customers for settlements of accounts due to the Company and of which the customer is already aware.

Protection of Company Property

The customer at all times shall protect the property of the Company on the premises of the customer and shall permit no person other than the employees, agents, and authorized contractors of the Company and other persons authorized by law to inspect, work on, open or otherwise handle the wires, meters, or other facilities of the Company. In case of loss or damage to the property of Service Providers as a result of any carelessness, neglect, or misuse by the customer, any member of his family, or his agents, servants, invitees, or employees, the customer shall, at the request of the company, pay to TEP/UES the cost of any necessary repairs or replacements of such facilities or the value of such facilities.

FORMERLY SR-1.17, 1.18, 1.19, & 1.24

		INITIATED BY	GC	REVISION NO.	3	SR-110  Pg. 1 of 2
		ESR COMM.	9-06	ESR COMM.	9-18	
				EFFECTIVE DATE	9-18	

ADDITIONAL INFORMATION

Customer's Equipment

The Company does not design, plan, install, or maintain the customer's wiring, electrical equipment, or other customer owned facilities.

Interruptions

Service Provider will use reasonable diligence to supply continuous distribution service to the customer, but does not guarantee such supply against irregularities or interruptions. Service Provider shall not be considered in default of its service agreement with the customer and shall not otherwise be liable for any damages occasioned by any irregularity or interruption of service. The customer shall be responsible for paying for and installing the necessary equipment to guard against high or low voltage or the loss of one phase in a three-phase system. The customer shall not operate the equipment in such a manner as to cause any unusual voltage fluctuations on or other disturbances to Company's system.

Defaults

Service Provider shall not be considered in default of its service agreement and shall not otherwise be liable as a result of any failure by Service Provider to perform any obligation, if prevented from fulfilling such obligations by reason of delivery delays, breakdown of or damage to facilities, acts of God or public enemy, strikes or other labor disturbances the Company or the customer, civil, military or governmental authority, or any cause beyond the control of the Service Provider.

Resale of Energy

Electric service supplied by the Company is for the exclusive use of the customer on the premises to which such service is delivered by Service Provider. The Company will not supply electric service for sub-metering and resale by the customer except in rental trailer parks as approved by the Arizona Corporation Commission.

Attachments To Company Facilities

Attachments of any kind or nature on Company poles or other equipment, without previous consent will not be permitted.



Energy Diversion

Bypassing Company's meter may be considered Energy Diversion under Arizona law and may subject the customer to criminal and/or civil damages. (Arizona Revised Statutes §13-1602, §13-1802, §40-492). Additionally, the individual will be subject to fees as approved by the Arizona Corporation Commission.

Un-metered Energy

Devices or attachments shall not be connected to Company's facilities in such a manner as to permit the use of un-metered energy, except with prior written consent of Service Provider.

FORMERLY SR-1.17, 1.18, 1.19, & 1.24

 	INITIATED BY	GC	REVISION NO.	2	SR-110  Pg. 2 of 2
	ESR COMM.	9-06	ESR COMM.	9-18	
			EFFECTIVE DATE	9-18	

200 SECTION CIVIL INSTALLATIONS

<u>TITLE</u>	<u>SR-No.</u>
<u>Installations</u>	
Duct and Concrete Installation	205
Tracer Wire Installation, 46kV Underground	206
Trench, Backfill	207
Site Preparation for Equipment Pads on Sloping Grades	208
Trenching, Conduit and Equipment Placement	209
Sleeve Installation	210
Trench and Duct Encasement, Drainageway Crossings	212
▶ Pedestal and Secondary Junction Box	214
Trenching 2.5", 4" & 6" Conduit Installation	215
Duct Stub Detail	218
Underground Riser, Customer Installed	220
Distribution Pullbox with Manhole	225
Pullbox 15kv with Lid (Reference Only)	226
Equipment Barrier, Protective	230
Transformer Box Pad, Single Phase	231
Excavation & Duct Placement for 3-Phase Fused Junction Cabinet (F2)	232
Transformer Pad Underground 3-Phase	233
Excavation & Duct Placement for 3-Phase Junction Cabinet (J2)	234
Excavation & Duct Placement for 1-Phase Junction Cabinet (J1)	235
Excavation & Duct Placement for Switchgear Box Pad (PME)	240
Excavation & Duct Placement for Pad-Mounted Capacitor	241
Excavation & Duct Placement for Gas Insulated Switchgear Box Pad (Vista)	242
Equipment at Grade in Open Air Alcove	243

DUCT AND CONCRETE INSTALLATION



DUCT INSTALLATION

Duct shall be installed per the manufacturer's recommendations and shall be properly connected with couplings and/or cement and aligned such that there are no sharp edges on the inside to damage the cable.

- Install 2 1/2 inch and 4 inch duct, as applicable, in accordance with SR-209, SR-215, SR-308, SR-308A, SR-309, SR-310 or SR-312.
- Install 6 inch duct in accordance with SR-215.
- Install proper duct plugs at each end of duct and on each duct.
- Installation of duct at Company equipment such as risers, box pads, transformers, pull boxes, etc. shall be done in accordance to the applicable SR Standard.
- The Company reserves the right to reject any ducts which show signs of environmental damage.
- Solvent cemented joints shall be made according to the manufacturer's recommendations, using cements meeting the requirements of ASTM D2564 for PVC duct.

DUCT RADIUS

- Horizontal and vertical direction changes in the duct at the coupling shall not exceed 5°.
- The minimum radius of bends depends on duct size and type of installation and shall be as specified in SR-215, SR-308 or SR-312.
- The total of all deflections at couplings and bends shall not exceed 360° in any continuous duct run between Company equipment.

INSPECTION

All duct systems shall be installed by the customer and the following inspections completed, as applicable, by Service Provider Design Services.

- Duct - Inspection completed after duct installation and prior to concrete encasement or trench backfill.
- Concrete Encasement - Inspection completed after duct inspection approval and upon completion of concrete encasement prior to any backfill.
- Backfill - After duct and/or concrete inspection and in accordance with SR-207.
- Mandrel - Customer shall install a polypropylene pull rope with a 5/16 inch minimum diameter in the duct system in preparation to pull a steel mandrel no more than 1/2 inch smaller than the inside diameter of the duct.

Design Services will be on-site during mandrel to observe mandrel pull performed by the customer.

- TEP will provide an appropriate length of footage calibrated mule tape to attach to the mandrel that must be pulled through the duct.
- UES Santa Cruz, the customer is required to provide an appropriate length of footage calibrated mule tape to attach to the mandrel that must be pulled through the duct.

The installed mule tape will be used by The Company for subsequent cable installation.

Failure to have required inspections at the proper time will result in a delay until the duct is uncovered for inspection and the mandrel is pulled in the presence of the Service Provider's inspector. The Company reserves the right to require the installation of locatable "Tone Tape" (ARNCO "Tone -Tape" Part Number WP 25 LC) in place of a polypropylene pull rope.

Only Service Provider personnel and authorized contractors working for The Company are permitted entry into company owned pad-mounted equipment. If access is required into pad-mounted equipment the customer must arrange to have qualified Service Provider employee on site while the work is performed. Arrangements must be made by calling 520-918-8300 (TEP) or 520-761-7951 (UES), a minimum of five working days in advance.



		INITIATED BY	SC	REVISION NO.	25	SR-205 Pg. 1 of 5
		ESR COMM.	1-70	ESR COMM.	6-23	
				EFFECTIVE DATE	6-23	

DUCT AND CONCRETE INSTALLATION



CONCRETE STRUCTURES

All concrete for structures shall meet the following requirements.

- Mixture shall be such that it will work readily without segregation and will provide a minimum strength of 3000 lbs. per square inch at 28-day test.
- Concrete shall conform to proper slump tests of not less than 2 inches nor more than 4 inches, using a standard 12 inch cone.
- Service Provider may request a copy of the concrete delivery invoice to verify the ordered formula strength of the concrete mix.
- The customer or his contractor shall furnish test cylinders as requested by Service Provider for the purpose of materials testing.
- Test cylinders must reach 75 percent of the 3000 lbs. PSI rating or equivalent 21-day curing period before any equipment will be installed.
- Concrete shall be reinforced with deformed billet steel conforming to ASTM A615, Grade 60 as shown on the appropriate SR drawing and shall be thoroughly worked around reinforcing steel and into corners of forms.
- Concrete surfaces or inner faces of structures shall be clean and smooth.
- Finished floor surfaces shall be steel troweled smooth and level.
- Edges must be chamfered.

CONCRETE DUCT ENCASEMENT AND CAPPING



All concrete for duct coverage and protection shall meet the following requirements.

- Mixture shall be such that it will work readily without segregation and will provide a minimum strength of 2000 lbs. per square inch at 28-day test. The customer or his contractor shall furnish documentation at request from the Service Provider for the purpose of material verification.
- Duct encased in concrete shall have a 3 inch minimum and 5 inch maximum encasement and/or cap as shown in the appropriate SR drawing.
- All 46kV circuits (pole riser and pullbox to pullbox) require (4) four, 6 inch ducts per circuit and will require red dyed concrete encasement and locatable tracer wire the entire underground run. For tracer wire requirements refer to SR-206.

SPARE DUCTS

The Company will not guarantee the condition of, or the responsibility for, any ducts installed by any contractor for future use in the installation of an underground distribution system. Service Provider will assist in locating ducts stubbed for future use and will accept responsibility and ownership at such time as cable has been installed in the conduit system and energized. For information pertaining to sleeves refer to SR-210.



		INITIATED BY	SC	REVISION NO.	27	SR-205 Pg. 2 of 5
		ESR COMM.	1-70	ESR COMM.	6-23	
				EFFECTIVE DATE	6-23	

DUCT AND CONCRETE INSTALLATION



2 1/2" APPROVED DUCT TYPES (CONDUIT TO BE PROVIDED BY CUSTOMER)

2 1/2" PVC CONDUIT (REQUIRES A CONCRETE CAP, SEE SR-209 AND SR-215)

Grey Polyvinyl Chloride (PVC) electrical grade, Schedule 40 conduit for direct burial installation.

- Conduit to be manufactured to NEMA TC-2 specification.
- Conduit shall be rated for direct burial and use with 90°C conductors
- All bends and sweeps shall be factory bent and meet the following:
 - a) 36" x 90° or 36" x 45° for vertical
 - b) 12 1/2' x 45° for horizontal

2 1/2" HDPE CONDUIT-"WAVE-RIB" OR "DURA LINE-SMOOTH OUT/RIBBED IN" FLEXIBLE CONTINUOUS CONDUIT (COILED/ REELED), ALSO FOR DIRECTIONAL BORING.

- Conduit shall be Schedule 40, solid red color on the interior and exterior, and have a ribbed interior.
- Conduit shall be rated for direct burial and use with 90°C conductors.
- Conduit approved for directional Boring when crossing under a road and a street cut is not permitted or desired. Conduit is approved for use on road crossings and for extended length (distances greater than road crossings) boring installations. The Company reserves the right to require the customer to provide a boring profile.

2 1/2" DB-120 CONDUIT

Service Installation ONLY Exception - DB-120 conduit will be allowed for STRAIGHT runs in service laterals, from transformer or pedestal to the meter, as long as the following requirements are met:

- Service length is 250' or less
- Total bends in the conduit run are 270° or less
- Connectors and sweeps are Grey PVC, Electrical Grade, Schedule 40 for direct burial installation and use with 90°C conductors.
- Meter panel is on the same side of the building as the Company transformer or pedestal, as specified by Design Services.

DB-120 conduit CAN NOT be utilized in a cross trench installation, refer to SR-304 for details.

CONDUIT INSTALLATION - VERTICAL ABOVE GRADE (Riser Installation)

2 1/2" CONDUIT SWEEPS

- Steel Sweep
2 1/2" x 36" x 90° sweep

CONDUIT INSTALLATION -VERTICAL INTO COMPANY EQUIPMENT

2 1/2" CONDUIT SWEEPS

- Grey Polyvinyl Chloride (PVC) electrical grade, Schedule 40 for direct burial installation
2 1/2" X 36" X 90° or 2 1/2" x 36" x 45° sweep



		INITIATED BY	SC	REVISION NO.	6	SR-205 Pg. 3 of 5
		ESR COMM.	1-70	ESR COMM.	6-23	
				EFFECTIVE DATE	6-23	

DUCT AND CONCRETE INSTALLATION



4" AND 6" APPROVED DUCT TYPES (CONDUIT TO BE PROVIDED BY CUSTOMER)

4" & 6" GREY POLYVINYL CHLORIDE (PVC)

- Electrical grade, Schedule 40 for direct burial installation.
- Conduit to be manufactured to NEMA TC-2 standards.
- Conduit shall be rated for direct burial and use with 90°C conductors



4" & 6" HDPE CONDUIT- DURA LINE COEXTRUDED

- Conduit shall be Schedule 40, solid red color on the interior and exterior.
- Conduit shall be rated for direct burial and use with 90°C conductors.
- Manufacturer Part Number - HDP400SCHE40SWREDREDNEMPTDSSLS
- Manufacturer SLII to SLII Connector Numbers - 20000245 (4") and 20000256 (6")

4" & 6" CONDUIT FOR DIRECTIONAL BORING

Conduit approved for directional Boring when crossing under a road and a street cut is not permitted or desired. Bore-Gard Trenchless Raceway is approved for use on road crossings and for extended length (distances greater than road crossings) boring installations. The Company reserves the right to require the customer to provide a boring profile.

Arnco or Dura-line (HDPE) SDR-13.5 (ASTM D-3035) (Standard lead time of 12 weeks, if conduit is not in stock Border States Electric).

- Conduit must have solid red interior and exterior

Bore-Gard Trenchless Raceway from Prime Conduit Inc. (Standard lead time of 6-8 weeks, if conduit is not in stock at Border States Electric).

- Manufacturer Part Number - BG440SP-020 (4") and BG640SP-020 (6"), grey in color.

CONDUIT INSTALLATION - VERTICAL ABOVE GRADE (Riser Installation)

4" & 6" CONDUIT SWEEPS

- Steel Sweep
4" x 36" x 90° sweep or 6" x 48" x 90° sweep

46kV POWER POLE ATTACHMENT

- Rigid Aluminum
6" x 48" x 90° sweep

CONDUIT INSTALLATION -VERTICAL INTO COMPANY EQUIPMENT

4" & 6" CONDUIT SWEEPS

- Grey Polyvinyl Chloride (PVC) electrical grade, Schedule 40 for direct burial installation
4" X 36" X 90° sweep
6" X 48" X 90° sweep
6" x 48" x 45° sweep



		INITIATED BY	SC	REVISION NO.	2	SR-205 Pg. 4 of 5
		ESR COMM.	1-70	ESR COMM.	6-23	
		ESR COMM.	1-70	EFFECTIVE DATE	6-23	

DUCT AND CONCRETE INSTALLATION



PVC/HDPE/STEEL STUB TO HDPE



PVC TO GALVANIZED STEEL (POLE RISER)

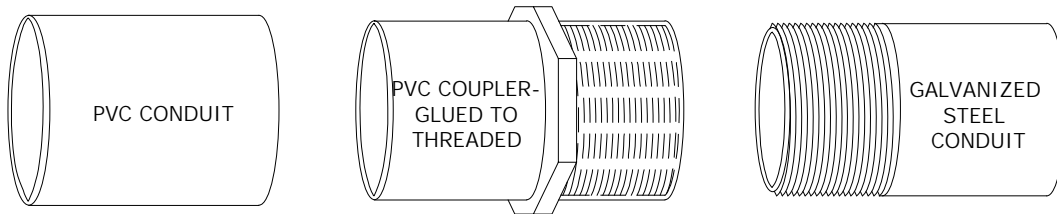

SMOOTH-COR STUB TO PVC/HDPE



ADDITIONAL PART NUMBERS FOR SMOOTH-COR:

- 4" KEYLOCKS - #400815
- 6" KEYLOCKS - #400831
- GASKET LUBE, QUART - #402813

ADAPTER PART NUMBER:

- 4" - #403555 OR #20000252
- 6" - #403574

GASKET SEAL PART NUMBER:

- 4" - #400816
- 6" - #400832

PVC TO PULL BOX END BELL

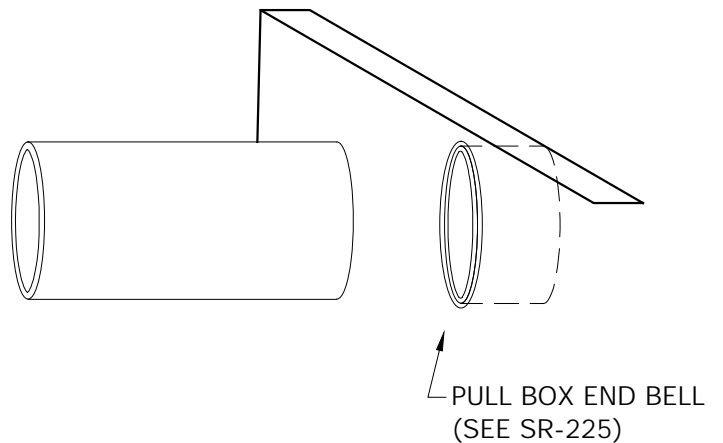

USE: Support line location of 46kV underground circuits.

TRACER WIRE INSTALLATION, 46kV UNDERGROUND

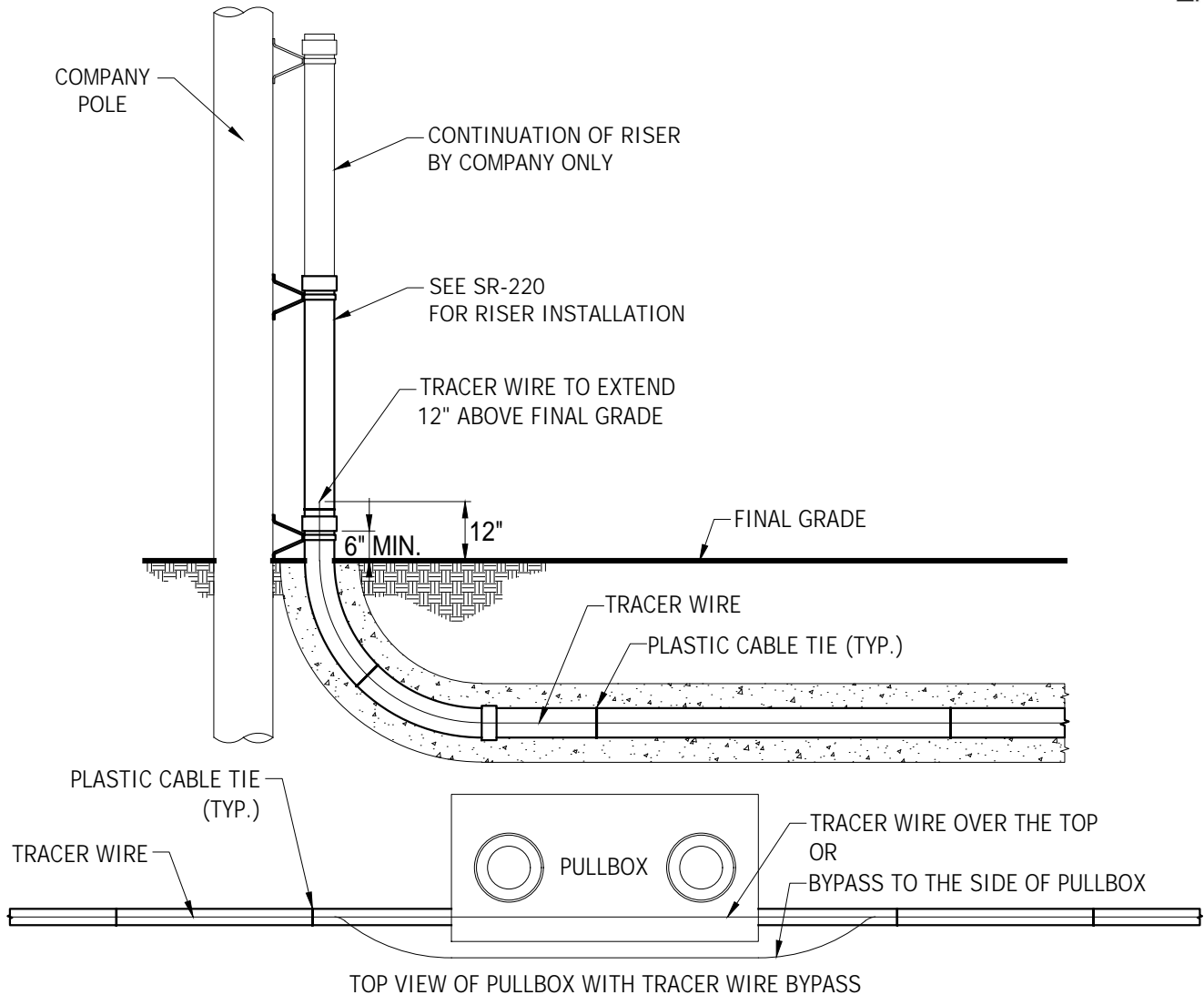

NOTES:

1. TRACER WIRE SHALL EXTEND 12 INCHES ABOVE FINAL GRADE AT ALL POLES OR EQUIPMENT LOCATIONS. TRACER WIRE SHALL BE TIED WITH PLASTIC CABLE TIES (ZIP TIE) ABOVE GRADE, MINIMUM OF ONE TIME ON SWEEP AND EVERY 15 FEET ALONG LENGTH OF RUN TO THE OUTSIDE OF THE CONDUIT, PRIOR TO CONCRETE ENCASEMENT AND BACKFILL.
2. CONTINUOUS RUN OF TRACER WIRE IS REQUIRED BETWEEN POLES AND SHOULD BY-PASS ANY PULLBOX EITHER TO THE SIDE OR OVER THE TOP.
3. CUSTOMER IS RESPONSIBLE FOR PROTECTION OF WIRE DURING BACKFILL. VERIFICATION OF WIRE FUNCTION WILL BE COMPLETED BY TEP UPON COMPLETION OF BACKFILL, PRIOR TO MANDREL PULL AND ACCEPTANCE OF CONDUIT.
4. SPLICING OF WIRE IS NOT ALLOWED, UNLESS LENGTH OF RUN EXCEEDS 2500 FEET. ANY SPLICE CONNECTION MUST BE SEALED AND RATED FOR DIRECT BURIAL, KING INNOVATION, DRYCONN WATERPROOF CONNECTORS (PART NO. 10444) OR EQUIVALENT.
5. TRACER WIRE SHALL BE #12 SOLID COPPER CONDUCTOR, INSULATED WITH RED HIGH MOLECULAR WEIGHT POLYETHYLENE (HMWPE), SUITABLE FOR CONTINUOUS SERVICE IN DIRECT BURIAL, WET AND DRY LOCATIONS. APPROVED WIRE, KRISTECH PE TRACER-12-RED-CU-HMWPE-600V-2500R (PART NO. 2663514) OR EQUIVALENT.
6. REFER TO SR-205 FOR CONCRETE REQUIREMENTS.

 TEP Tucson Electric Power	 UniSourceEnergy SERVICES SANTA CRUZ COUNTY	INITIATED BY	EKD	REVISION NO.	0	SR-206 Pg. 1 of 1
		ESR COMM.	11-22	ESR COMM.	-	
ESR COMM.	11-22	EFFECTIVE DATE	1-23			

Use: Acceptable soil conditions for cable bedding.

TRENCH, BACKFILL



SCOPE

This Standard outlines the acceptable soil and rock mixtures that may be utilized to provide bedding and trench backfill over and around TEP/UES installed primary, secondary, and service cables in polyethylene coilable duct (cable in conduit) and HDPE or PVC duct. For this discussion, "bedding" is defined as the soil mixture surrounding the duct, 6" on top and 3" on sides. "Backfill" is defined as the remaining soil mixture required to fill the trench excavation.

SPECIFICATION

All "bedding" material shall pass the following gradation:

Sieve Size	Percentage Passing Sieve	Plastic Index
1.5"	100	Max. 8
1"	90-100	
No. 8	35-80	
No. 200	0-8	

Should the existing soil conditions not meet this condition, then material meeting this requirement shall be imported for use in bedding of the cable in duct. Backfill is the material placed on top of the bedding starting a minimum of 6" above the duct. Bedding is the material in which the cable in duct is placed and extends a minimum of 6" above and 3" to the side of the duct. When imported bedding is required, the trench shall be overexcavated so as to provide a minimum of 6" of bedding under the duct and maintain the proper depth requirements for the cable in duct.

In either case, the trench floor shall be relatively smooth, with no loose or protruding rock and/or organic material (cactus, roots, boards, etc.).

From the point 6" above the duct where the bedding ends, the trench may be backfilled with excavated material, provided there are no rocks larger than 8" in any dimension be allowed in the trench. All backfill shall be compacted to meet or exceed local ordinances or other requirements. In no case shall compaction be less than the 95% relative to a Standard Proctor Density (ASTM D698). It shall be placed in a manner that will not damage the conduit or its substructure or allow future subsidence of the trench or substructure.

TEP/UES reserves the right to require density (compaction) testing to verify conformance with the above referenced standard. If required, density (compaction) testing shall commence approximately two feet above the top of the conduit or duct and continue to the base of the roadway structural section or the easement surface, as applicable. At a minimum of each reach of conduit or duct installed, one density test shall be taken at every two feet of vertical height of trench backfill between pull-boxes between pull-boxes or other structures, or one every 300 feet, whichever is shorter.

Company inspectors do not verify grade stakes. Any adjustments required to grade and/or pad sites due to inaccurate grading, grade changes and/or improper grade establishment at trench or pad sites will be the responsibility of the Developer/Contractor. Any associate costs to correct grade or pad sites and any costs incurred by Service Provider due to a change in surface elevation will be borne by the customer.



SITE PREPARATION FOR EQUIPMENT AND PADS ON SLOPING GRADES



SCOPE:

The intent of this standard is twofold; first, to provide a clear and level work space for the operation and maintenance of pad-mounted equipment, and second, to prevent erosion and soil deposition problems when pad-mounted equipment is placed on sloping grades. This standard applies to the site preparation for the following; single and three-phase Transformers, Pedestals, J10, J30, J1, J2, J6 and F2 cabinets, PMH/PME/Vista Switchgears and Capacitors.

OPERATING WORK AREA:

A 10 foot permanent clear work area is required in front of the pad-mounted equipment for hot-stick operation. An effort should be made to keep this 10 foot area to a flat grade. If this is not possible the grade shall be no greater than a 12 inch vertical rise to a 9 foot (drop 4 inches in 3 feet) horizontal run. (See FIGURE 1)

REQUIREMENTS FOR RETAINING WALLS:

Where the slope of the land adjacent to the sides and rear of the easement area is greater than a 12 inch vertical rise to a 3 foot horizontal run a retaining wall shall be constructed to prevent erosion or soil deposition. Walls are to be located outside of the easement. (See FIGURE 1 through FIGURE 7). Refer to SR-108 for easement requirements.



REQUIREMENTS FOR SCREEN WALLS:

The customer can place a screen wall around a transformer, provided the wall is kept outside of the easement for the transformer. A clear area, 10 feet deep, should be provided in front of the transformer door(s) to allow for a proper operating work area. A gate the width of the easement may be placed in front of the transformer to completely screen the transformer, providing all other clearance requirements are met. The gate is not to be locked, unless arrangements are made for a TEP lock with access. For three phase pad-mounted transformer the screen wall must be at least three feet away from any extending part of the transformer.

REQUIREMENTS FOR ESTABLISHMENT OF GRADE:

Company inspectors do not verify grade stakes. Any adjustments required to grade and/or pad sites due to inaccurate grading, grade changes and/or improper grade establishment at trench or pad sites will be the responsibility of the Developer/Contractor. Any associate costs to correct grade or pad sites and any costs incurred by Service Provider due to a change in surface elevation will be borne by the customer.

EASEMENT REQUIREMENTS:



Refer to Company issued construction drawing for project specific easements and required access. See SR-108 for details.

		INITIATED BY	DJ	REVISION NO.	16	SR-208 Pg. 1 of 2
		ESR COMM.	7-86	ESR COMM.	4-23	
				EFFECTIVE DATE	4-23	

SITE PREPARATION FOR EQUIPMENT AND PADS ON SLOPING GRADES



FIGURE 1

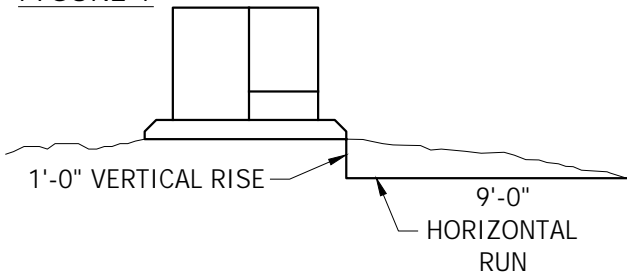

FIGURE 2

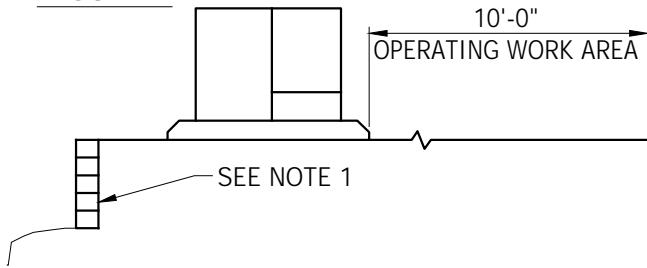

FIGURE 3

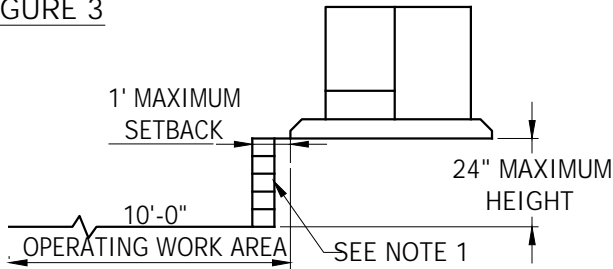

FIGURE 4

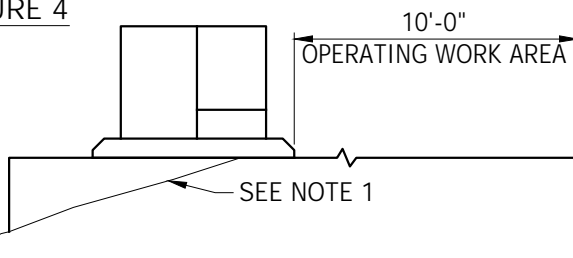

FIGURE 5

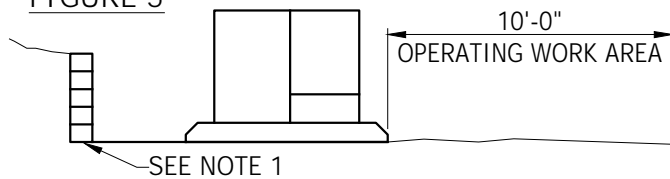

FIGURE 6
TRANSFORMER CLEARANCE

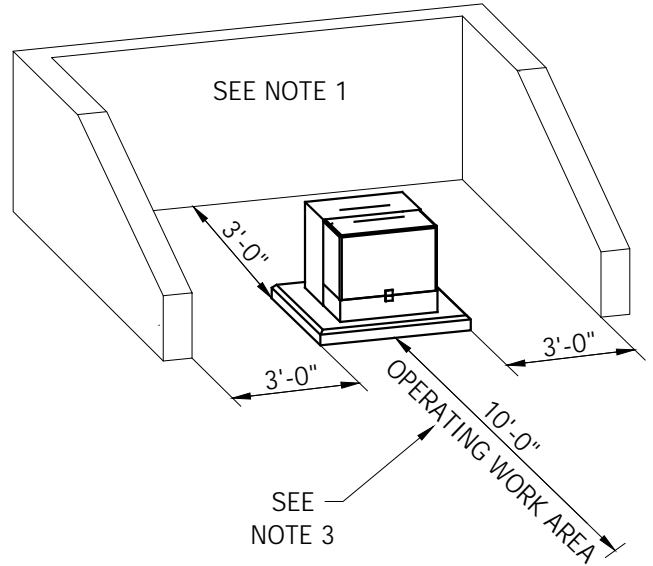
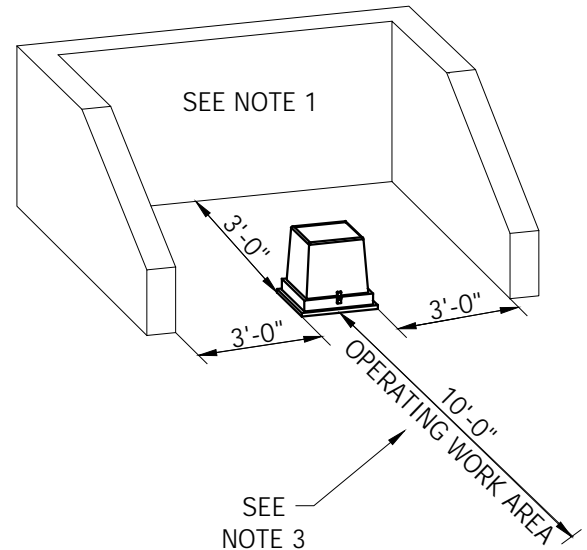

FIGURE 7
PEDESTAL, J10 OR J30 CLEARANCE



NOTES:

1. INSTALL RETAINING WALL (CONCRETE BLOCK/SOLID CONCRETE OR EQUIVALENT) AS NECESSARY.
2. THE AREA IN FRONT OF SINGLE-PHASE TRANSFORMER PADS MUST BE LEFT SUITABLE FOR THE FUTURE TRENCHING ACCESS REQUIRED FOR NEW SERVICES.
3. 10'-0" OPERATING WORK AREA NEEDED FROM ANY WALL OR OBSTRUCTION.



		INITIATED BY	DJ	REVISION NO.	10	SR-208
		ESR COMM.	7-86	ESR COMM.	4-23	
				EFFECTIVE DATE	4-23	



SERVICE PROVIDER ONLY

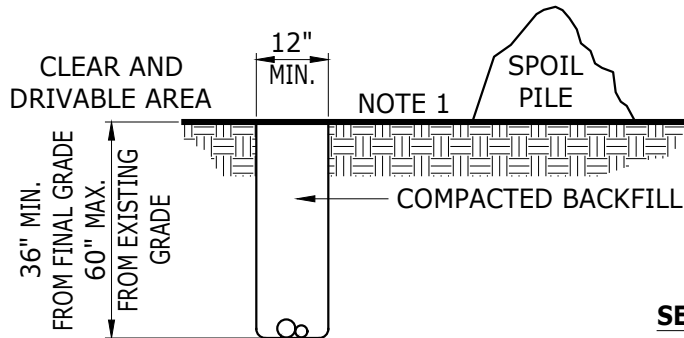

SERVICE PROVIDER
PRIMARY AND
SECONDARY CONDUIT

SERVICE PROVIDER WITH OTHER UTILITIES

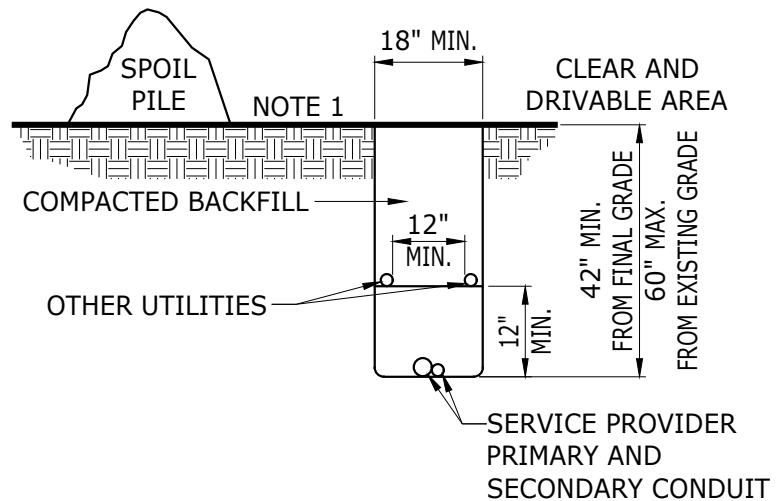

SECONDARY AND/OR SERVICE TRENCH

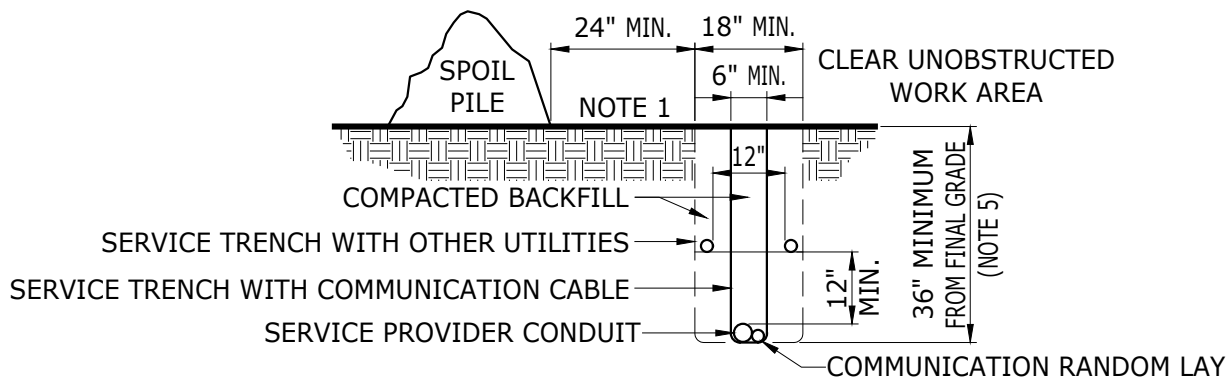

DRAWING NOTES:

INFORMATION IN THIS STANDARD IS PROVIDED TO PROMOTE AWARENESS OF LOCAL UTILITY COMPANIES CLEARANCE REQUIREMENTS. DIMENSIONS PROVIDED ARE TEP/UES REQUIREMENTS. CHECK WITH LOCAL UTILITY COMPANIES FOR SPECIFIC CLEARANCE REQUIREMENTS. WET UTILITIES TYPICALLY REQUIRE ADDITIONAL CLEARANCE FROM WHAT IS SHOWN.

		INITIATED BY	DS	REVISION NO.	22	
		ESR COMM.	6-78	ESR COMM.	7-25	
				EFFECTIVE DATE	7-25	



NOTES:

1. Where possible, the trench spoil shall be placed to the opposite side of the access to the trench. Adequate protection shall be provided to protect employees from loose rock or soil that could pose a hazard by falling or rolling into the excavation. Protection can be provided by placing and keeping such materials at least 2 feet from the edge of the excavation, or by other means that provide equivalent protection. This 2 feet area shall be level and free of debris to permit safe footing during inspection.
2. On-site inspections by Service Provider are required for open trench, bedding, and shading. Contact Design Services to schedule required inspections.
3. When modifying existing cable-in-conduit (CIC) installation, a 2 feet x 5 feet bell hole is required. Bell holes for service trenches must comply with the requirements of SR-312 and SR-210, where applicable.
4. The minimum horizontal radius in a trench prepared for installation of wave rib conduit system shall be 4 feet and a minimum horizontal radius of 12 feet 6 inches on a Schedule 40 PVC continuous conduit system.
5. Service trenches for the continuous conduit system must be 36 inches in depth.
6. Under no circumstances is a trench to be dug closer than 3 feet to a down guy anchor rod.
7. See SR-210 for sleeve installation where a trench can not remain open.
8. The service conduit shall be installed into the equipment sites at the same time as the primary and/or secondary conduits are installed. All conduits are to be tied up per the equipment detail, and prior to calling for the trench and conduit inspection.
9. Conduit sweeps into existing equipment shall be 2 1/2 inches x 36 inches x 90 degree, Grey PVC Electrical Grade, Schedule 40. Wave-rib conduit is NOT approved to be used in existing Company equipment.
10. Do not trench under Company owned pad-mounted equipment without Service Provider personnel present. Service Provider's Access Crew can be scheduled to assist with conduit placement and/or trenching required under Company owned equipment. Arrangements must be made by calling 520-918-8300 (TEP) or 520-761-7951 (UES), a minimum of five working days in advance.
11. See SR-207 for bedding and backfill requirements.
12. Company inspectors do not verify grade stakes. Any adjustments required to grade and/or pad sites due to inaccurate grading, grade changes and/or improper grade establishment at trench or pad sites will be the responsibility of the Developer/Contractor. Any associate costs to correct grade or pad sites and any costs incurred by Service Provider due to a change in surface elevation will be borne by the customer.
13. Refer to SR-108 for Right-of-way and Easement requirements.

		INITIATED BY	SC	REVISION NO.	19	SR-209	
		ESR COMM.	5-78	ESR COMM.	7-25		Pg. 2 of 10
				EFFECTIVE DATE	7-25		



OFFSET EASEMENT - TRANSFORMER

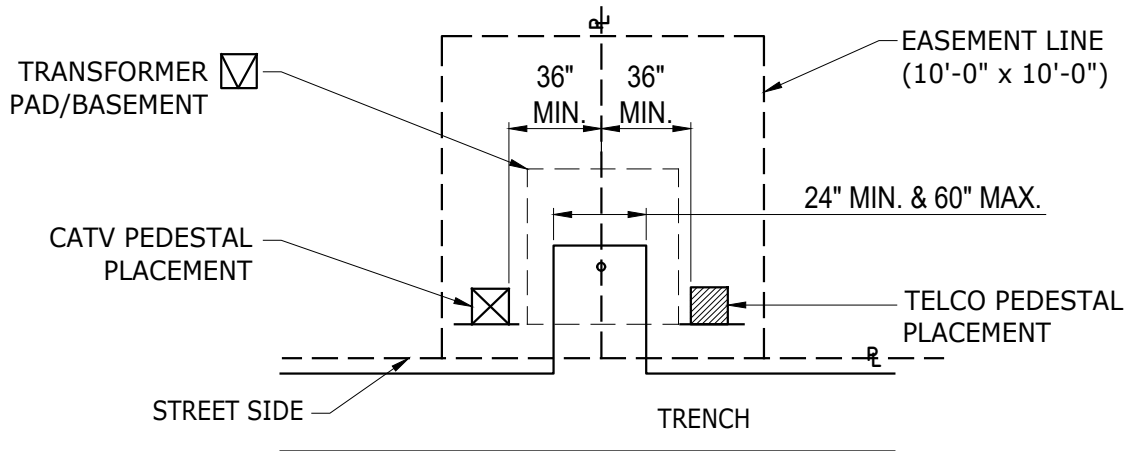

STRIP EASEMENT - TRANSFORMER

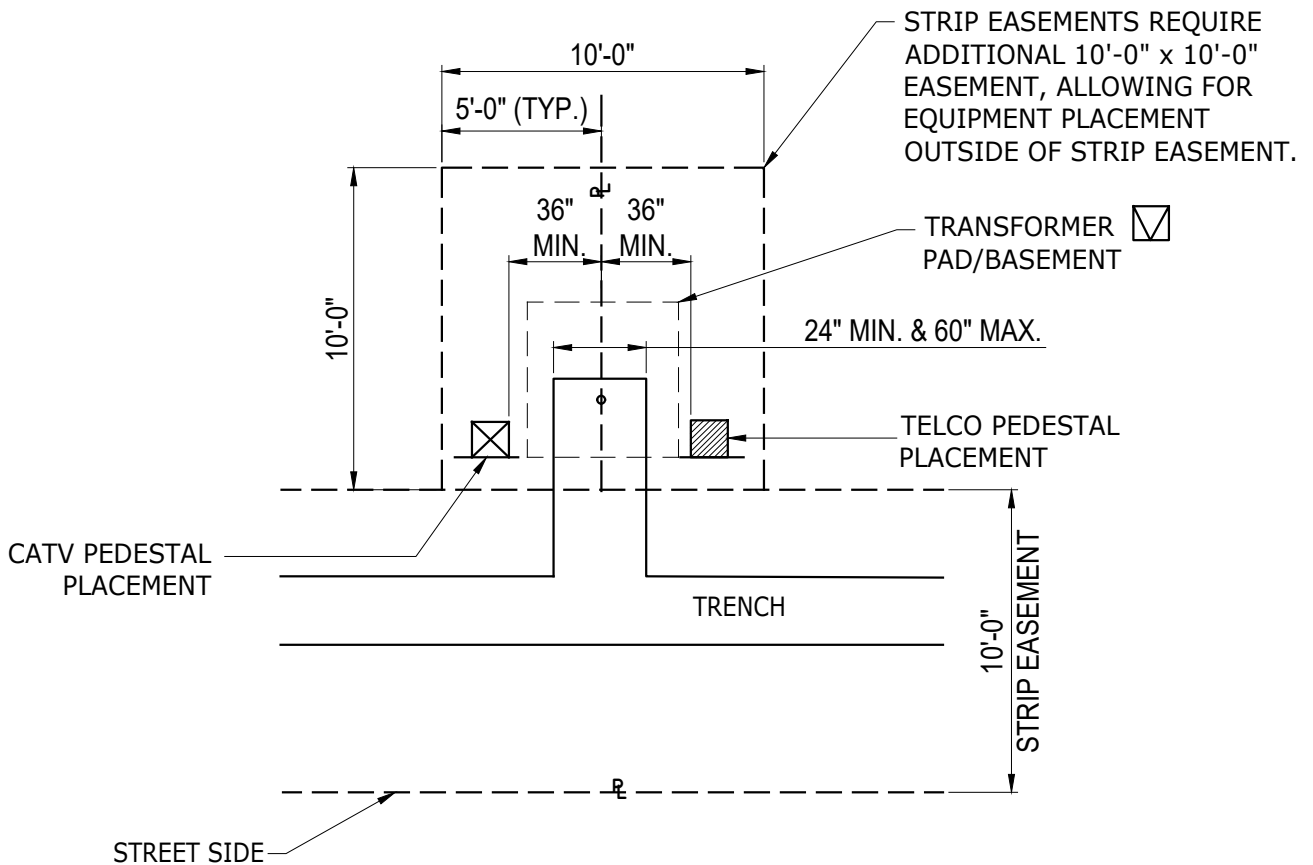



OFFSET EASEMENT - PEDESTAL

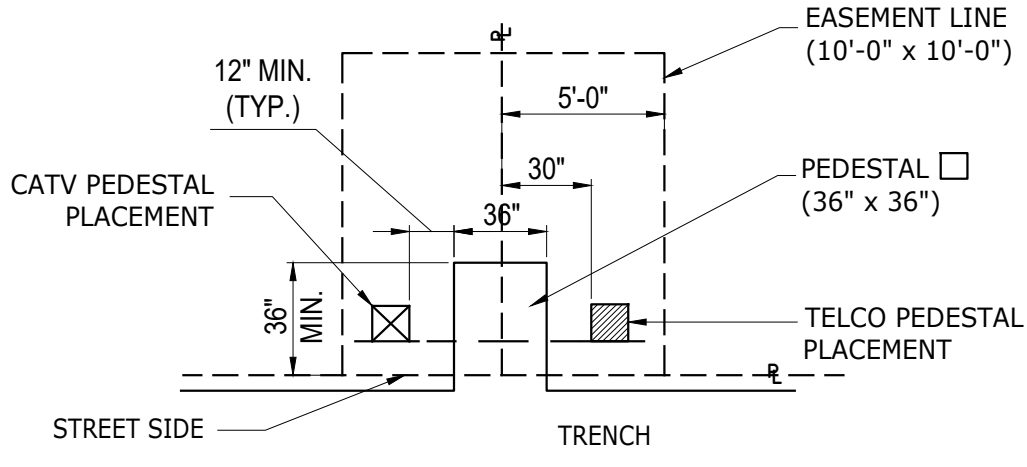

STRIP EASEMENT - PEDESTAL

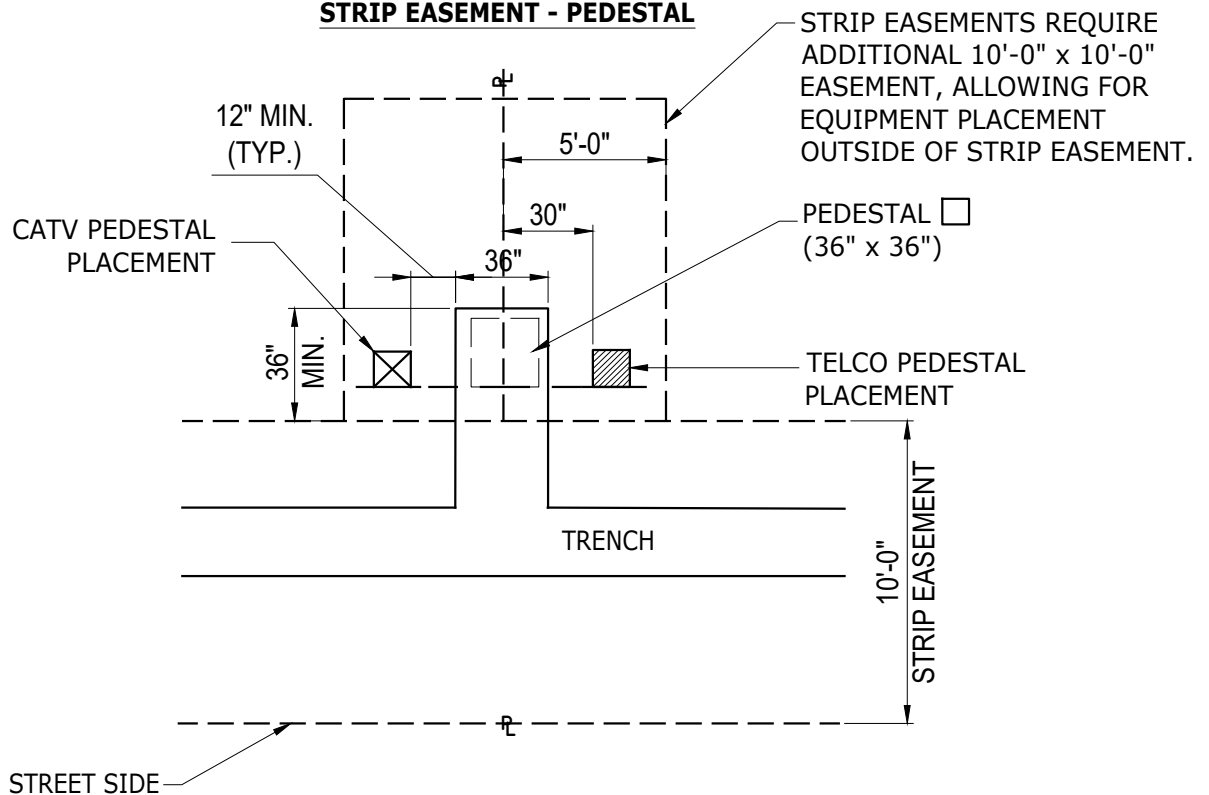

USE: EQUIPMENT
 PLACEMENT,
 SUBSURFACE
 SECONDARY
 JUNCTION BOX

TRENCHING, CONDUIT AND EQUIPMENT PLACEMENT



OFFSET EASEMENT - CUSTOMER PROVIDED SUBSURFACE SECONDARY JUNCTION BOX

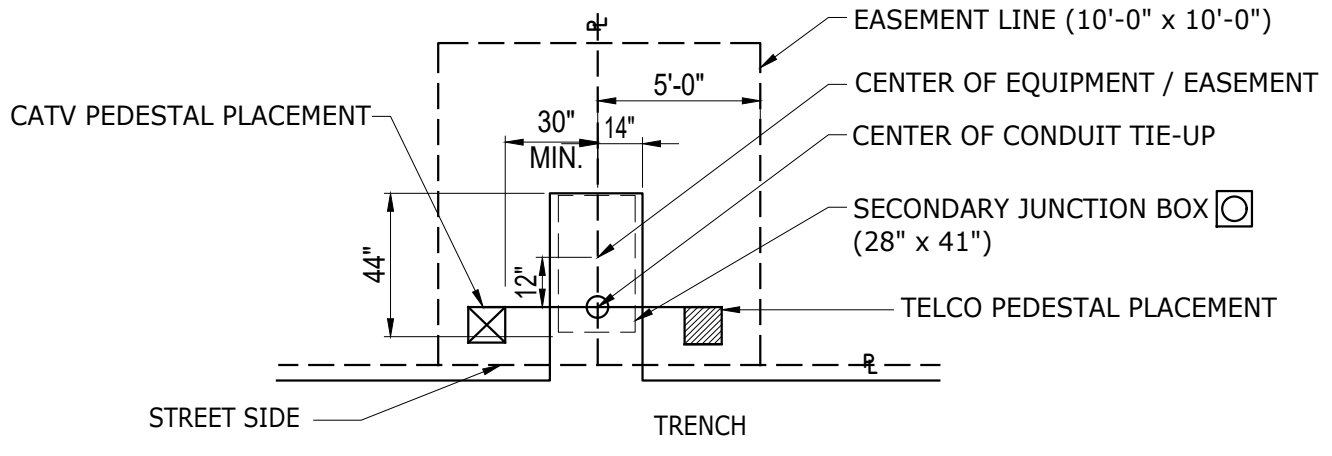

STRIP EASEMENT - CUSTOMER PROVIDED SUBSURFACE SECONDARY JUNCTION BOX

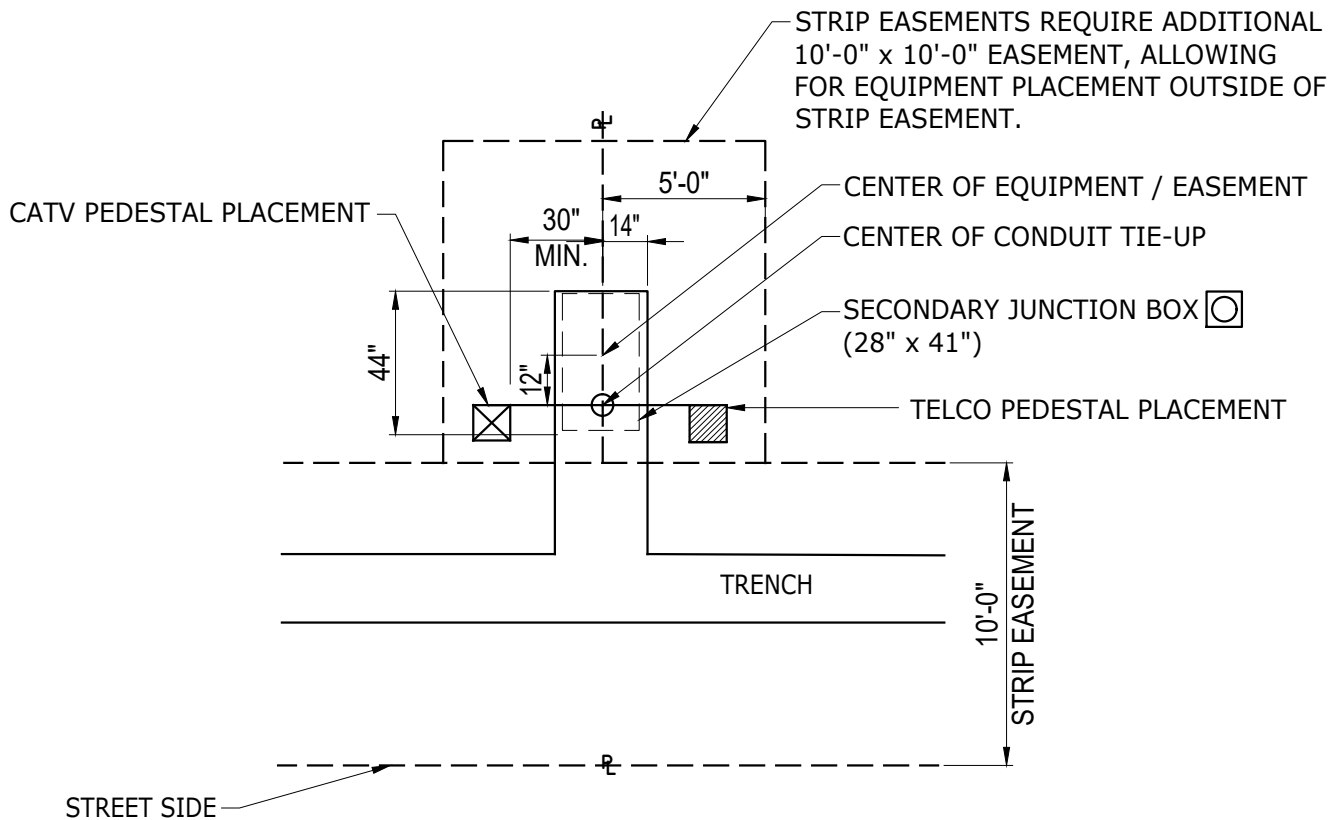



OFFSET EASEMENT - J-1 CABINET

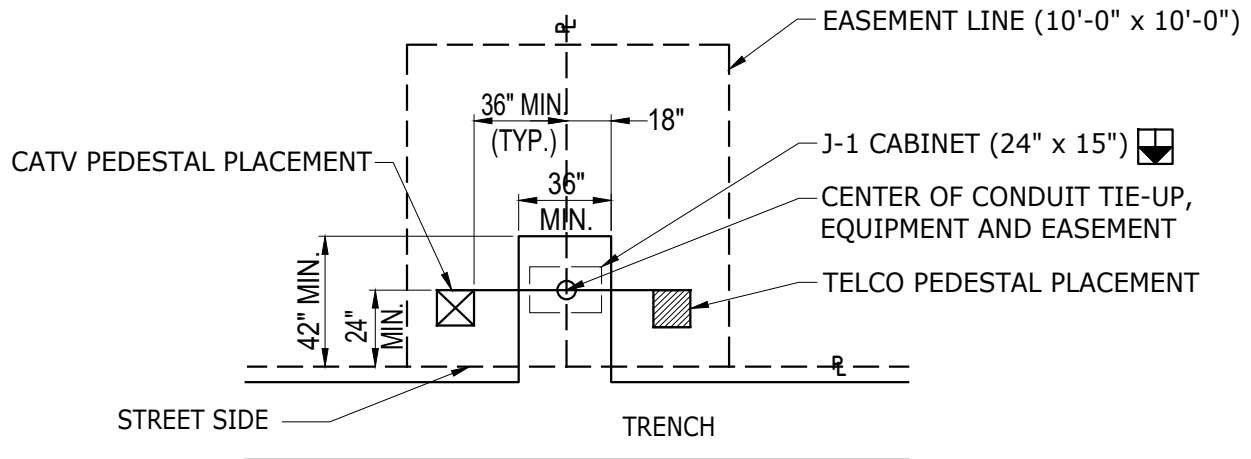

STRIP EASEMENT - J-1 CABINET

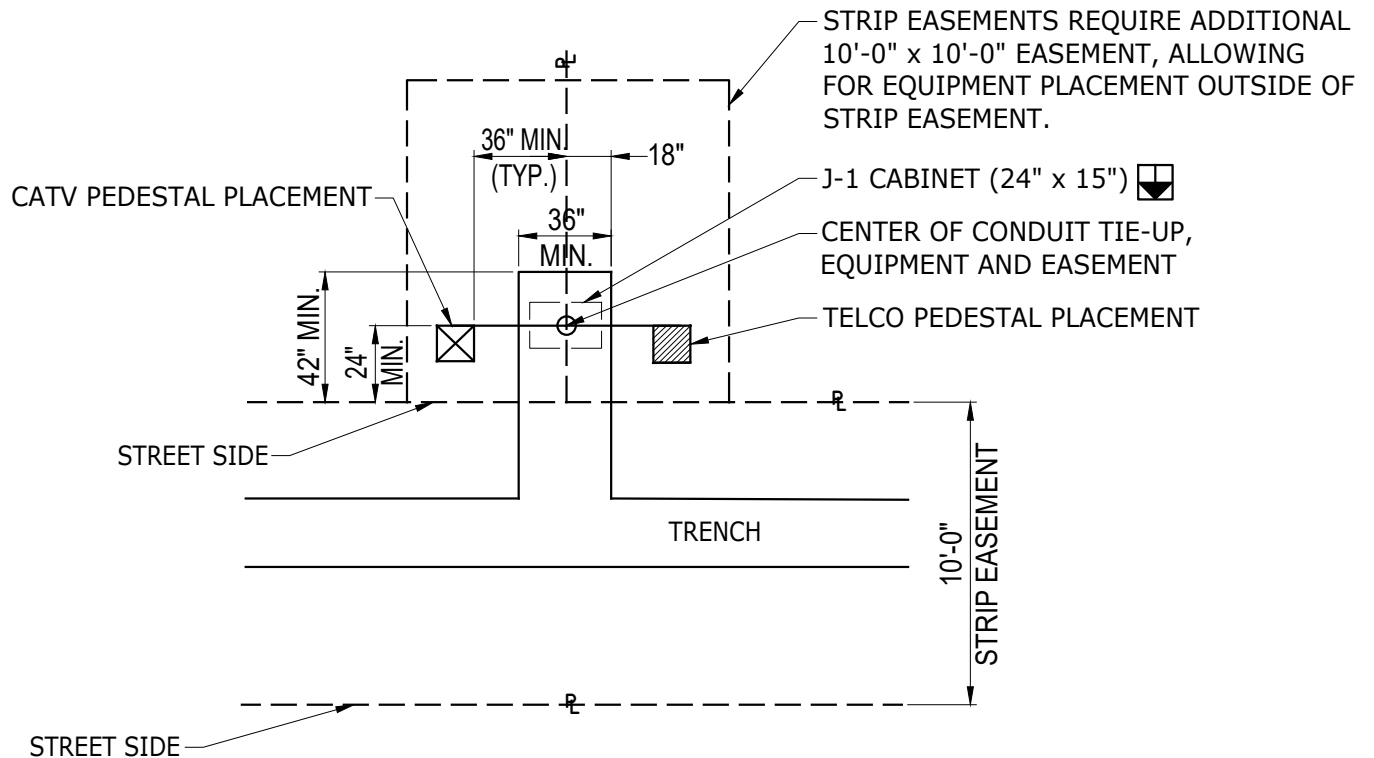

USE: TRANSFORMER PAD
CONDUIT PLACEMENT,
100-167kva
(TEP MAINTENANCE
AND TEMP. ONLY
25-75KVA)

TRENCHING, CONDUIT AND EQUIPMENT PLACEMENT



15

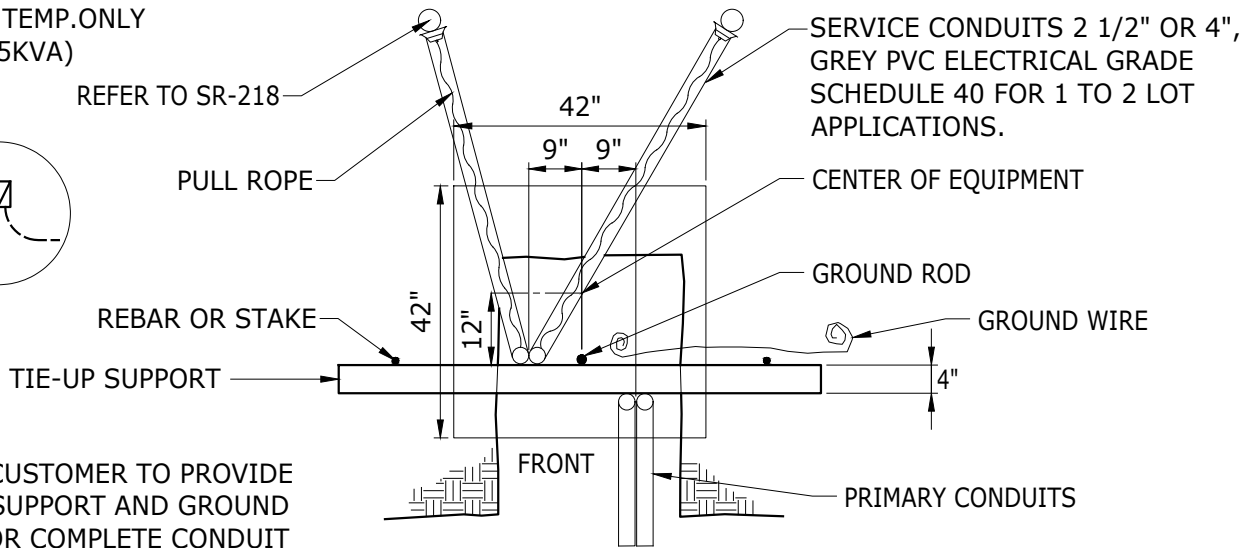
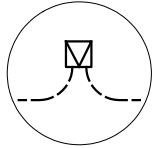

NOTE: CUSTOMER TO PROVIDE TIE-UP SUPPORT AND GROUND WIRE FOR COMPLETE CONDUIT INSTALLATIONS.

**PAD MOUNTED TRANSFORMER
PLAN VIEW**

2 1/2" x 36" x 90° AND 5'-0" STRAIGHT GREY PVC ELECTRICAL GRADE, SCHEDULE 40 CONDUIT IS TO BE USED FOR SERVICE STUB. THE STUBS ARE TO BE IN PLACE FOR THE PRIMARY TRENCH/CONDUIT INSPECTION.

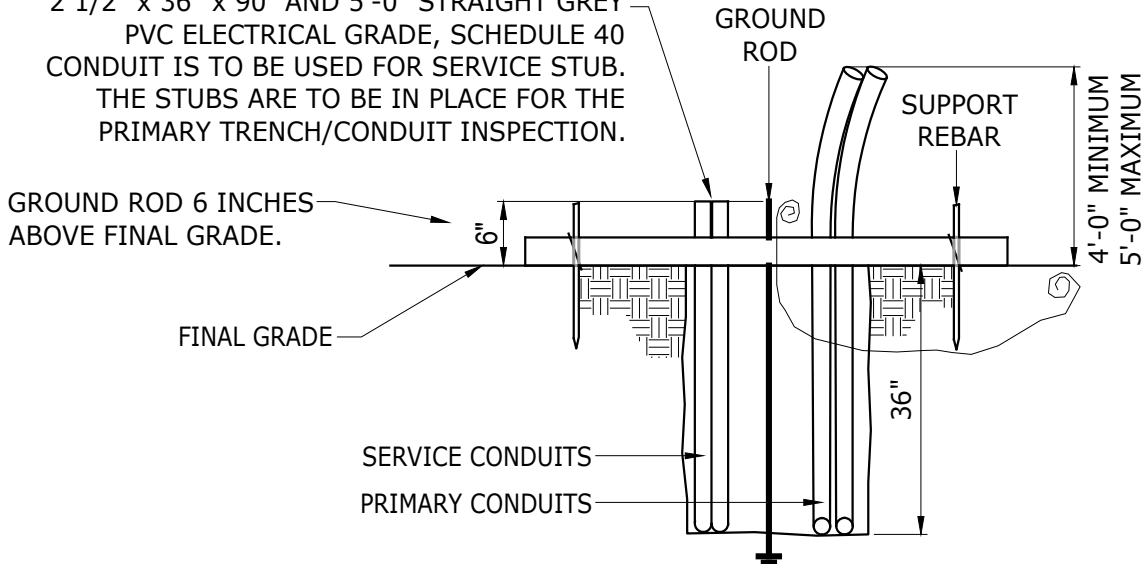

**PAD MOUNTED TRANSFORMER
FRONT VIEW**

NOTES:

- NEW EQUIPMENT SITES (ONLY)** - WHEN USING WAVE-RIB CONDUIT, LEAVE 4 TO 5 EXTRA FEET TO ASSIST WITH SHAPING AND HOLDING THE CONDUIT IN PLACE, DURING BACKFILL. CONDUIT SHOULD ONLY BE CUT AFTER BACKFILL INSPECTION IS COMPLETE AND APPROVED BY DESIGN SERVICES.
- EXISTING COMPANY EQUIPMENT** - CONDUIT SWEEPS INTO EXISTING EQUIPMENT SHALL BE 2 1/2" x 36" x 90 DEGREE, GREY PVC ELECTRICAL GRADE, SCHEDULE 40. WAVE-RIB CONDUIT IS NOT APPROVED FOR USE IN EXISTING EQUIPMENT. CONTACT TEP (520) 918-8300 OR UES (520) 761-7952, TO SCHEDULE AN ACCESS APPOINTMENT FOR ASSISTANCE WITH THE CONDUIT PLACEMENT.
- GROUND RODS** ARE NOT PERMITTED TO BE CUT UNDER ANY CIRCUMSTANCE. IF SOIL CONDITIONS PROHIBIT DRIVING THE GROUND ROD PER THE SERVICE REQUIREMENT, CONTACT DESIGN SERVICES.
- SEE SR-231 FOR TRANSFORMER TIE-UP DETAILS WHEN INSTALLING TRANSFORMER BOX PAD.**

USE: TRANSFORMER PAD
CONDUIT PLACEMENT,
100-167kva
(TEP MAINTENANCE
AND TEMP. ONLY
25-75KVA)



TRENCHING, CONDUIT AND EQUIPMENT PLACEMENT

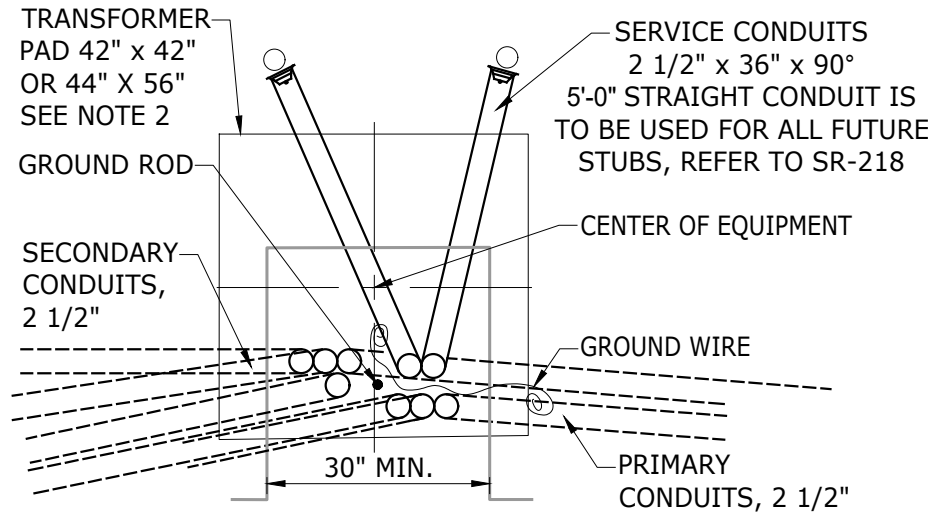

**PAD MOUNTED TRANSFORMER
PLAN VIEW - STRIP EASEMENT**

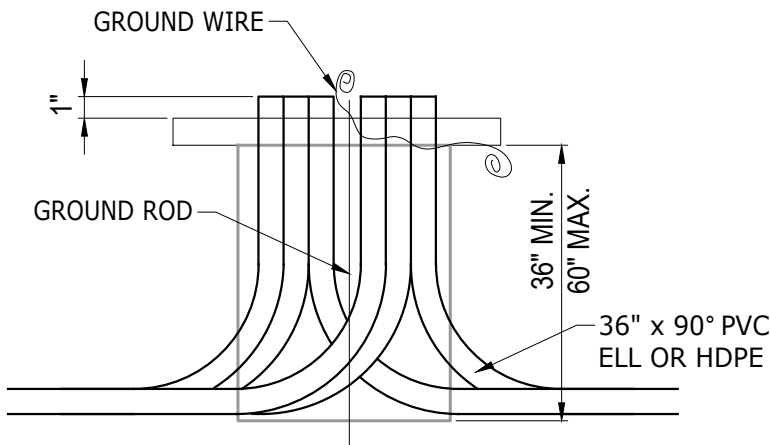

**PAD MOUNTED TRANSFORMER
FRONT VIEW - STRIP EASEMENT**

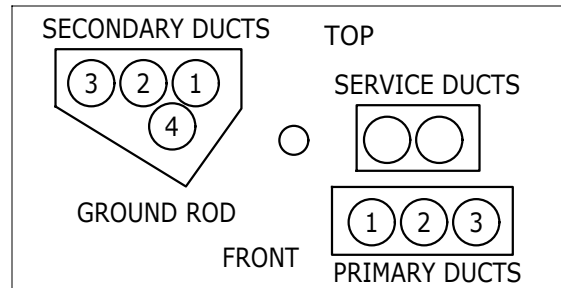

TRANSFORMER TEMPLATE

7-07-1002 - 1 OR 2 SERVICES
7-07-1001 - MULTIPLE SECONDARIES
OR SERVICES



NOTE:

1. GROUND RODS ARE NOT PERMITTED TO BE CUT UNDER ANY CIRCUMSTANCE. IF SOIL CONDITIONS PROHIBIT DRIVING THE GROUND ROD PER THE SERVICE REQUIREMENT, CONTACT DESIGN SERVICES.
2. LARGER TRANSFORMER PAD (44 X 56) IS USED FOR 100KVA TRANSFORMERS AND LARGER, SMALLER PAD (42 X 42) IS USED FOR TEP MAINTENANCE ONLY.
3. **SEE SR-231 FOR TRANSFORMER TIE-UP DETAILS WHEN INSTALLING TRANSFORMER BOX PAD.**

TRENCHING, CONDUIT AND EQUIPMENT PLACEMENT

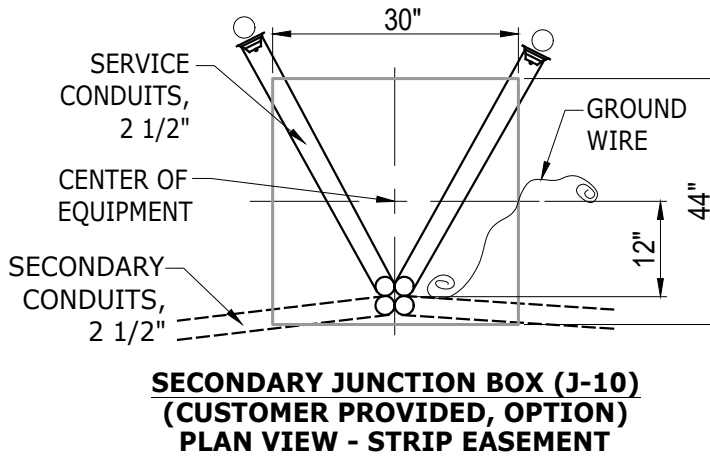
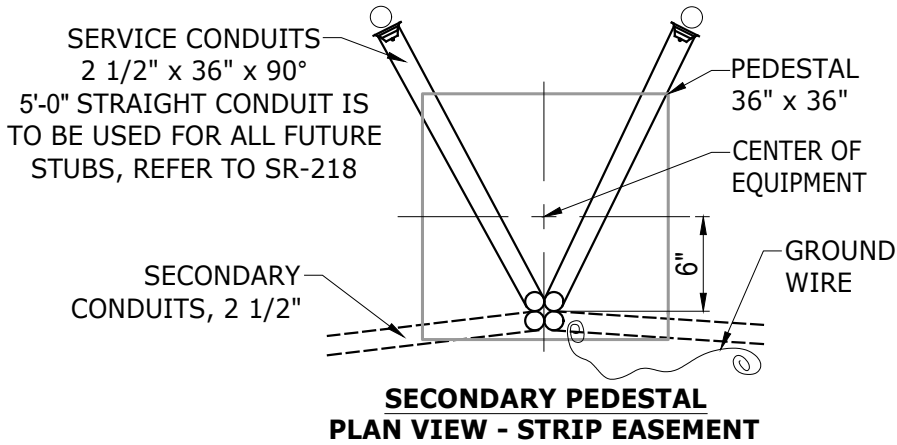

NOTE:

1. FOR APPROVED MANUFACTURERS OF SECONDARY JUNCTION BOX (J-10), REFER TO SR-308, FIGURE 1.
2. FOR PEDESTAL AND SECONDARY JUNCTION BOX INSTALL, REFER TO SR-214



TRENCHING, CONDUIT AND EQUIPMENT PLACEMENT



NOTES:

EASEMENT/EQUIPMENT IDENTIFICATION

1. Customer is to provide property pins and/or swing ties (stakes) to the center of equipment at the equipment (transformer, pedestal, J-10, J-1, J-2, etc.) location. These pins/stakes must be in place for the trench/conduit and backfill/mandrel inspections.

CONDUIT PLACEMENT / TRANSFORMER PAD SITE PREPARATION (See SR-231 for box pad)

2. Pad and trench sites shall be level and at final grade before calling Design Services for a trench/duct inspection. Driven ground rod to be 6 inches above final grade. Ground Rods are Not Permitted to be cut under any circumstance. If soil conditions prohibit driving the ground rod per the SR, contact Design Services.
3. Customer to utilize an approved conduit template available for purchase from Design Services, during the backfill process to ensure proper conduit and ground rod placement at final grade. Duct plugs are required for all conduits, use of duct tape to close ducts is not approved.
4. After the conduits (SR-205) and ground rods are in place, the customer is to install a #6 solid soft drawn copper conductor for Telco bonding from the ground rod 2 feet above the pad (at the ground rod), 12 inches away from the front of the pad and 36 inches to the right of the pad site. Bury the conductor 12 inches below final grade and coil up approximately 2 feet of conductor. With the template in place, pour concrete on the conduit if using PVC, per SR-205 and 215 and call for an inspection. Upon passing the inspection, backfill and compact to 95 percent, level the equipment site and install the transformer pad. The conduit shall be cut 1 inch above the top of the pad and covered with the appropriate duct plug. See SR-208 for equipment site preparations, including sites with slopes.
5. The customer to call for a transformer pad site, pedestal site, and mandrel inspection, upon approval the customer will pour 1/2 inch mortar slurry mix in the pad opening for rodent protection.

PEDESTAL SITES



6. The Company will provide the pedestal. The customer is to excavate and install per SR-214. After the conduits (SR-205) are in place, the customer is to install a #6 solid soft drawn copper conductor for Telco bonding from 2 feet above the sub grade (next to the right side of the conduits), 12 inches away from the front of the pedestal and 24 inches to the right of the equipment site. Bury the conductor 12 inches below final grade and coil up approximately 2 feet of conductor.

SECONDARY JUNCTION BOX SITES, J-10 (CUSTOMER PROVIDED IN PLACE OF PEDESTALS)



7. The customer to provide and install the 20K rated J-10 box, per SR-214. Install ground wire per Note 6 on this page.

JUNCTION CABINET SITES, J-1 AND J-2

8. The Company will provide the subsurface base. The customer is to excavate and install per SR-235 (J-1) or SR-234 (J-2). For J-1, install ground wire per Note 6 on this page.

COMPANY FURNISHED EQUIPMENT

9. The Company will furnish the transformer pads, pedestals, and ground rods at the customers' request. A two week noticed is needed to allow for scheduling. A site contact name, phone number and location of material staging area needs to be provided when making arrangements for delivery. A signature will be required upon delivery. It is the customers' responsibility for the care of the material. Any lost, or damaged material will be the responsibility of the customer to replace with Company approved material.

		INITIATED BY	EKD	REVISION NO.	4	SR-209	
		ESR COMM.	9-20	ESR COMM.	7-25		Pg. 10 of 10
				EFFECTIVE DATE	7-25		

USE: SLEEVE WHEN TRENCH CAN NOT REMAIN OPEN. MUST BE COMPLETED AS CONTINUOUS DUCT SYSTEM.

SLEEVE INSTALLATION

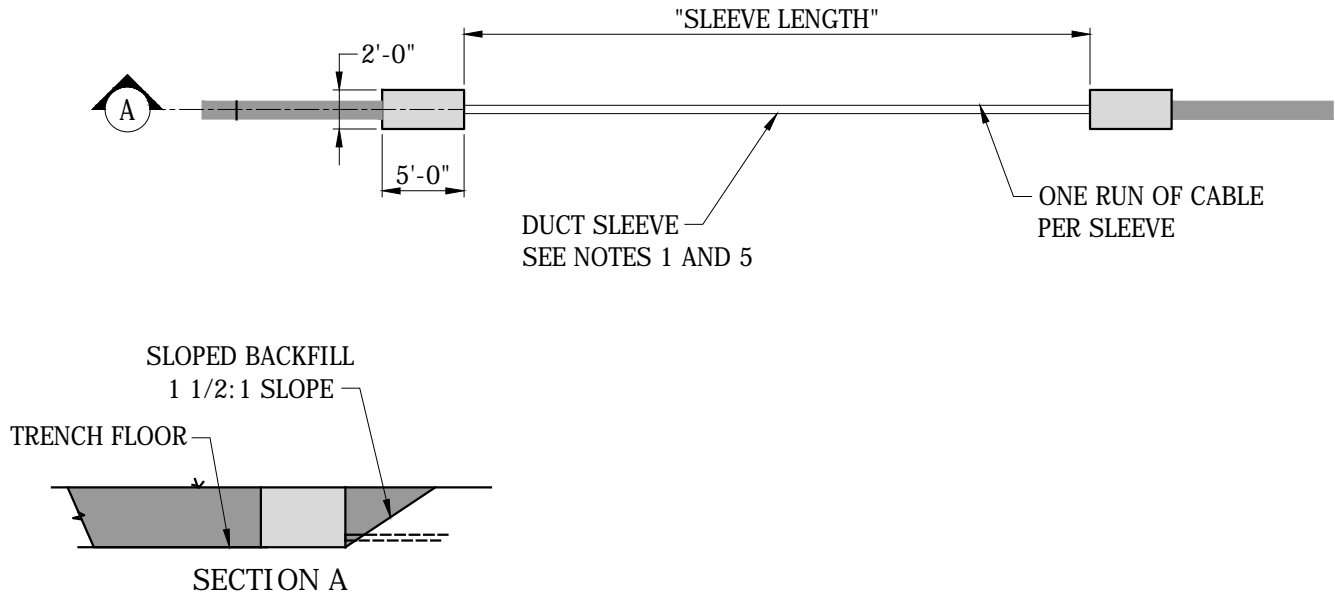

NOTES:

1. WHERE A DUCT SYSTEM IS INSTALLED UNDER ROADS, DRIVEWAYS, DRAINAGEWAYS, ETC. FOR THE PURPOSE OF CABLE INSTALLATION, A 2 FT. X 5 FT. BELL HOLE MUST BE DUG AT EACH END OF THE DUCT TO ALLOW FOR COMPANY INSPECTION. THERE IS TO BE NO BENDING RADIUS IN THE DUCT SLEEVE.
2. OPEN ENDS OF DUCT SHALL BE PLUGGED, WITH AN APPROVED DUCT PLUG, TO KEEP DEBRIS, MUD AND DIRT FROM ENTERING THE DUCT.
3. DESIGN OF SLEEVE MUST COMPLY WITH SERVICE PROVIDERS CABLE PULLING REQUIREMENTS AND RECEIVE DESIGN AND INSTALLATION APPROVAL BY DESIGN SERVICES.
4. SEE SR-209, SR-215 AND/OR SR-312 FOR TRENCHING SPECIFICATIONS.
5. SEE SR-205 FOR APPROVED DUCT TYPES AND OPEN TRENCH INSTALLATION. IF A DIRECT BORE IS REQUIRED, APPROVED BORE-GARD AND HDPE DUCT SHALL BE USED FOR THE SECTION BORED. A BORING PROFILE REPORT SHALL BE PROVIDED UPON REQUEST. INSTALLATION DEPTH OF DUCT MUST BE VERIFIED BY DESIGN SERVICES FOR INSTALLATION TO BE APPROVED.
6. FOR EXISTING 5 INCH SLEEVES, THE 5 INCH DUCT SYSTEM MAY BE CONTINUED AFTER APPROVAL BY DESIGN SERVICES. THE 5 INCH DUCT WILL ONLY BE PERMITTED TO BE EXTENDED UNTIL REACHING A PIECE OF EQUIPMENT OR JUNCTION WHERE A TRANSITION CAN BE MADE TO 6 INCH DUCT. ANY 5 INCH DUCT USED FOR THIS PURPOSE MUST BE GREY PVC ELECTRICAL GRADE, SCHEDULE 40.

TRENCH & DUCT ENCASEMENT DRAINAGEWAY CROSSINGS

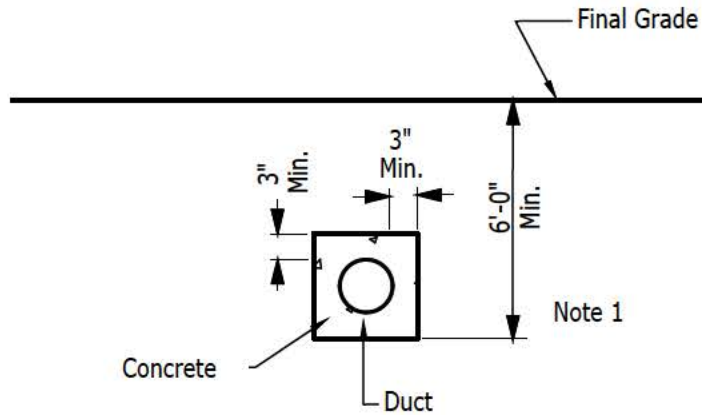
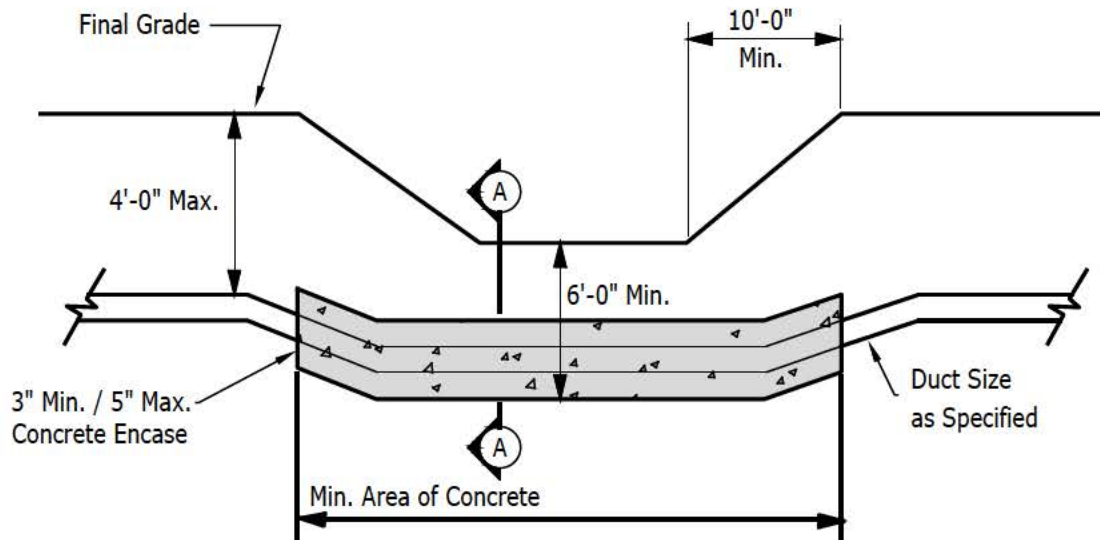

Section A-A

NOTE:



1. For duct installation requirements and concrete specifications, see SR-205.
2. For sleeve installation requirements see SR-210.

PEDESTAL AND SECONDARY JUNCTION BOX



NOTES:

1. Refer to SR-209 for trench detail and placement of equipment within easements.
2. Customer is to provide property pins and/or swing ties (stakes) to center of equipment. These pins/stakes must be in place for the trench/conduit and backfill/mandrel inspections. Company inspectors do not verify grade stakes. Any adjustments required to grade and/or pedestal sites due to inaccurate grading, grade changes and/or improper grade establishment at trench or pedestal sites will be the responsibility of the Developer/Contractor. Any associated costs to correct grade or pedestal sites and any costs incurred by Service Provider due to a change in the surface elevation will be borne by the customer.
3. Pedestal and trench sites shall be level and at final grade before calling Design Services for a trench/duct inspection.
4. Customer to ensure proper conduit placement during backfill process. Duct plugs are required for all conduits, use of duct tape to close ducts is not approved.
5. The service conduit shall be installed into the pedestal at the same time as the secondary conduits are installed. All conduits are to be tied up per the equipment detail, and prior to calling for the trench and conduit inspection.
6. Conduit sweeps into new or existing equipment shall be 2 1/2 inches x 36 inches x 90 degree, Grey PVC Electrical Grade, Schedule 40. Wave-rib conduit is NOT approved to be used for new installation into Company equipment.
7. After the conduits (SR-205) are in place, the customer is to install a #6 solid soft drawn copper conductor for Telco bonding from 2 feet above the sub grade (next to the right side of the conduits), 12 inches away from the front of the pedestal and 24 inches to the right of the equipment site. Bury the conductor 12 inches below final grade and coil up approximately 2 feet of conductor.
8. Do not trench under Company owned equipment without Service Provider personnel present. Service Provider's Access Crew can be scheduled to assist with conduit placement and/or trenching required under Company owned equipment. Arrangements must be made by calling 520-918-8300 (TEP) or 520-761-7951 (UES), a minimum of five working days in advance.
9. See SR-207 for bedding and backfill requirements.
10. See SR-108 for Right-of-way and Easement requirements.
11. The Company will provide the poly pedestal to the customer for install per SR-214.
12. If the customer chooses to utilize a subsurface pedestal (Secondary Junction Box) per SR-308/308A, the customer will purchase the approved 20k rated box for install.
13. The secondary junction box is to be installed per SR-214, levels the box so the top of the box is one inch above final grade and places the lid on the box.
14. Secondary junction box should not be installed within a concrete slab, sidewalk, driveway or driveway path. If limited space is available for installation of the secondary junction box, contact Design Services to review options.

		INITIATED BY	JAB	REVISION NO.	0	SR-214 Pg. 1 of 4
		ESR COMM.	7-25	ESR COMM.	-	
				EFFECTIVE DATE	7-25	

PEDESTAL AND SECONDARY JUNCTION BOX

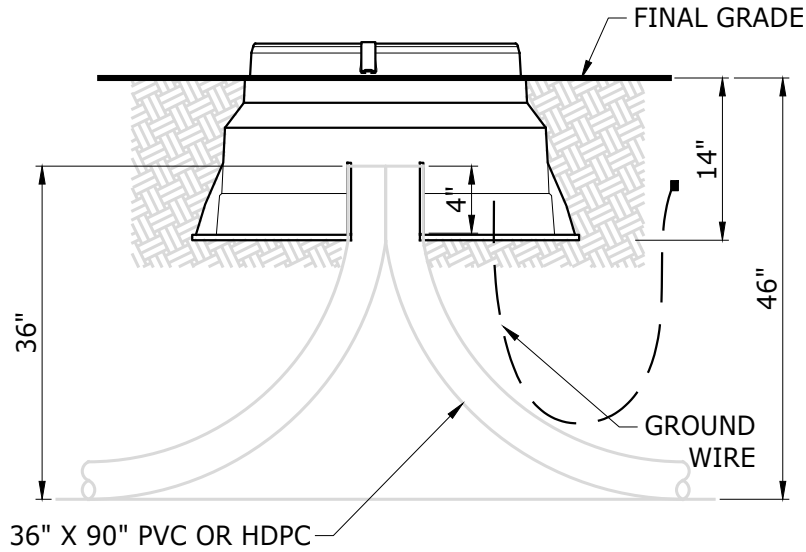

**SECONDARY PEDESTAL
FRONT VIEW**

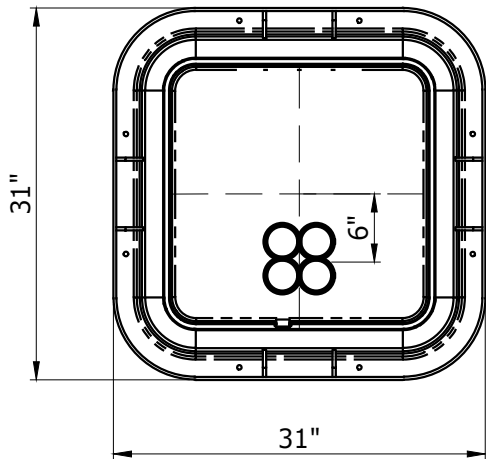

**SECONDARY PEDESTAL
TOP VIEW**

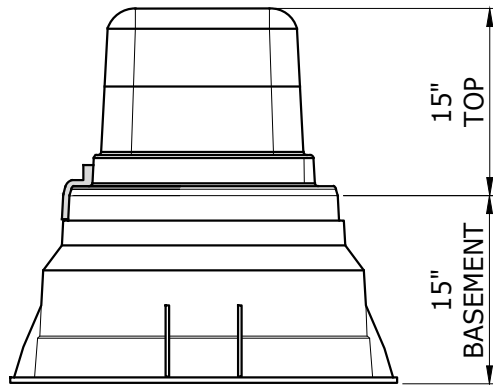

**SECONDARY PEDESTAL
SIDE VIEW**

PEDESTAL AND SECONDARY JUNCTION BOX

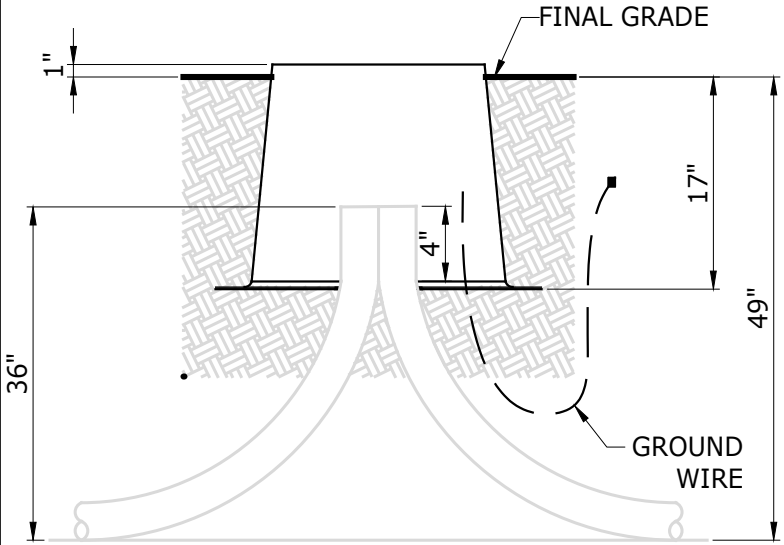

**SECONDARY JUNCTION BOX (J-10)
(CUSTOMER PROVIDED, OPTION)**

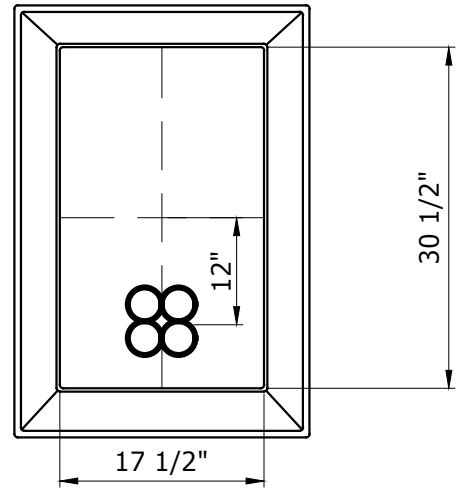

**SECONDARY JUNCTION BOX (J-10)
TOP VIEW**

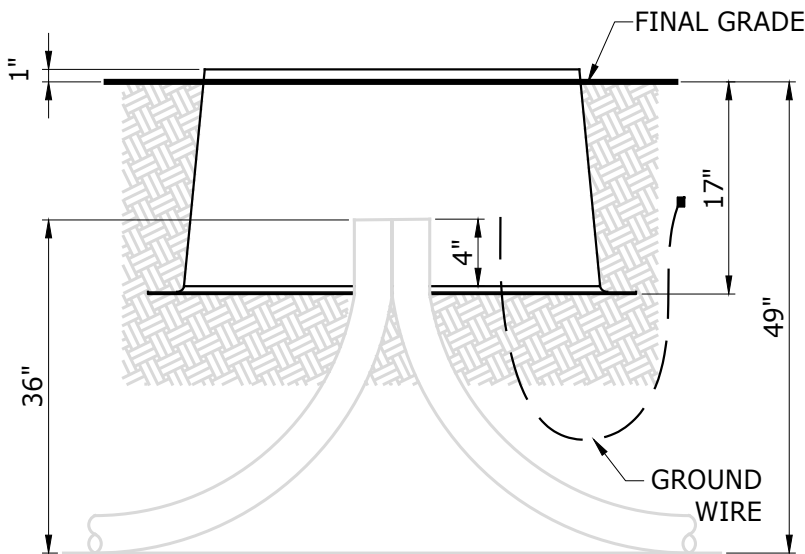

**SECONDARY JUNCTION BOX (J-30)
(CUSTOMER PROVIDED, OPTION)**

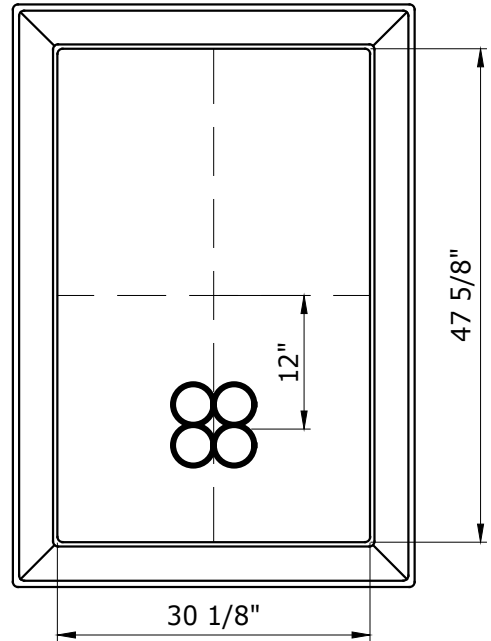

**SECONDARY JUNCTION BOX (J-30)
TOP VIEW**

NOTE:
FOR APPROVED MANUFACTURERS OF SECONDARY JUNCTION BOXES, REFER TO SR-308.

		INITIATED BY	TM	REVISION NO.	0	SR-214 Pg. 3 of 4
		ESR COMM.	7-25	ESR COMM.	-	
				EFFECTIVE DATE	7-25	

USE: EXISTING STEEL
PEDESTAL,
MAINTENANCE ONLY

PEDESTAL AND SECONDARY JUNCTION BOX



PROFILE VIEW

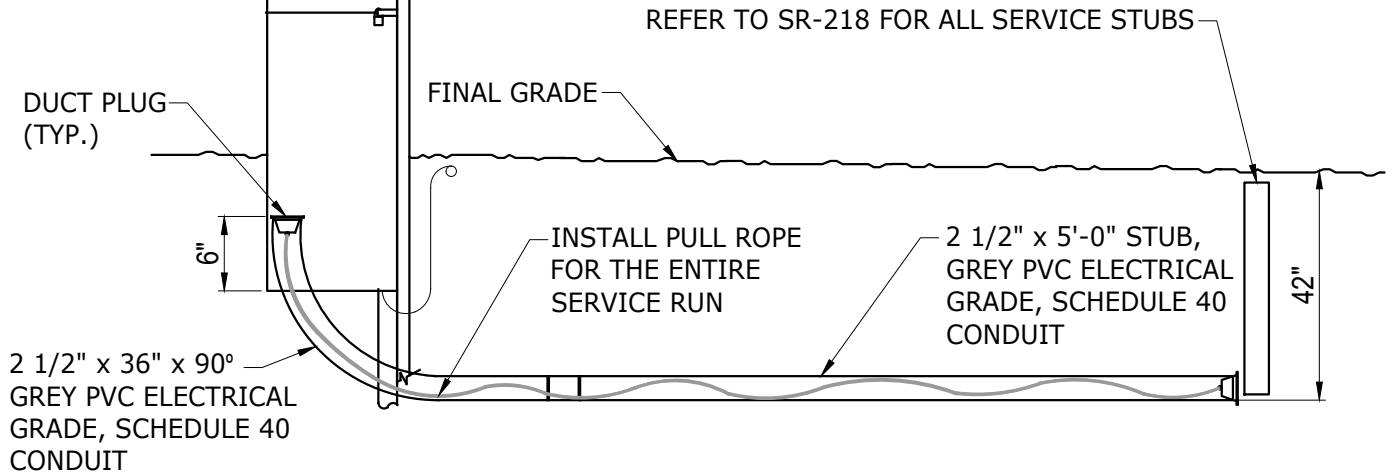

FRONT VIEW

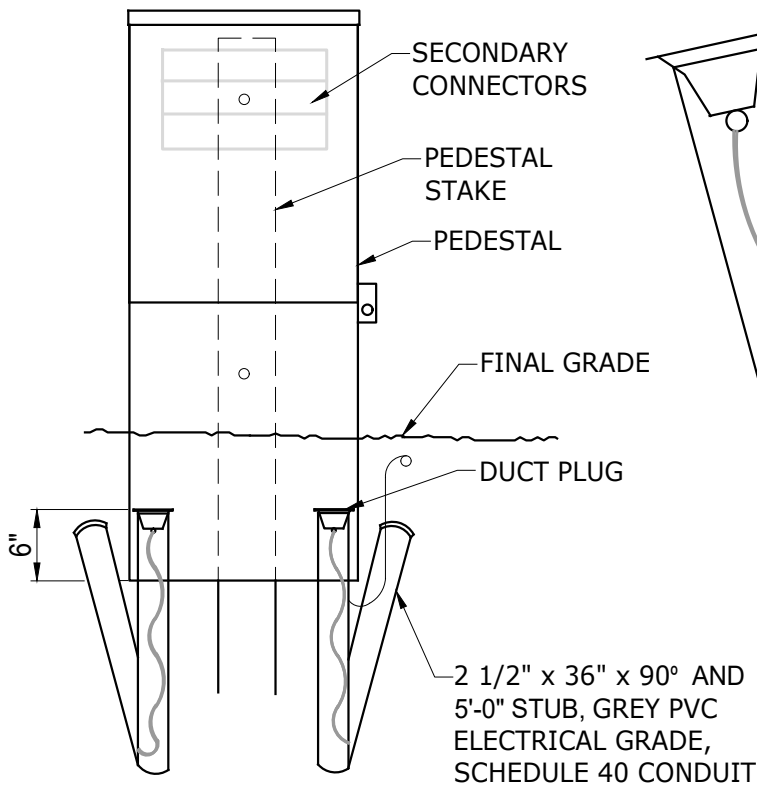

TOP VIEW

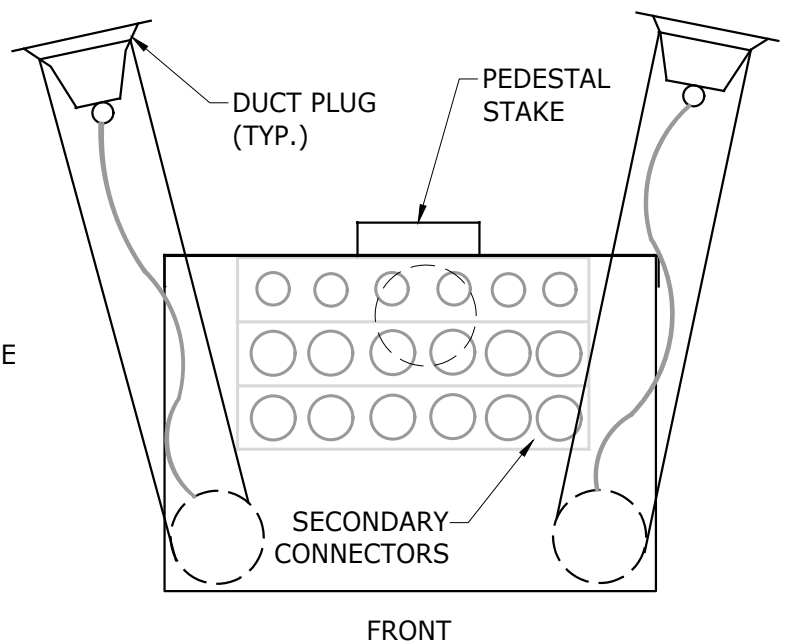

TRENCHING 2.5", 4" AND 6" DUCT

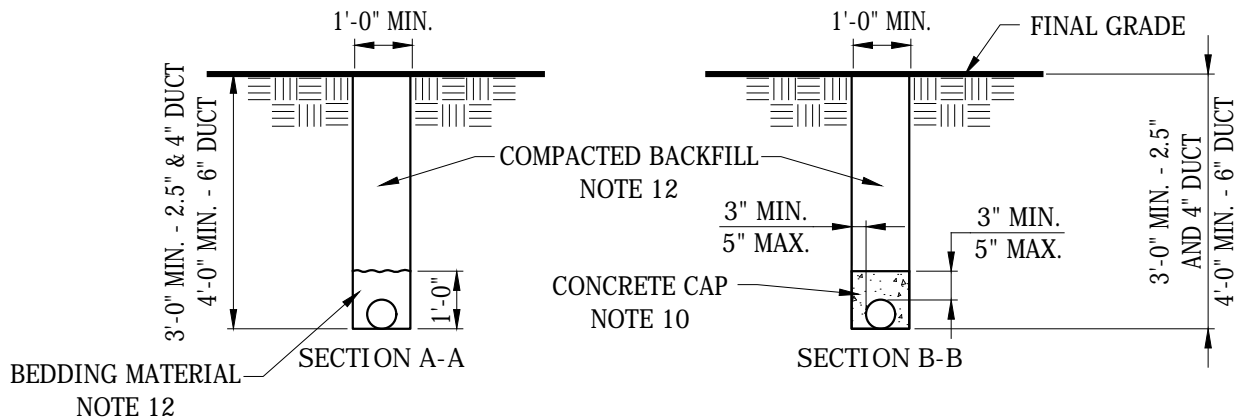
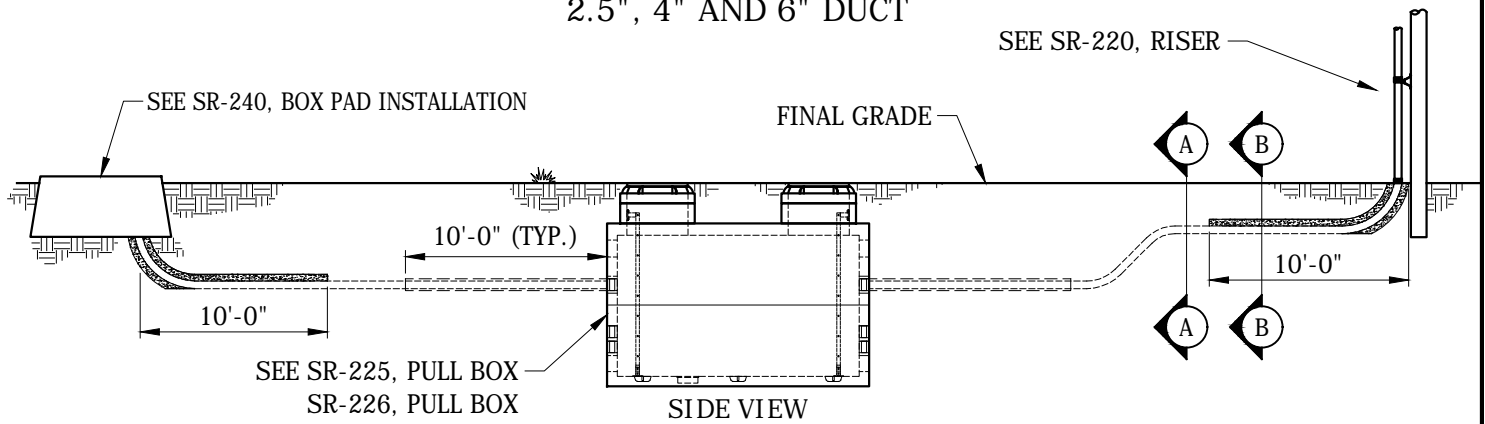

SEE ALSO:
 SR-232, 3Ø FUSED JUNCTION CABINET (F2) PAD
 SR-233, 3Ø TRANSFORMER/CAPACITOR PAD
 SR-234, 3Ø JUNCTION CABINET (J-2)
 SR-209, 1Ø TRANSFORMER, PEDESTAL & J-10
 SR-235, 1Ø JUNCTION CABINET (J-1)

NOTES:

1. Horizontal radius bends shall meet the following requirements:
 - Grey PVC electrical grade;
 - * Minimum radius of 12 ft. 6 inches for 2.5, 4 or 6 inch duct system
 - Wave-rib or Dura-line;
 - * Minimum radius of 4 ft. for 2.5 inch conduit
 - * Preferred radius of 12 ft. 6 inches for 4 or 6 inch duct system. A minimum of 4 ft. radius can be used if approved by Design Services.
2. Vertical radius bends at riser and pad-mounted equipment shall meet the following requirements:
 - Radius of 3 ft. for 2.5 or 4 inch conduit
 - Radius of 4 ft. for 6 inch conduit
3. Conduit sweeps into existing equipment shall be 2.5" x 36" x 90 degree, Grey PVC Electrical Grade, Schedule 40. Wave-rib conduit is NOT approved to be used in existing Company equipment.
4. Total of all deflections shall not exceed 360° in any continuous duct run between outlets.
5. Horizontal and vertical direction changes in the duct at the coupling shall not exceed 5 degrees.



(Notes continued on page 2)

		INITIATED BY	SC	REVISION NO.	15	SR-215
		ESR COMM.	6-78	ESR COMM.	9-19	
				EFFECTIVE DATE	9-19	

TRENCHING 2.5", 4" AND 6" DUCT

NOTES CONT'D:

6. All inactive duct ends shall be closed with appropriate duct plugs.
7. All duct ends and stubs shall be capped with appropriate duct plugs. For stub detail refer to SR-218.
8. Joints shall form a continuous smooth interior surface between joining duct sections to prevent cable damage.
9. Concrete of vertical sweeps is required for duct runs of more than 150 ft. in length or when 270° of bends or greater is present, regardless of length. Total bend shall not exceed 360° at any time.
10. Ducts entering pull boxes must be horizontal with the box and to be concrete encased for a distance of 10 ft. from the box.
11. For duct and concrete specifications and mandrel pull information, see SR-205.
12. For bedding and backfill material specifications, see SR-207.
13. Do not trench under Company owned pad-mounted equipment without Service Provider personnel present. Service Provider's access crew can be scheduled to assist with conduit placement and/or if trenching is required under Company owned equipment. Arrangements must be made by calling 520-918-8300 (TEP) or 520-761-7951 (UES), a minimum of five working days in advance.

 TEP Tucson Electric Power	 UniSourceEnergy SERVICES SANTA CRUZ COUNTY	INITIATED BY	GC	REVISION NO.	0	SR-215 Pg. 2 of 2
		ESR COMM.	9-19	ESR COMM.	-	

DUCT STUB DETAIL

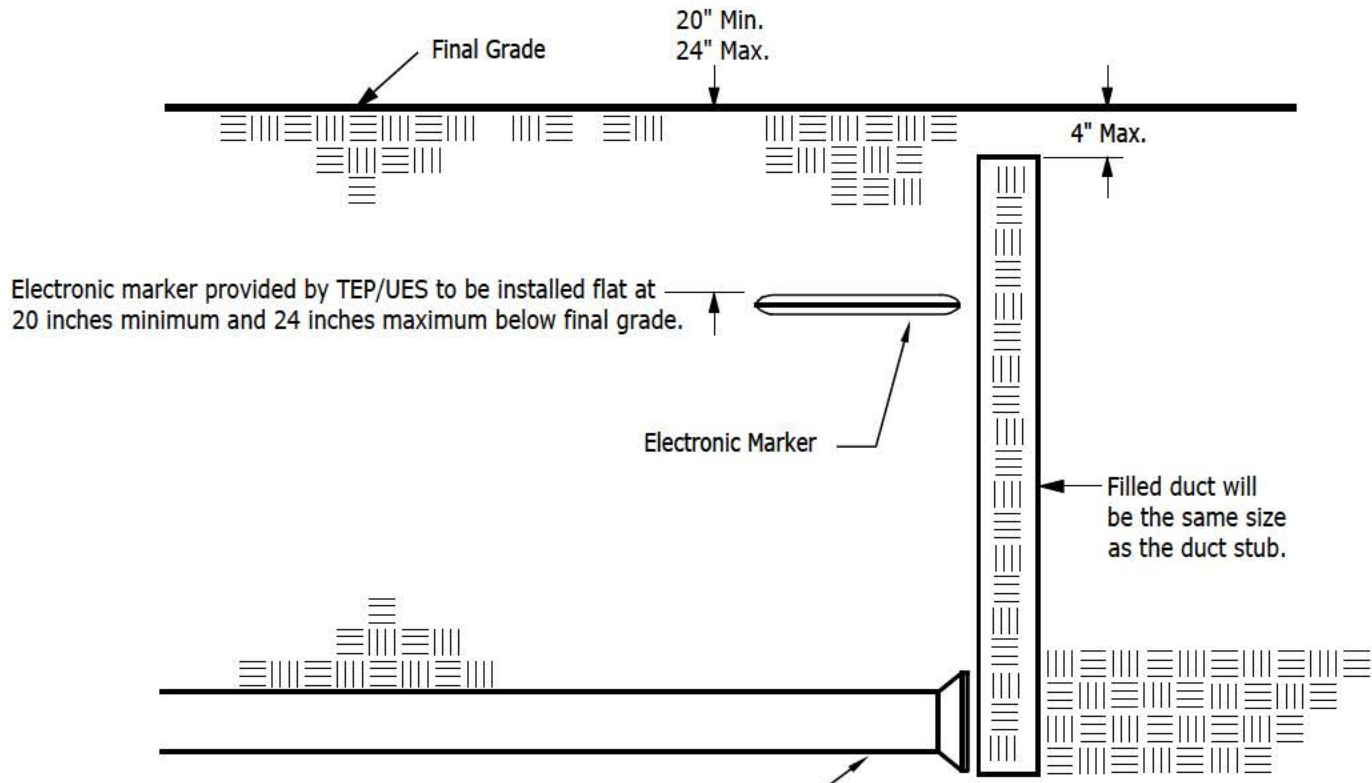

Electronic marker provided by TEP/UES to be installed flat at 20 inches minimum and 24 inches maximum below final grade.

Electronic Marker

Filled duct will be the same size as the duct stub.

Size and number of ducts as indicated on TEP/UES drawing. Plug open ends with duct plugs.

Inspection to be scheduled (TEP 918-8300 / UES 761-7951) to verify the Electronic Marker and Filled Duct installation

		INITIATED BY	SC	REVISION NO.	4	SR-218 Pg. 1 of 1
		ESR COMM.	10-91	ESR COMM.	1-17	
		ESR COMM.	10-91	EFFECTIVE DATE	1-17	

USE: Customer installed portion of riser on utility owned pole.

UNDERGROUND RISER CUSTOMER INSTALLED 2 1/2", 4" AND 6" CONDUIT

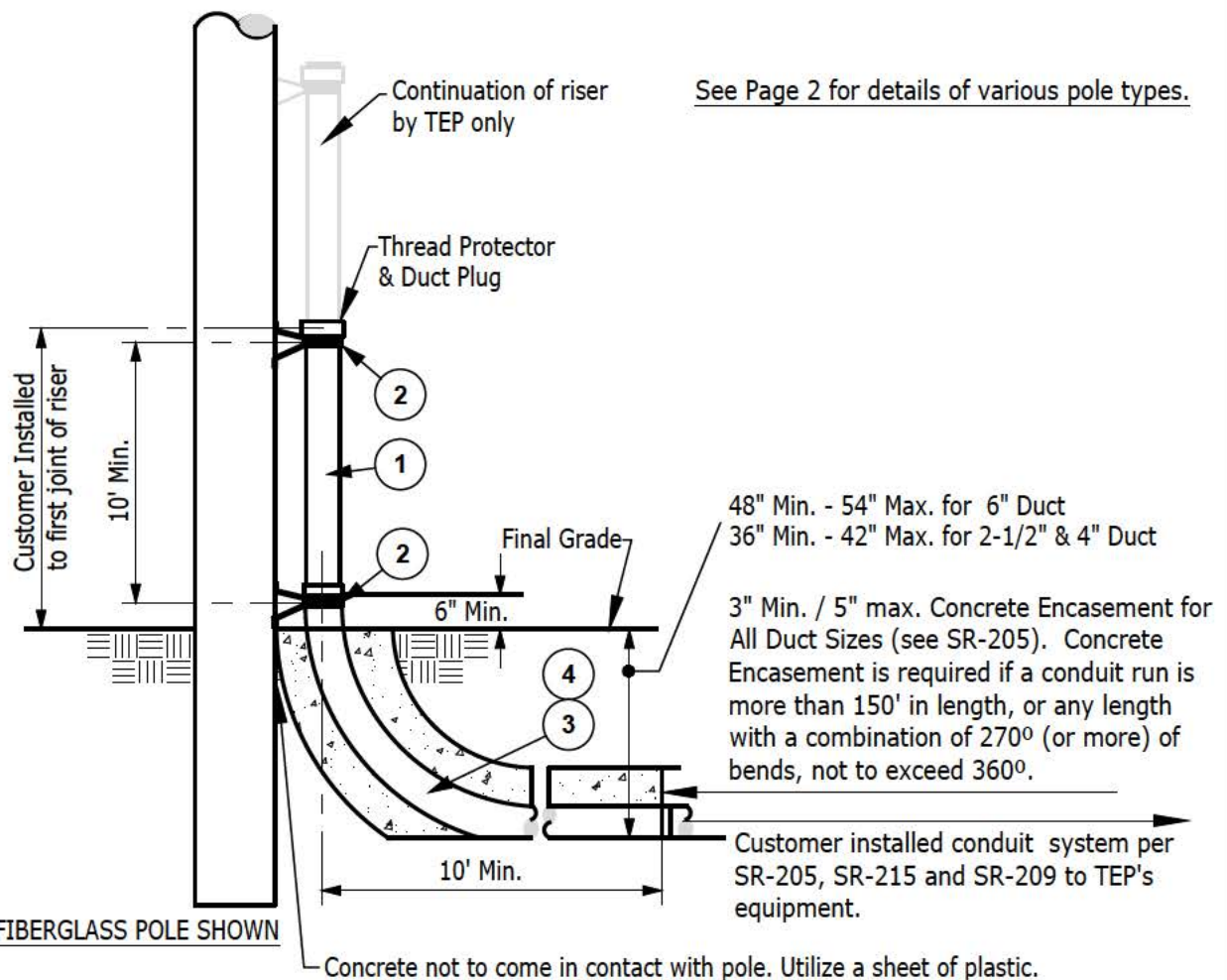

WOOD, STEEL, OR FIBERGLASS POLE SHOWN

NOTES:

1. Use the approved stand-off brackets & fasteners for pole type. (wood, steel, concrete & fiberglass).
2. If an additional riser is to be placed on the pole, it will be next to the existing riser, including Telco & CATV. See SR-221.
3. Rigid Steel, IMC, and Rigid Aluminum conduit must have a protective tape applied. The tape is to be installed starting 6" above final grade down beyond the (HDPE or PVC) coupling joint. Use 10 mil. protection tape in a half lap installation.

Item No.	Description
1.	Conduit, 2 1/2", 4" & 6" install conduit riser in the quadrant as specified by TEP. Rigid or intermediate galvanized steel, or rigid. 6" Rigid aluminum for 46kv installation.
2.	Standoff Bracket to be used on 2 1/2", 4" and 6" risers. 3/8" x 3" Lag Screws to be used to secure mounting hardware for 2 1/2" risers, 1/2" X 4" to be used on 4" & 6" risers. Concrete poles, use Band-it strapping. Steel poles and fiberglass poles, use Riv-Nut Inserts.
3.	90° x 48" minimum radius, rigid or intermediate galvanized steel for 6" conduit. Rigid aluminum for 46kv installation.
4.	90° x 36" minimum radius, rigid or intermediate galvanized steel for 2-1/2" and 4" conduit.

USE: Customer installed portion of riser on utility owned pole.

UNDERGROUND RISER CUSTOMER INSTALLED 2 1/2", 4" AND 6" CONDUIT

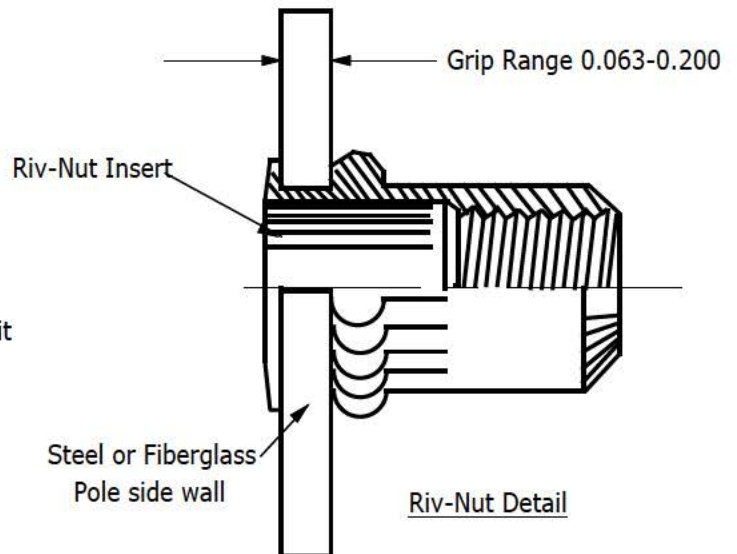
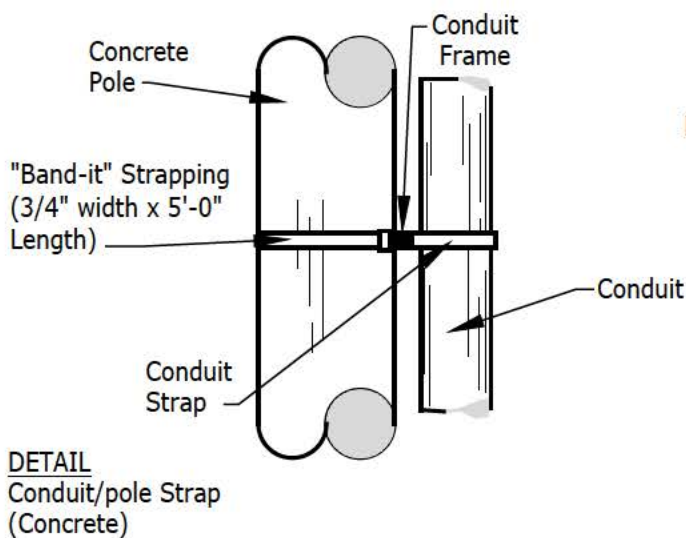
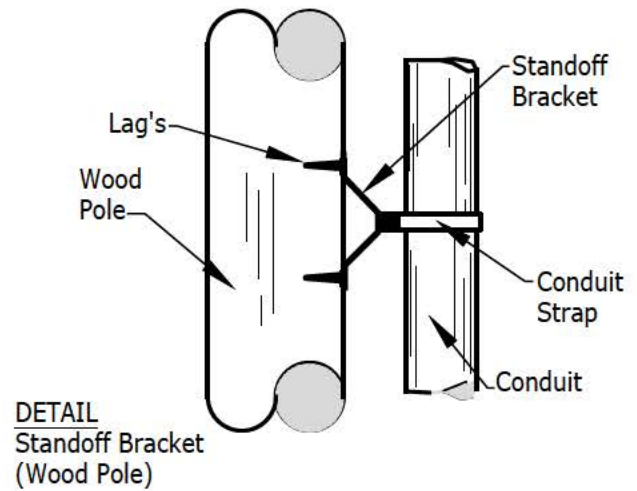
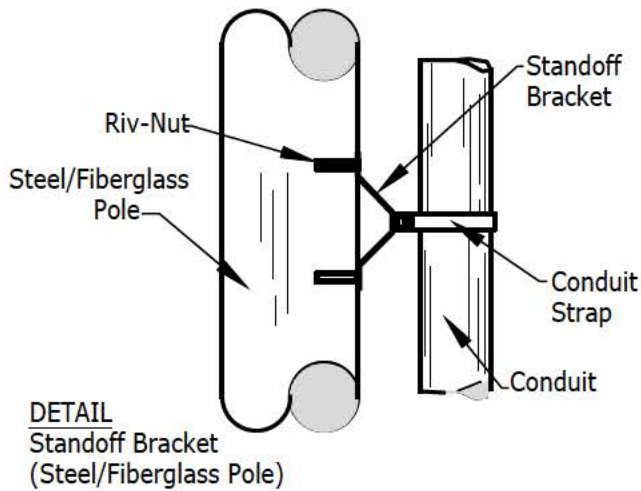

"Band-it"/UIC strapping
3/4" Strap Cat. No. G46099
Buckles Cat. No. G44099

➤ **Banding Kit***
Cat. No. G46099/G44099
*available at BSE, kit includes (2) 5'-0"
banding straps and (2) buckles

When mounting to concrete pole, use the conduit strap and the conduit frame with the strapping. The strapping bands must be installed with a Band-it tool, (Cat. No. G40269) This tool is available for rent and the strap is available from: Border States Electric - 294-1414

Aluma-Form Cat. No.
4-CSO-7/STK-2.5T 2 1/2"
4-CSO-7/STK-4T 4" 6"
4-CSO-10/STK-6T

A.B. Chance (Hubbell) Cat. No.
C4-CSO-7/STK-2.5T 2 1/2" 4"
C4-CSO-7/STK-4T
C4-CSO-10/STK-6T 6"

Riv-Nut Tooling
Installing tool - L-722-5013
Riv-Nut - AB66900

PULL BOX

REQUIREMENTS FOR INSTALLATION

1. Adhere to OSHA Standard - 29 CFR 1926.1200-1213. For assistance in compliance, OSHA publishes a compliance guide, see OSHA 38-09 2015 (or latest revision).
2. Duct size to be 4 inch or 6 inch as specified. See SR-215 for trenching and duct installation.
3. Duct shall be of a type specified by SR-205.
4. Excavation for the pull box shall be such that the top of the manhole will be at final grade plus or minus 1/4 inch.
5. Prior to setting, the customer shall provide a minimum of 3 inches of bedding material as specified in SR-207 as a base for the pull box. This bedding material should be compacted and graded level at the proper elevation. All backfill shall be placed progressively in 6 inch lifts and compacted to a minimum of 95 percent of Standard Proctor Density (ASTM D698). Service Provider reserves the right to require density (compaction) testing to verify conformance. If required, density (compaction) testing shall consist of one test at every two feet of vertical height of pull box backfill, alternating sides with successive two foot increments.
6. Pull box shall be located so that the duct will enter the pull box without any deflections.
7. Refer to Construction Drawing for duct size and duct placement. Where duct size, is other than 6 inches, endbell adapters will be provided by the pull box manufacturer to accommodate the duct size being installed.
8. Manhole is to be concreted to neck of pull box.
9. Manhole lid and ring to be furnished and installed by the customer.
10. Precast manhole grade rings require a sealer to be placed at each interface.
11. Ladder to be provided by the pull box manufacturer and installed by the customer.
12. Outside duct plugs to be provided in each endbell entrance into pull box.
13. Seal the manhole lid with manhole sealing compound after the last inspection has been approved. Service Provider locks the manhole lid.



REQUIREMENTS FOR SUPPLIER



14. Duct endbells are to be cast in place, flush with interior wall of pull box. All endbells are to be a standard 6 inch size and are to be placed as depicted for pull box A, B, C and D.



15. Duct identification letters to be embossed in concrete above each endbell on inside and outside walls of pull box A, B, C and D boxes (see expanded views).
16. All reinforcement steel shall be deformed billet steel conforming to ASTM A615, Grade 60.
17. Manhole lid standard marking to be "Electric", per lid detail on page 3.
18. The pull box manufacturer's name is to be embossed onto the inside top of the pull box.
19. Ground wire to be attached to rebar cage by thermal weld or by a bronze bolted parallel connector designed for bonding use. Example: Burndy Connector Cat. No. KVSU28.
20. All pulling irons to be rated for 20,000 lbs. minimum.
21. Supply 1-5 pound bag of manhole seal. Approved manufacturers are, Calpico - JM-5, Dottie - LHD5, or Ideal Industries, Inc. - 31-605.

		INITIATED BY	SC	REVISION NO.	21	SR-225 Pg. 1 of 12
		ESR COMM.	7-78	ESR COMM.	7-24	
		ESR COMM.	7-78	EFFECTIVE DATE	7-24	

Inside Dimensions W x L x H

PULL BOX: A - 5'-0" x 10'-0" x 7'-0"

B - 6'-0" x 12'-0" x 7'-0"

C - 10'-6" x 16'-0" x 8'-0"

D - 7'-0" x 16'-0" x 7'-0"

PULL BOX

DETAIL & CROSS SECTION

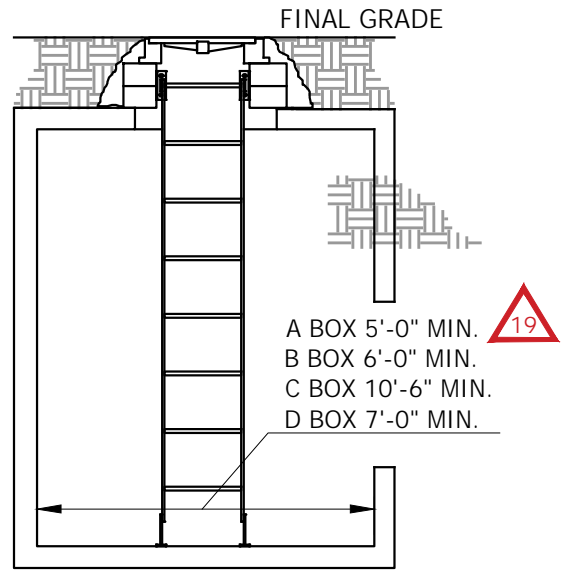
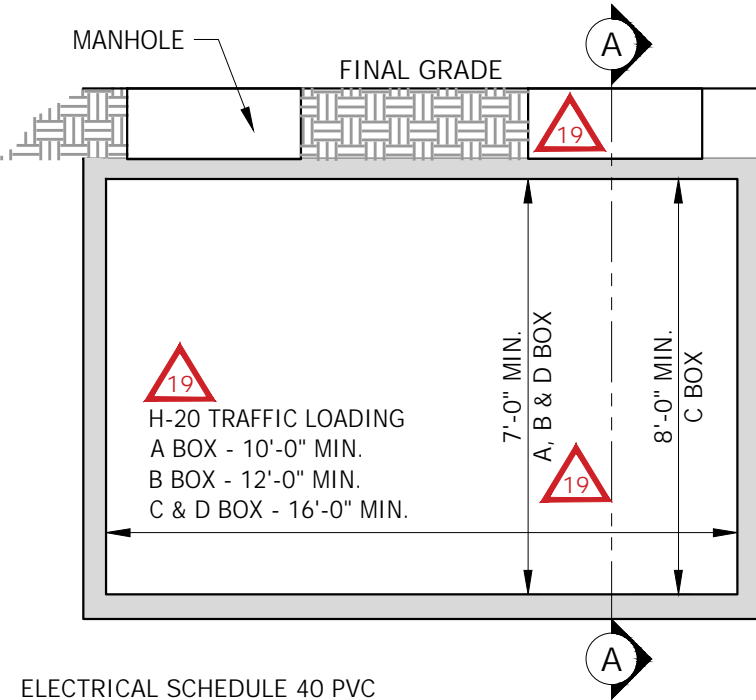

SECTION A-A

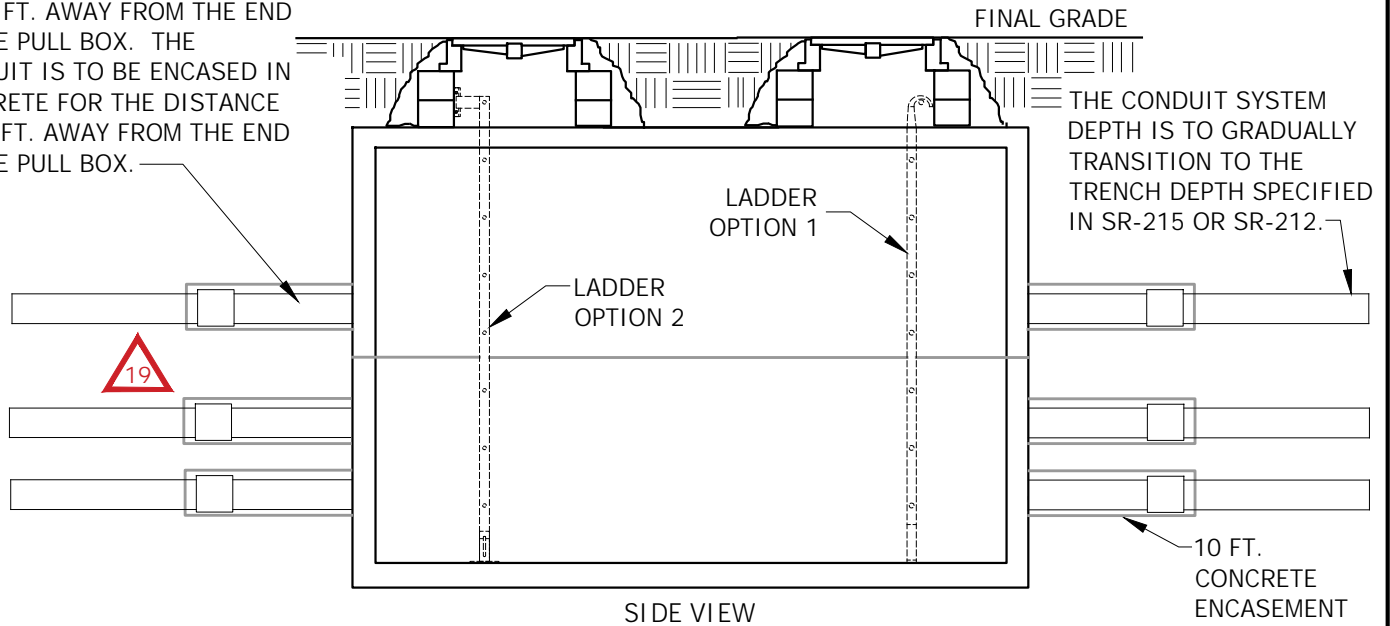

ELECTRICAL SCHEDULE 40 PVC SHALL BE INSTALLED FROM THE PULL BOX (STRAIGHT), UP TO 10 FT. AWAY FROM THE END OF THE PULL BOX. THE CONDUIT IS TO BE ENCASED IN CONCRETE FOR THE DISTANCE OF 10 FT. AWAY FROM THE END OF THE PULL BOX.



SIDE VIEW

NOTES:

1. SEE SERVICE PROVIDER CONSTRUCTION DRAWINGS FOR DUCT ENTRANCE LOCATIONS.
2. SERVICE PROVIDER RESERVES THE RIGHT TO REQUEST SPECIAL ENDBELL PLACEMENT BY THE MEANS OF CORE DRILLING EXISTING OR NEW PULL BOXES.
3. AN ACCESS APPOINTMENT MAY BE REQUIRED, SEE THE CONSTRUCTION DRAWINGS FOR DUCT ENTRANCE LOCATIONS.
4. APPROVED SUPPLIERS ARE RESPONSIBLE FOR MEETING SERVICE PROVIDER PULL BOX SPECIFICATIONS.

 Tucson Electric Power	 SANTA CRUZ COUNTY	INITIATED BY	SC	REVISION NO.	19	SR-225	
		ESR COMM.	7-78	ESR COMM.	7-24		Pg. 2 of 12
				EFFECTIVE DATE	7-24		

PULL BOX MANHOLE COVER DETAILS

NEENAH FOUNDRY: PART NO. 0150-5032, 196LBS.
(EFFECTIVE: MARCH 2019)

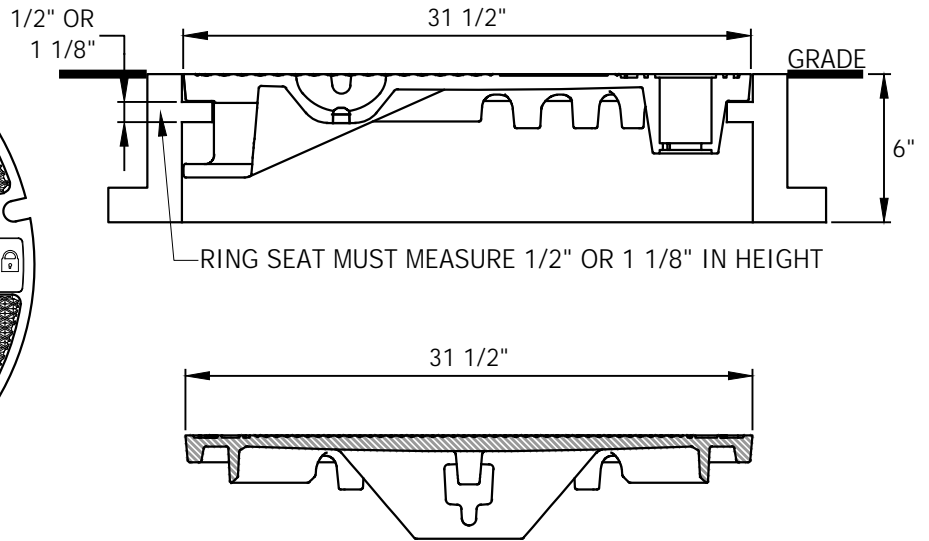
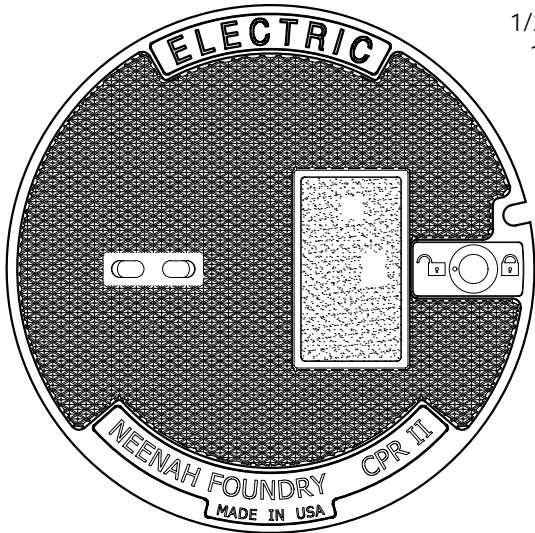

EAST JORDAN FOUNDRY: PART NO. 00342521A01, 190LBS.
(EFFECTIVE: OCTOBER 2023)

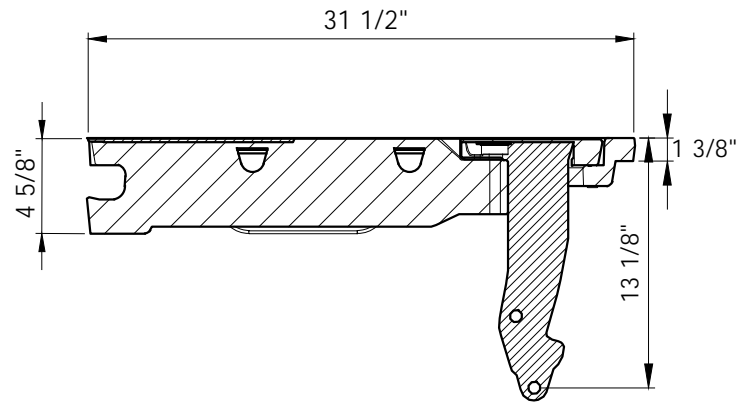
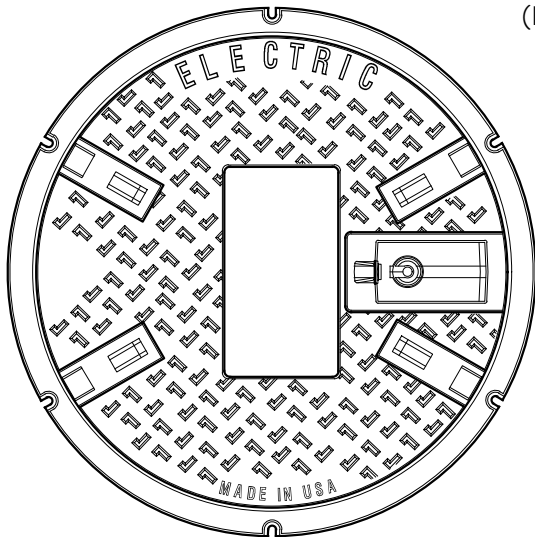

NOTES:

1. FURNISHED BY THE CUSTOMER AND INSTALLED IN THE UNLOCKED POSITION
2. MATERIAL: CAST DUCTILE IRON, ASTM A-536, 55+KSI YIELD
3. FINISH: NO PAINT UNLESS SPECIFIED ON PURCHASE ORDER
4. SUPPLIED WITH MCGARD LOCKING BOLT (SPECIFIED BY TEP) AND PLASTIC CAP.
5. TEP STORES NO. 7-48-2050

PULL BOX
MANHOLE GRADE RING DETAIL

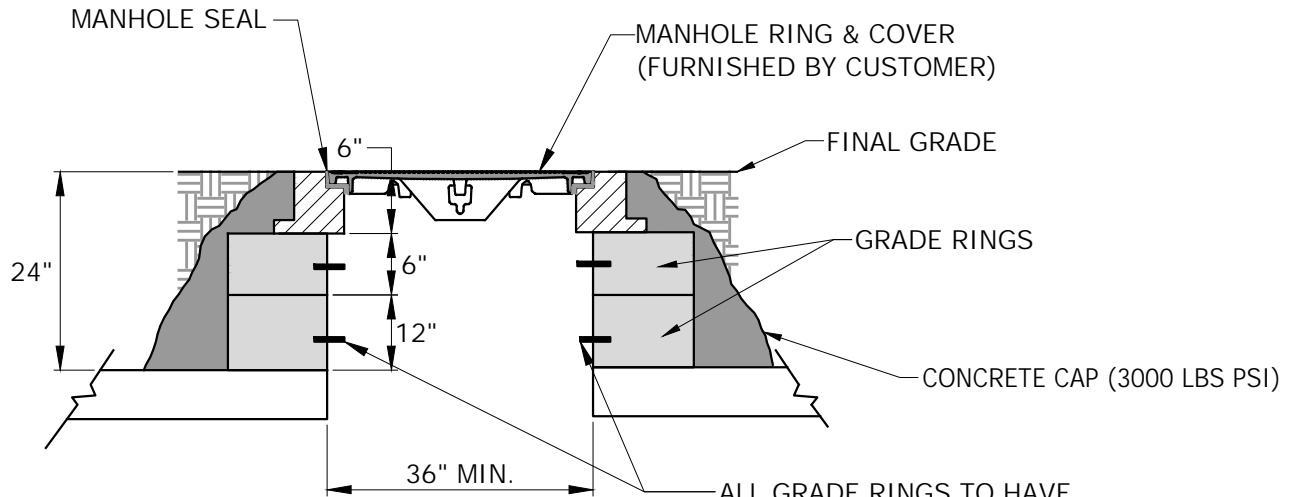

MANHOLE RING:

FURNISHED BY THE CUSTOMER.
 CAST IRON; H-20 TRAFFIC LOADING.
 RING TO CONTAIN LIFTING EYES.
 RING SEAT MUST MEASURE
 EITHER 0.5" OR 1.125" IN HEIGHT.

ALL GRADE RINGS TO HAVE
 RUNG INSERTS CAST IN PLACE
 ON TWO SIDES, TO BE
 FURNISHED BY THE CUSTOMER.

NOTES:

1. ALL GRADE RINGS TO BE 36 INCH MINIMUM DIAMETER, WITH LADDER RUNG IN EACH.
2. INFRA-RISER RUBBER COMPOSITE ADJUSTMENT RINGS ARE APPROVED FOR THE USE ON EXISTING INSTALLATIONS. THESE RINGS COME IN SIZES 1/2, 1, 2 & 3 INCH HEIGHTS FOR THE THREE SIZES OF COVERS LISTED IN EM-L59 PAGE 4 OF 4.

SUPPLIERS: BORDER STATES (LEAD TIME IS 2-6 WEEKS)
 JENSEN PRECAST (IN STOCK)

PULL BOX LADDER DETAILS

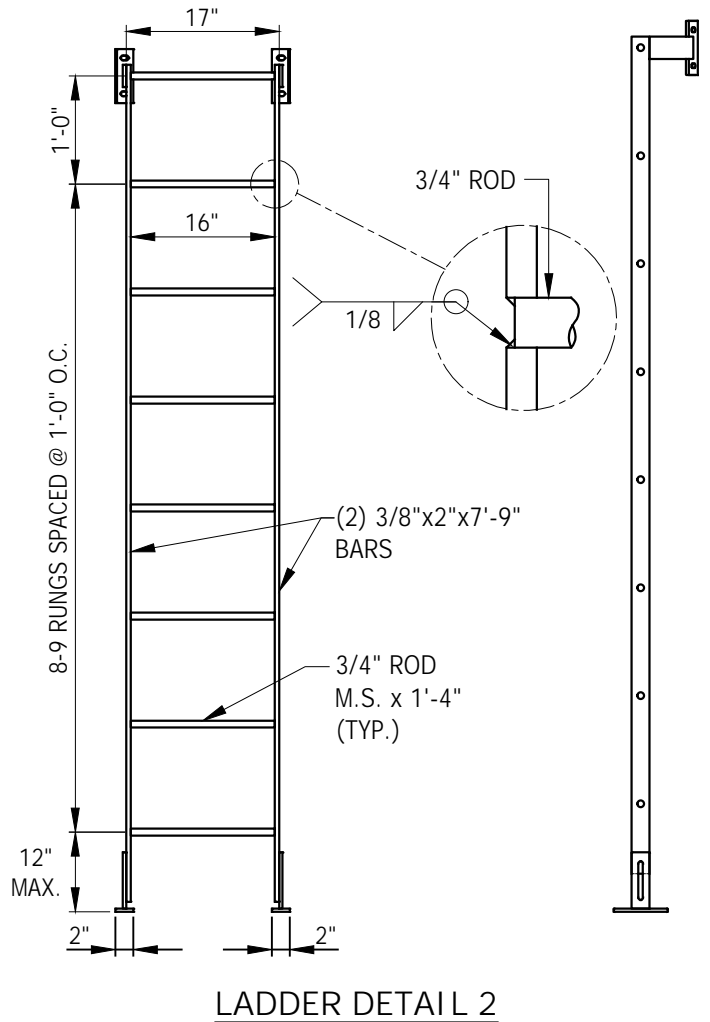
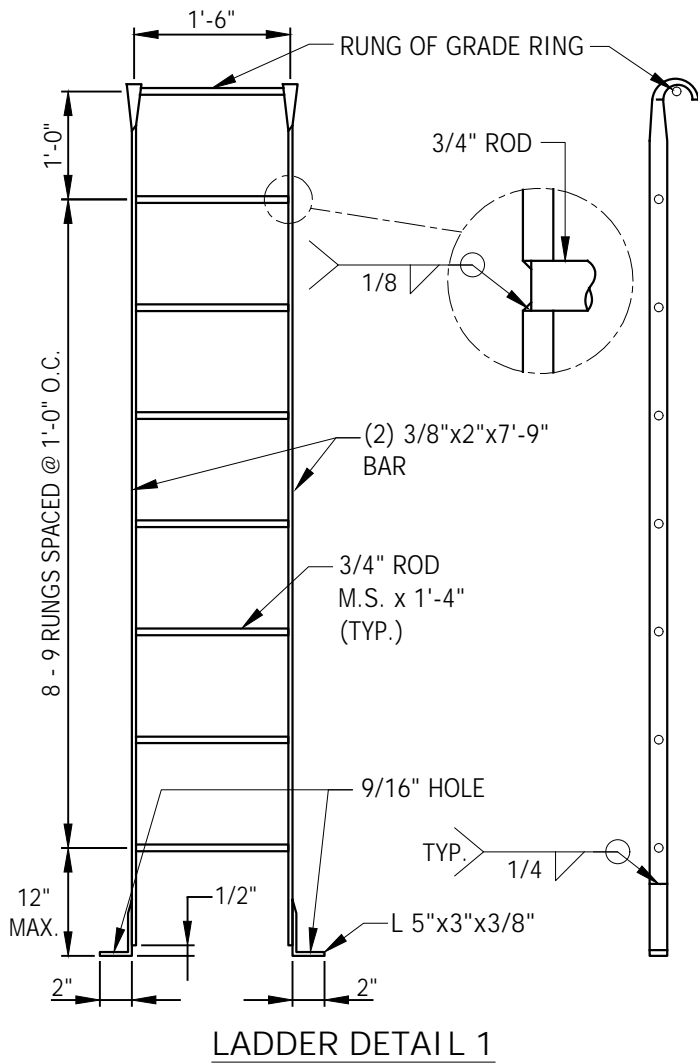

NOTES:



1. CUSTOMER TO FURNISH LADDERS IN PULL BOXES: A, B, C & D PULL BOX, (2) LADDERS PER PULL BOX.

2. LADDERS CONSTRUCTED AND INSTALLED PER ANSI A14.3 LATEST EDITION, FOR FIXED LADDER SAFETY REQUIREMENTS. A 24 INCH MINIMUM CLEAR ACCESS WITH LADDER IN PLACE MUST BE MAINTAINED.



3. FOR JENSEN PULL BOX A, B, C & D LADDER(S) SHALL BE HUNG FROM THE FIRST GRADE RING ABOVE THE PULL BOX FACING THE PORTS OF THE INTERIOR WALLS, THEN SECURELY FASTENED TO CONCRETE INSERTS CAST INTO THE FLOOR, REFER TO LADDER DETAIL 1.

4. FINISH: GALVANIZED

PULL BOX
EXPANDED VIEW PULL BOX A
 (5'-0" x 10'-0" x 7'-0")

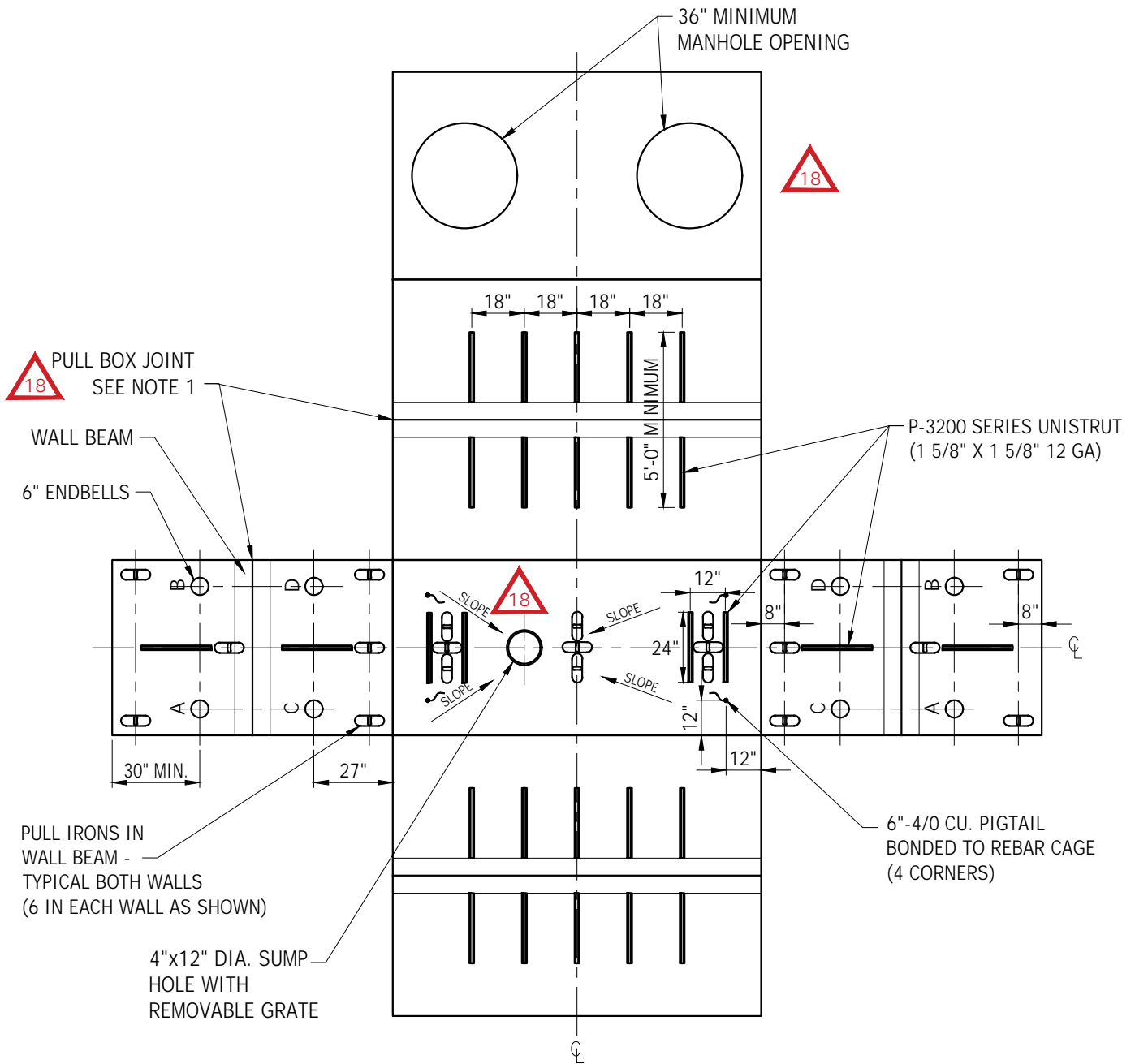

NOTES:

1. PULLBOX MAY BE CONSTRUCTED WITH OR WITHOUT A CENTER JOINT.

PULL BOX
EXPANDED VIEW PULL BOX B
 (Inside Dimensions: 6'-0" x 12'-0" x 7'-0")
FOR MAINTENANCE ONLY

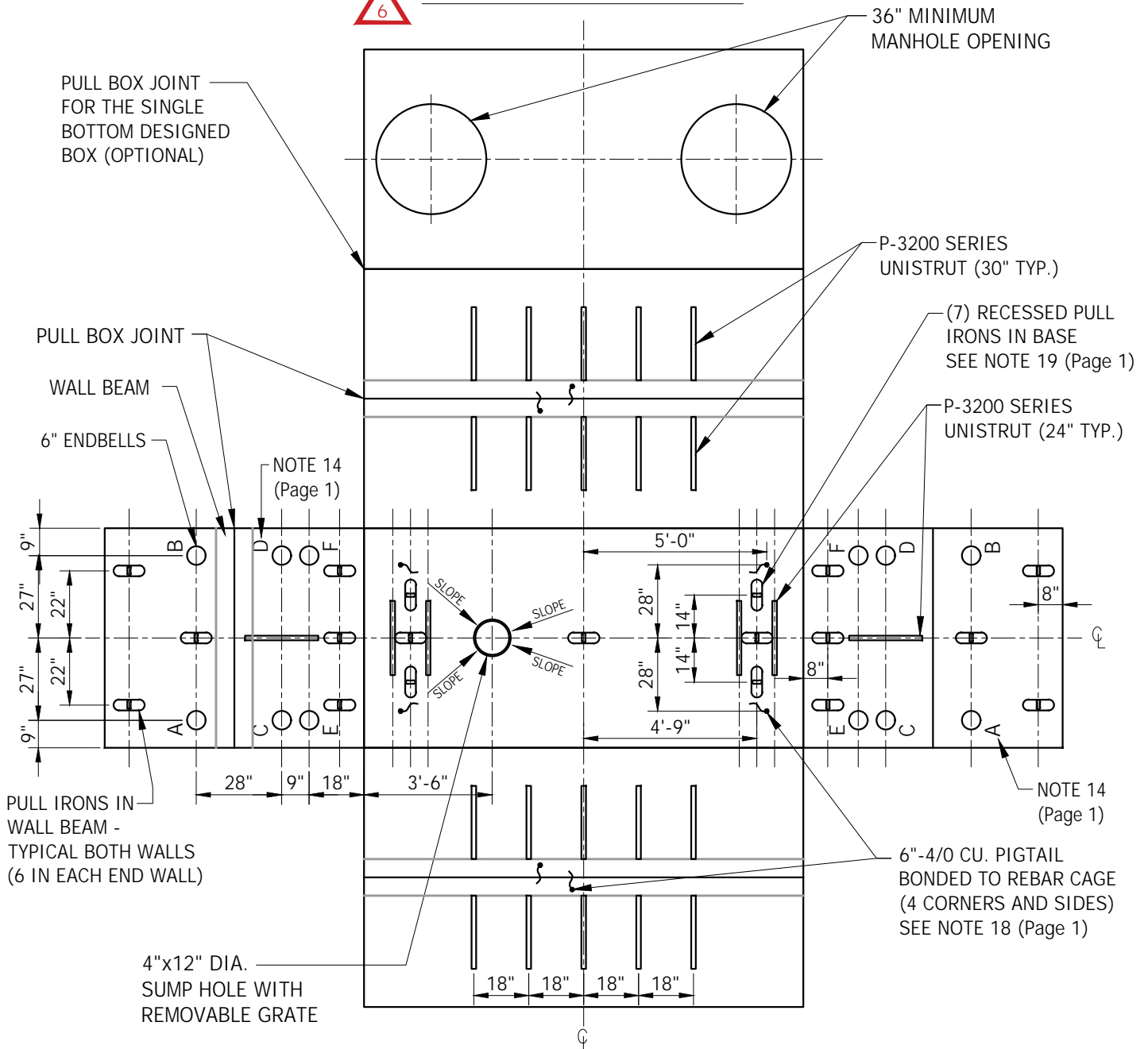

- NOTES:
1. SEE ADDITIONAL REQUIREMENTS ON PAGE 1.
 2. SEE TEP CONSTRUCTION DRAWINGS FOR DUCT ENTRANCE LOCATIONS.
 3. APPROVED SUPPLIERS:
 OLDCASTLE PRECAST
 JENSEN PRECAST

PULL BOX
PLAN, SIDE & END VIEW, PULL BOX B
 (1 Inside Dimensions: 6'-0" x 12'-0" x 7'-0")
FOR MAINTENANCE ONLY 4

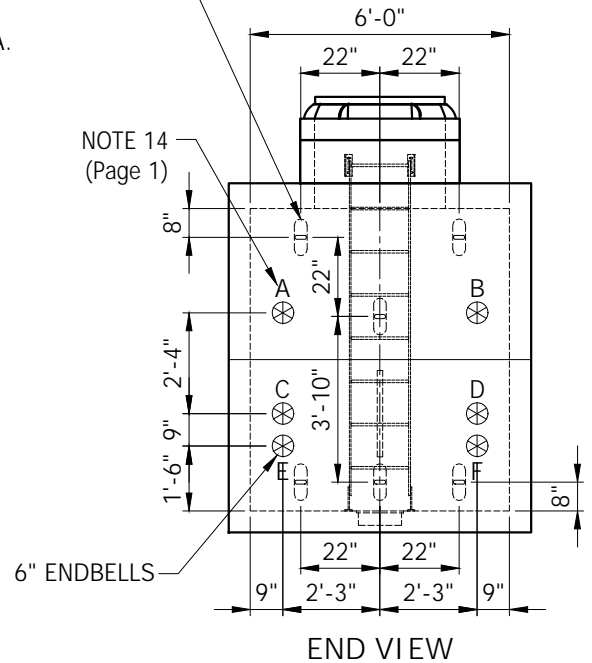
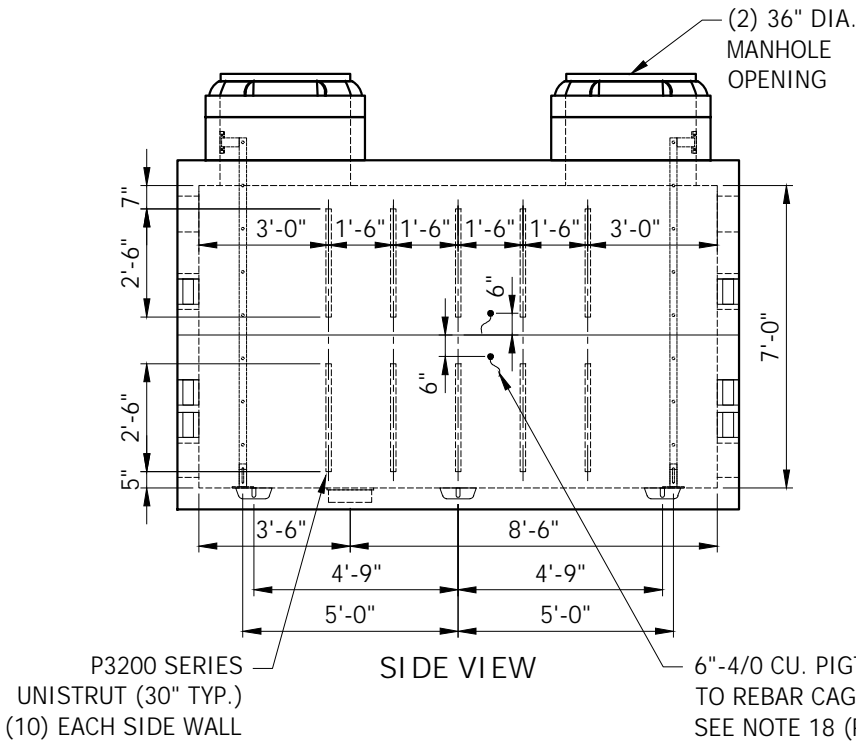
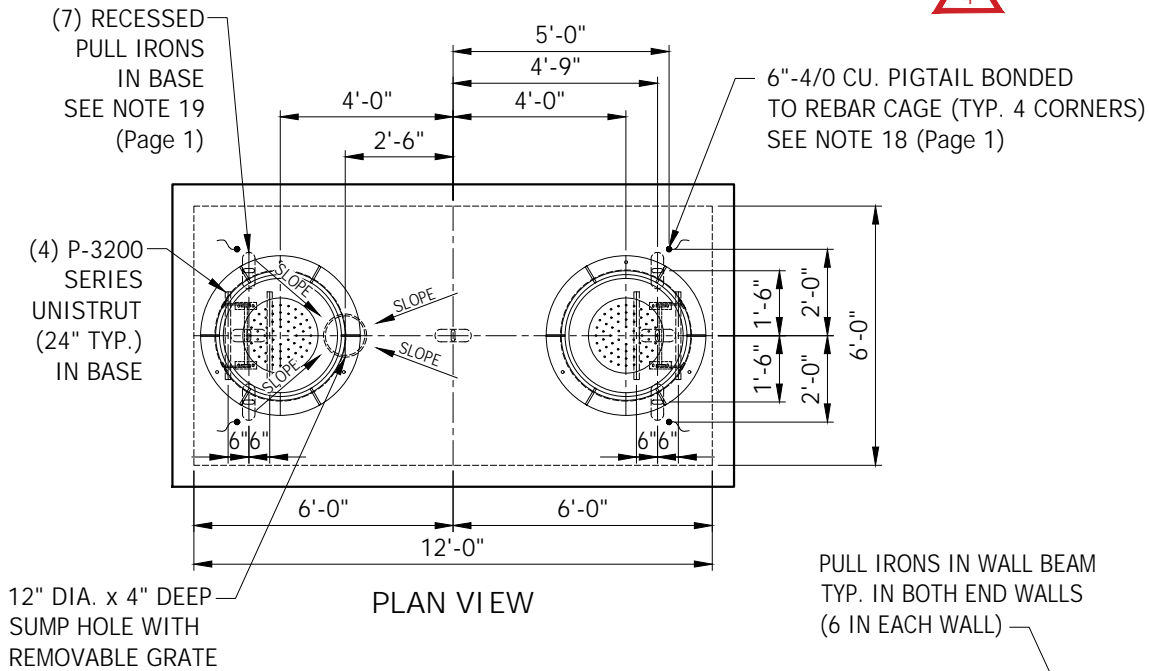

NOTES:

1. SEE ADDITIONAL REQUIREMENTS ON PAGE 1.
2. SEE TEP CONSTRUCTION DRAWINGS FOR DUCT ENTRANCE LOCATIONS.
3. APPROVED SUPPLIERS:
 OLDCASTLE PRECAST
 JENSEN PRECAST

PULL BOX
EXPANDED VIEW PULL BOX C
 (Inside Dimensions: 10'-6" x 16'-0" x 8'-0")
 FOR MAINTENANCE ONLY 

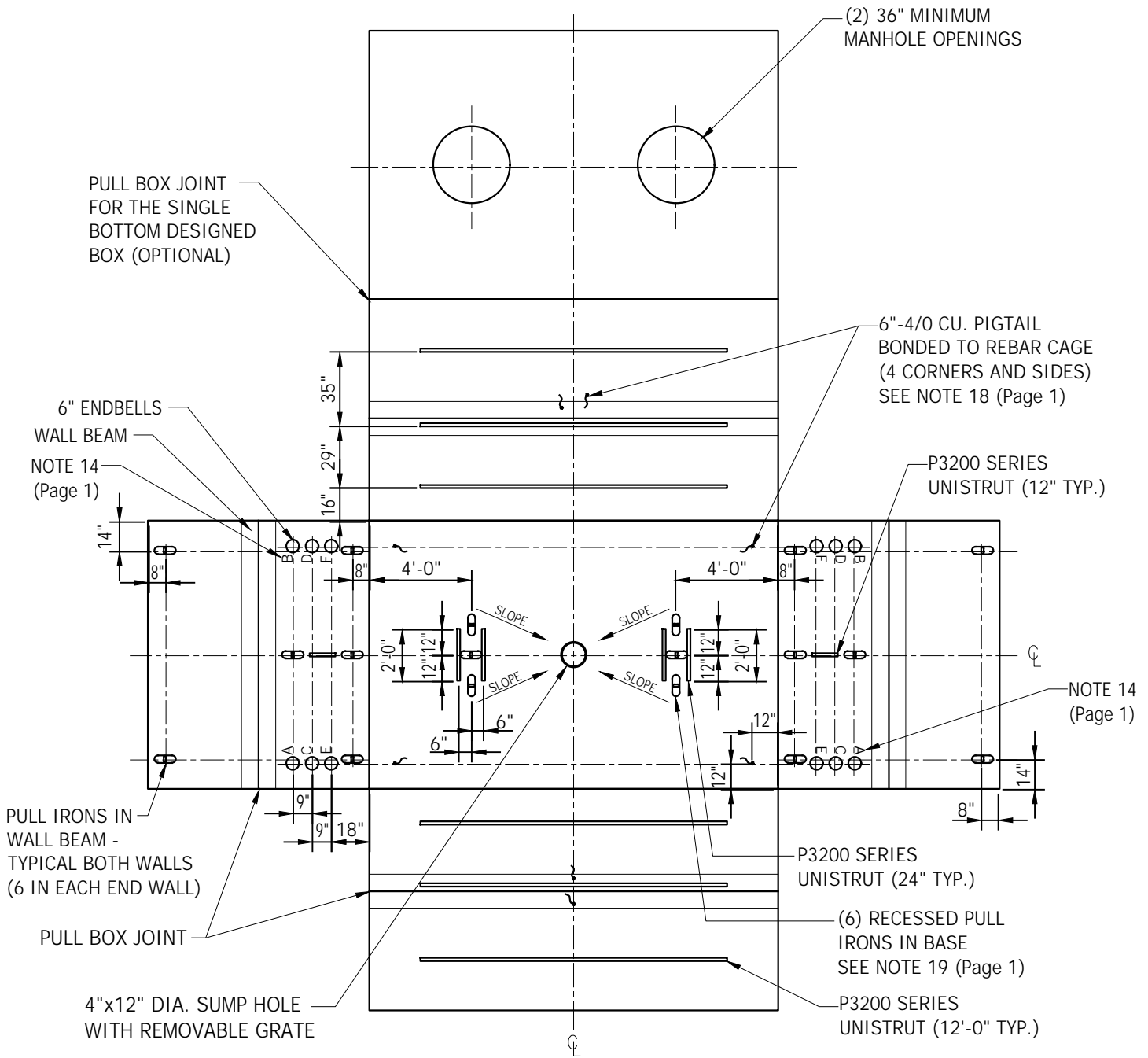

NOTES:

1. SEE ADDITIONAL REQUIREMENTS ON PAGE 1.
2. SEE TEP CONSTRUCTION DRAWINGS FOR DUCT ENTRANCE LOCATIONS.
3. APPROVED SUPPLIERS:
 OLDCASTLE PRECAST
 JENSEN PRECAST

PULL BOX

PLAN, SIDE & END VIEW, PULL BOX C (Inside Dimensions: 10'-6" x 16'-0" x 8'-0") FOR MAINTENANCE ONLY 3

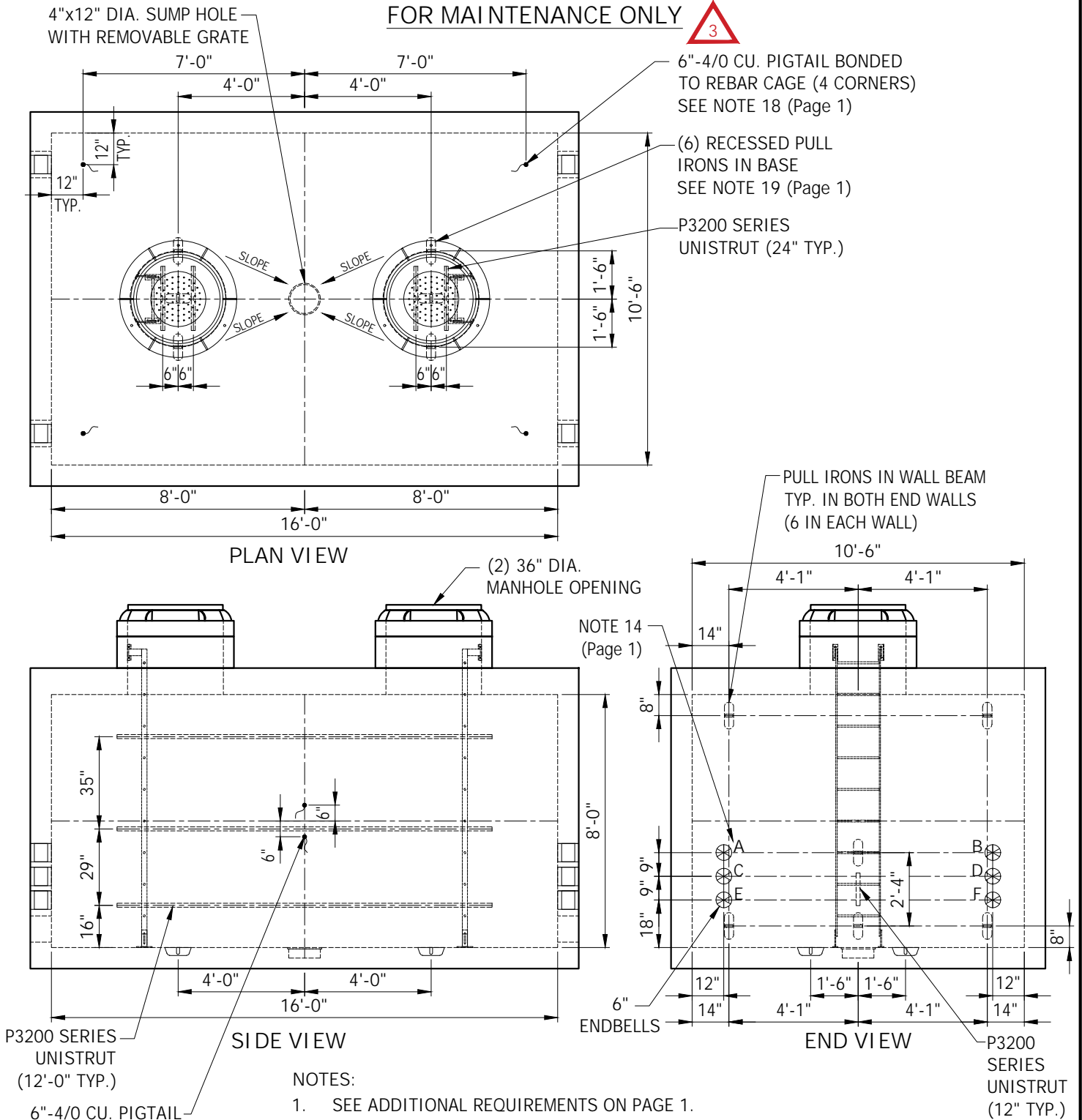

- NOTES:**
1. SEE ADDITIONAL REQUIREMENTS ON PAGE 1.
 2. SEE TEP CONSTRUCTION DRAWINGS FOR DUCT ENTRANCE LOCATIONS.
 3. APPROVED SUPPLIERS:

OLDCASTLE PRECAST
 JENSEN PRECAST

 Tucson Electric Power	 SANTA CRUZ COUNTY	INITIATED BY	SC	REVISION NO.	3	SR-225 Pg. 10 of 12
		ESR COMM.	7-78	ESR COMM.	7-24	
		ESR COMM.	7-78	EFFECTIVE DATE	7-24	

PULL BOX

EXPANDED VIEW, PULL BOX D

(Inside Dimensions: 7'-0" x 16'-0" x 7'-0")

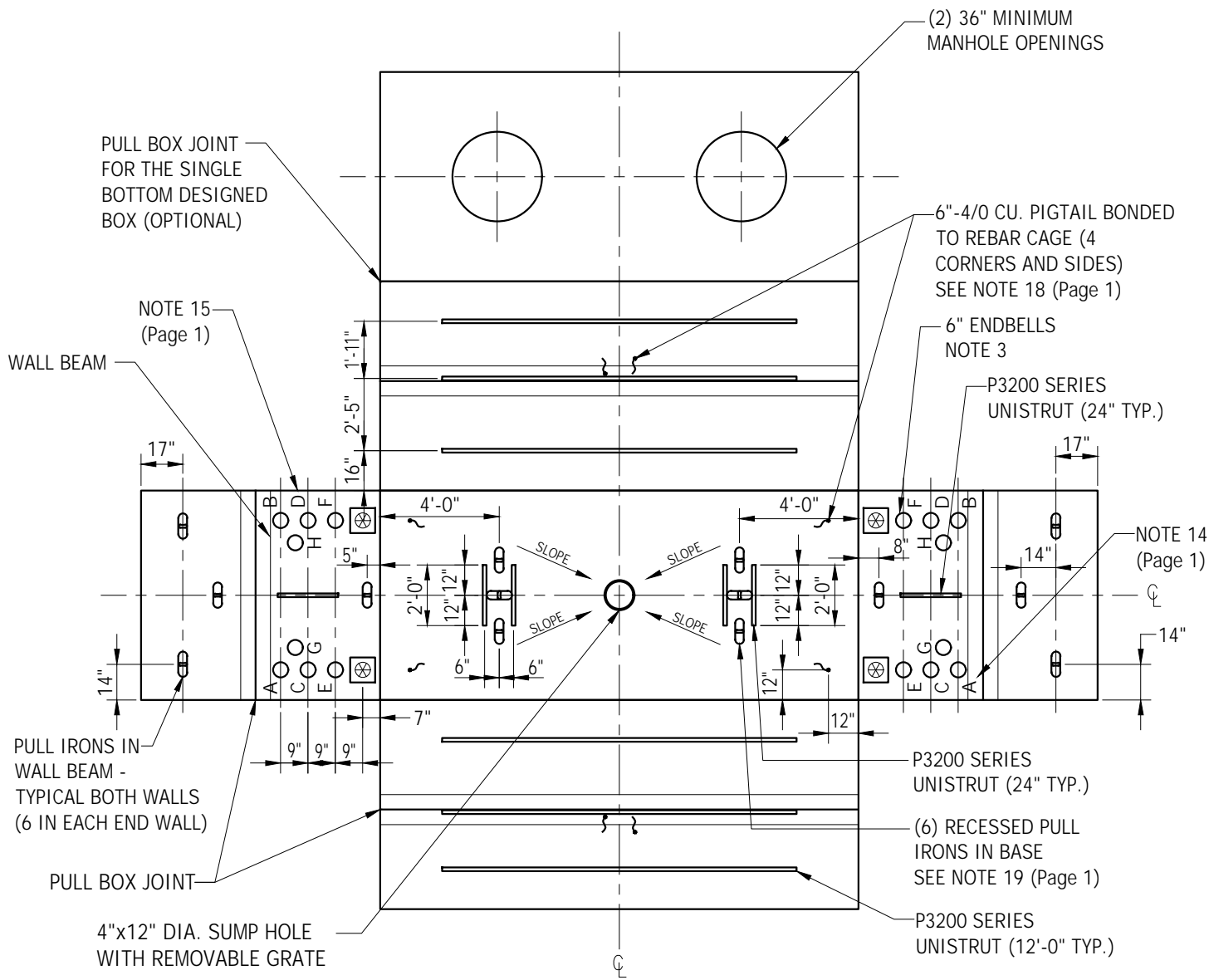

NOTES:

1. SEE ADDITIONAL REQUIREMENTS ON PAGE 1.
2. SEE TEP CONSTRUCTION DRAWINGS FOR DUCT ENTRANCE LOCATIONS.
3. NO REBAR TO BE INSTALLED BETWEEN GROUPED ENDBELLS.
4. APPROVED SUPPLIERS:

OLDCASTLE PRECAST
JENSEN PRECAST

PULL BOX

PLAN, SIDE & END VIEW, PULL BOX D (Inside Dimensions: 7'-0" x 16'-0" x 7'-0")

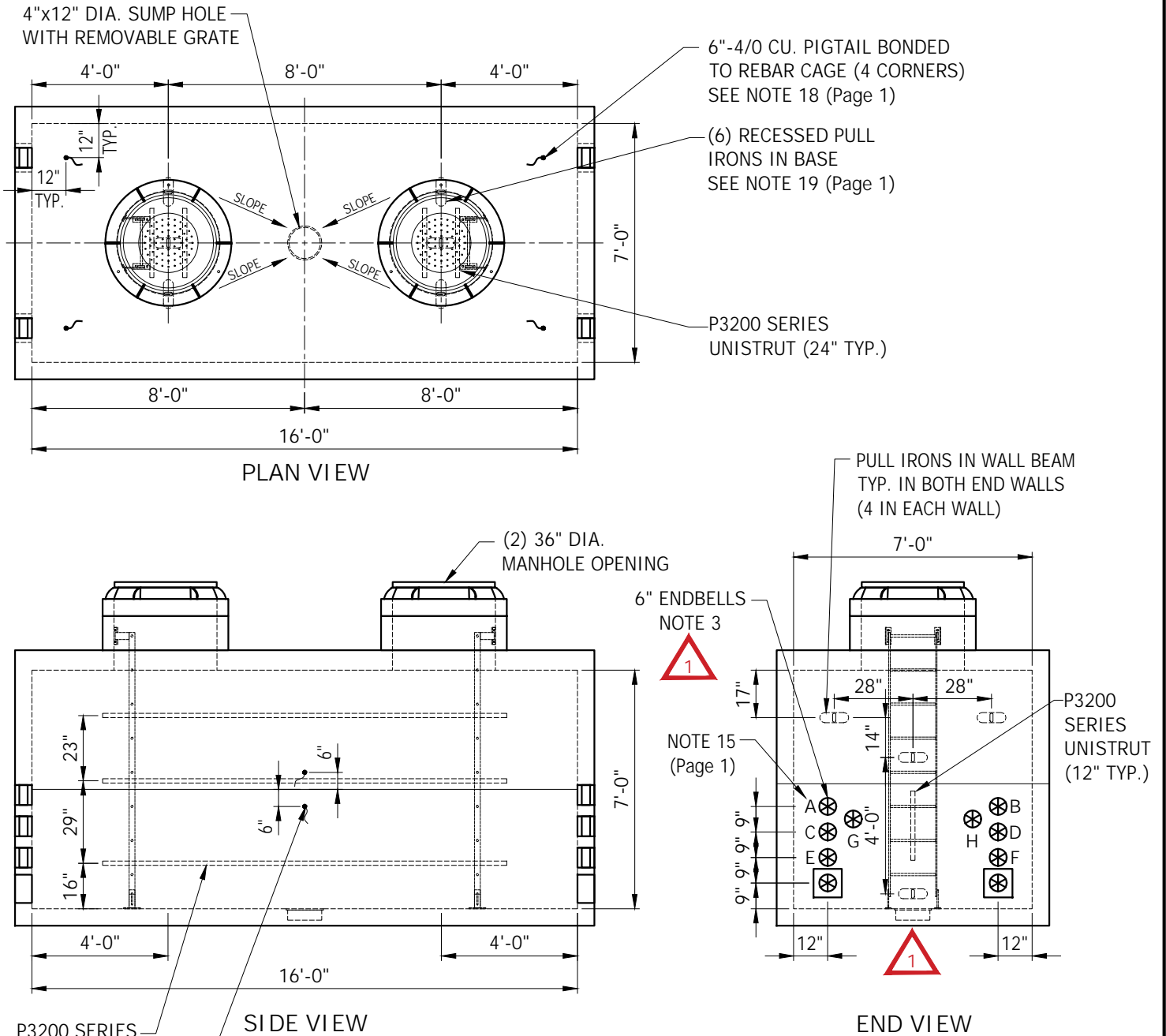

NOTES:

1. SEE ADDITIONAL REQUIREMENTS ON PAGE 1.
2. SEE TEP CONSTRUCTION DRAWINGS FOR DUCT ENTRANCE LOCATIONS.
3. NO REBAR TO BE INSTALLED BETWEEN GROUPED ENDBELLS
4. APPROVED SUPPLIERS:

OLDCASTLE PRECAST
JENSEN PRECAST

**USE: PRIMARY
PULLBOX FOR
THREE-PHASE
DISTRIBUTION AND
FEEDER.**

PULLBOX 15kV WITH LID

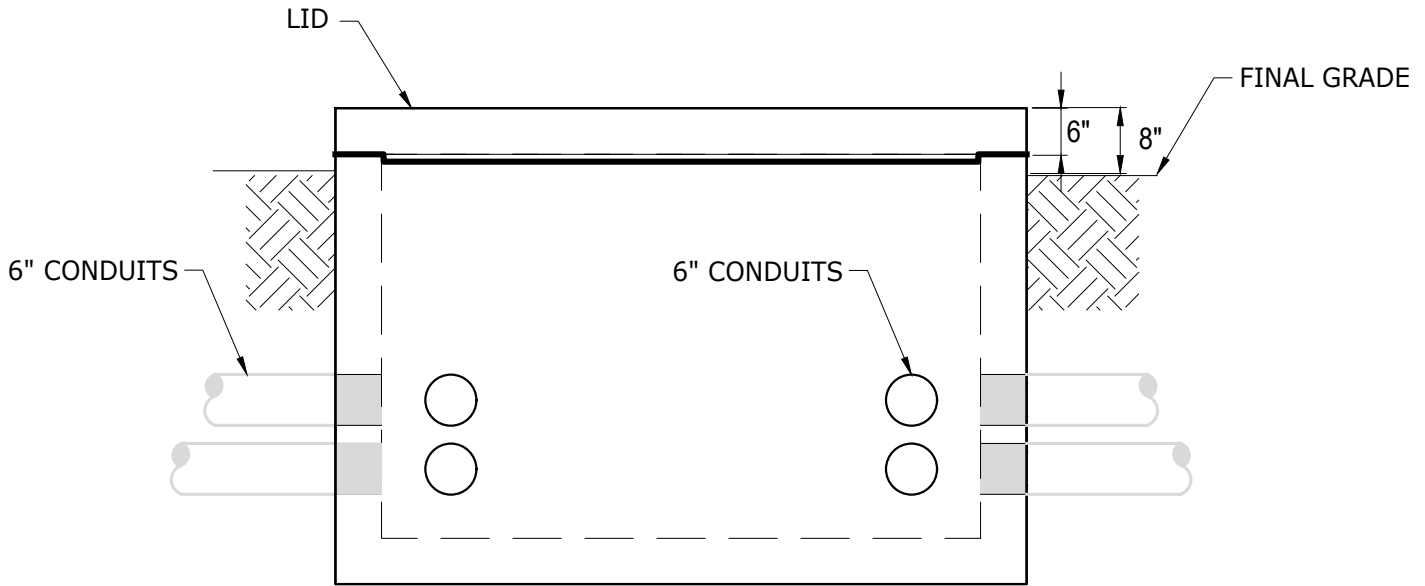

SIDE VIEW

NOTES:

1. EXCAVATION FOR THE PULL BOX SHALL BE SUCH THAT THE TOP OF THE BOX AND LID WILL BE 8" ABOVE FINAL GRADE.
2. THE PULL BOX WITH LID SHALL NOT BE INSTALLED IN AN AREA TO BE PAVED OR PRONE TO GRADE CHANGE, NOR SHALL IT BE SET IN A SIDEWALK OR BE LANDSCAPED OVER.
3. DUCTS ENTERING THE PULL BOX ARE TO BE INSTALLED WITHOUT ANY DEFLECTIONS
4. ADHERE TO OSHA STANDARD - 29 CFR 1926.1200-1213. FOR ASSISTANCE IN COMPLIANCE, OSHA PUBLISHES A COMPLIANCE GUIDE, SEE OSHA 38-09 2015 (OR LATEST REVISION).
5. DUCT SIZE TO BE 6 INCH AS SPECIFIED. SEE SR-215 FOR TRENCHING AND DUCT INSTALLATION.
6. DUCT SHALL BE OF A TYPE SPECIFIED BY SR-205.
7. PRIOR TO SETTING, THE CUSTOMER SHALL PROVIDE A MINIMUM OF 3 INCHES OF BEDDING MATERIAL AS SPECIFIED IN SR-207 AS A BASE FOR THE PULL BOX. THIS BEDDING MATERIAL SHOULD BE COMPACTED AND GRADED LEVEL AT THE PROPER ELEVATION. ALL BACKFILL SHALL BE PLACED PROGRESSIVELY IN 6 INCH LIFTS AND COMPACTED TO A MINIMUM OF 95 PERCENT OF STANDARD PROCTOR DENSITY (ASTM D698). SERVICE PROVIDER RESERVES THE RIGHT TO REQUIRE DENSITY (COMPACTION) TESTING TO VERIFY CONFORMANCE. IF REQUIRED, DENSITY (COMPACTION) TESTING SHALL CONSIST OF ONE TEST AT EVERY TWO FEET OF VERTICAL HEIGHT OF PULL BOX BACKFILL, ALTERNATING SIDES WITH SUCCESSIVE TWO FOOT INCREMENTS.
8. DUCT PLUGS ARE TO BE PROVIDED AND INSTALLED IN EACH ENDBELL.
9. INSTALL PROTECTIVE BARRIERS PER SR-230 WHERE PULLBOX MAY BE EXPOSED TO VEHICULAR TRAFFIC AND AS SHOWN ON CONSTRUCTION DRAWING.
10. THE LID SHALL NOT BE INSTALLED PRIOR TO ENERGIZATION TO ALLOW FOR INSPECTIONS. LID SHALL BE PLACED WITHIN 10 FEET OF THE BOX AND BE ACCESSIBLE FOR LINE CREWS TO INSTALL.



		INITIATED BY	SC	REVISION NO.	12	SR-226 Pg. 1 of 2
		ESR COMM.	2-77	ESR COMM.	7-25	
				EFFECTIVE DATE	7-25	



**USE: PRIMARY
PULLBOX FOR
THREE-PHASE
DISTRIBUTION AND
FEEDER.**

PULLBOX 15kV WITH LID

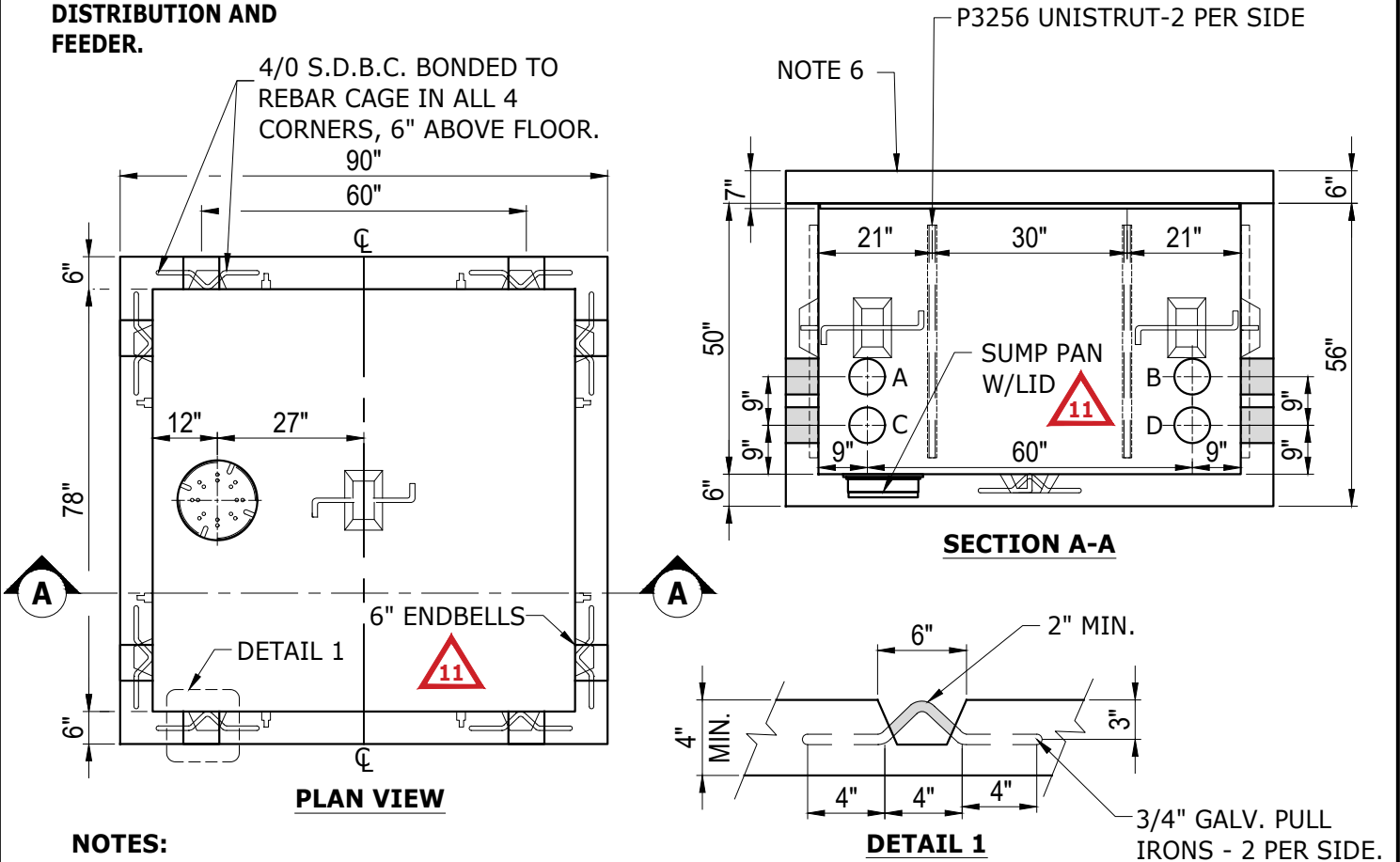

NOTES:

1. MATERIALS:

- A. REINFORCING BAR - SHALL CONFORM TO AC1-315 (LATEST REVISION)
- B. CONCRETE-MINIMUM STRENGTH, 5000 PSI AND SHALL CONFORM TO AC1-318 (LATEST REVISION) WITH A MINIMUM SLUMP OF 4".



- C. PULLING IRONS - 3/4"Ø M.S., HOT DIP GALVANIZED. SHALL BE RATED FOR 20,000 LBS. MINIMUM.

- 2. ALL BARS SHALL BE CUT TO CLEAR OPENINGS WITH 1-1/2" COVER.
- 3. LOADING: H-20 TRAFFIC RATED. NO SOIL SHALL COVER THE TOP OF BOX. COVER SHALL BE STAMPED "H-20".
- 4. APPROVED SUPPLIERS - JENSEN PRECAST, BOX AND SOLID LID CATALOG #200084576, SOLID LID ONLY CATALOG #200084574, ADAPTER LID ONLY CATALOG #200098340.
- 5. GROUND WIRE SHALL BE ATTACHED TO REBAR CAGE BY THERMAL WELD OR BY A BRONZE BOLTED PARALLEL CONNECTOR DESIGNED FOR BONDING USE.
- 6. APPROXIMATE WEIGHT OF THE CONCRETE LID IS 6,000 LBS.



- 7. DUCT ENDBELLS ARE TO BE CAST IN PLACE, FLUSH WITH INTERIOR WALL OF PULL BOX. ALL ENDBELLS ARE TO BE A STANDARD SIX INCH SIZE AND ARE TO BE PLACED AS DEPICTED.



- 8. DUCT IDENTIFICATION LETTERS TO BE IMBOSSED IN CONCRETE AT EACH ENDBELL ON THE INSIDE AND OUTSIDE WALLS OF PULL BOX.

		INITIATED BY	SC	REVISION NO.	11	SR-226 Pg. 2 of 2
		ESR COMM.	2-77	ESR COMM.	5-25	
				EFFECTIVE DATE	5-25	

EQUIPMENT BARRIER



Use: Protect equip. from damage.

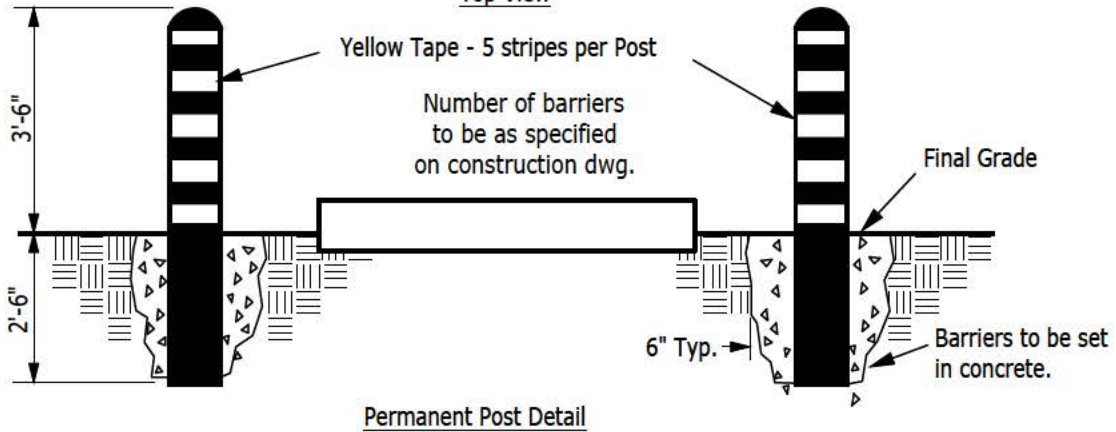
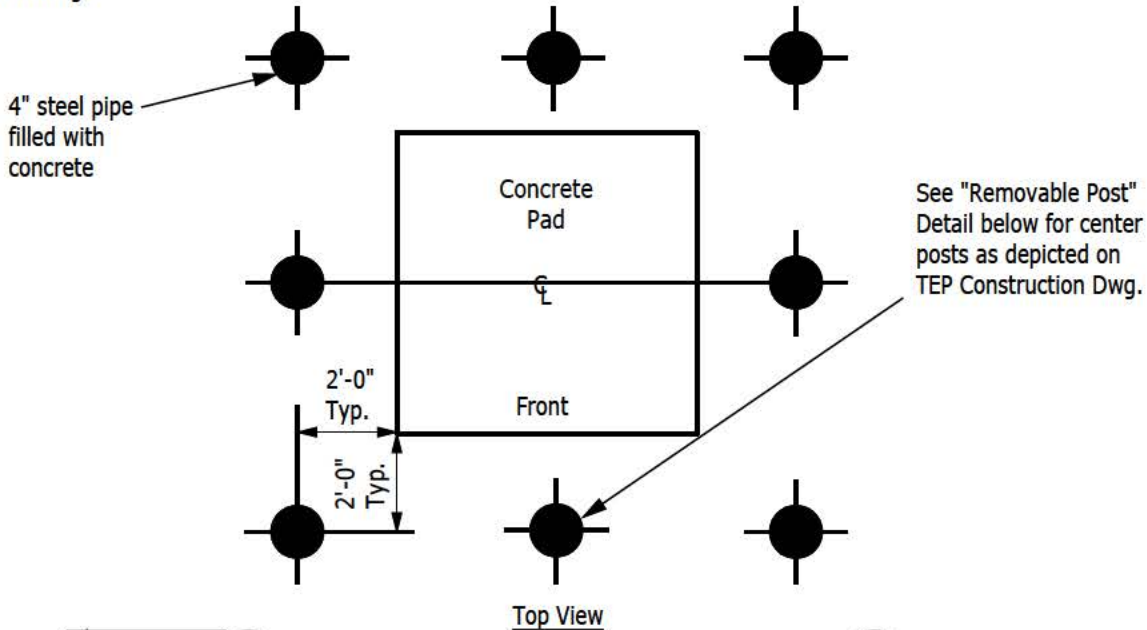

4" removable post not to be concrete filled. Top of post shall be permanently capped.

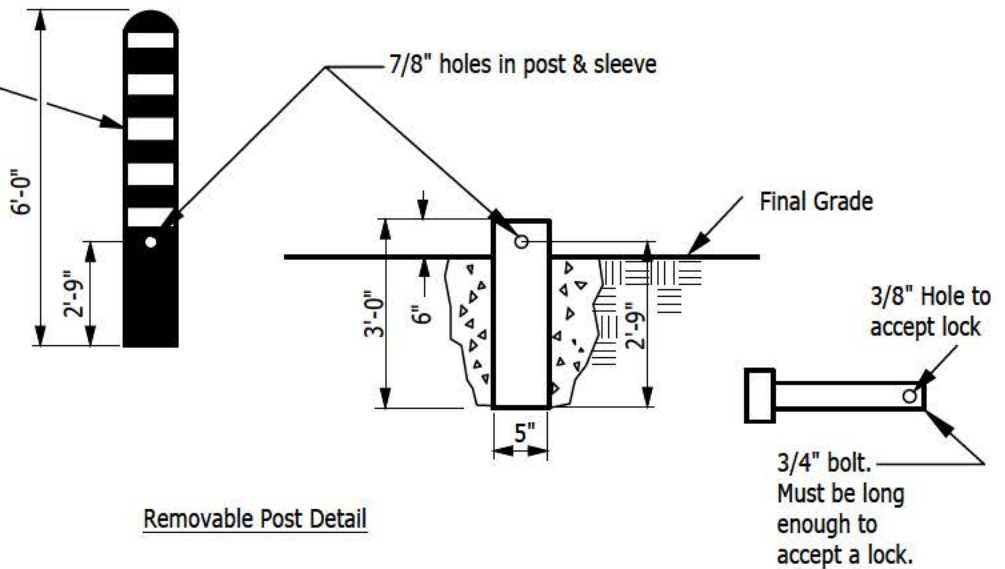

Paint: All pipe surfaces to have one prime coat of Red Oxide and one finish coat of dull black enamel.



Tape: Yellow Reflective tape, 4" wide.

USE: CUSTOMER INSTALLED TRANSFORMER BOX PAD, SINGLE PHASE
 SINGLE-PHASE
 TRANSFORMER BOX PAD
 25KVA - 75KVA



NOTES:

1. Refer to SR-209 for trench detail and placement of equipment within easements.
2. Customer is to provide property pins and/or swing ties (stakes) to the center of equipment. These pins/stakes must be in place for the trench/conduit and backfill/mandrel inspections.
3. Pad and trench sites shall be level and at final grade before calling Design Services for a trench/duct inspection. Driven ground rod to be 20 inches above basement grade and have an impalement cover installed. Ground Rods are Not Permitted to be cut under any circumstance. If soil conditions prohibit driving the ground rod per the SR, contact Design Services.
4. Customer to utilize an approved conduit template available for purchase from Design Services, during the backfill process to ensure proper conduit and ground rod placement at final grade. Duct plugs are required for all conduits, use of duct tape to close ducts is not approved.
5. The service conduit shall be installed into the transformer box pad at the same time as the primary and/or secondary conduits are installed. All conduits are to be tied up per the equipment detail, and prior to calling for the trench and conduit inspection. Typically, secondary conduits 5 and 6 are used for the service stubs. In cases where no secondary is being installed, conduits 1 and 2 will be used for the service runs.
6. Conduit sweeps into new or existing equipment shall be 2 1/2 inches x 36 inches x 90 degree, Grey PVC Electrical Grade, Schedule 40. Wave-rib conduit is NOT approved to be used for new installation into Company equipment.
7. After the conduits (SR-205) and ground rods are in place, the customer is to install a #6 solid soft drawn copper conductor for Telco bonding from the ground rod 2 feet above final grade, 12 inches away from the front of the pad and 36 inches to the right of the pad site. Bury the conductor 12 inches below final grade and coil up approximately 2 feet of conductor. With the template in place, pour concrete cap on the conduit, per SR-205 and 215, Page 2, and call for an inspection. Upon passing the inspection, backfill and compact to 95 percent, level the equipment site and install the transformer box pad. The conduit shall be 4 inches above the basement grade and covered with the appropriate duct plug. See SR-208 for equipment site preparations, including sites with slopes.
8. The customer to call for a transformer box pad site and mandrel inspection.
9. Do not trench under Company owned pad-mounted equipment without Service Provider personnel present. Service Provider's Access Crew can be scheduled to assist with conduit placement and/or trenching required under Company owned equipment. Arrangements must be made by calling 520-918-8300 (TEP) or 520-761-7951 (UES), a minimum of five working days in advance.
10. See SR-207 for bedding and backfill requirements.
11. Company inspectors do not verify grade stakes. Any adjustments required to grade and/or pad sites due to inaccurate grading, grade changes and/or improper grade establishment at trench or pad sites will be the responsibility of the Developer/Contractor. Any associate costs to correct grade or pad sites and any costs incurred by Service Provider due to a change in surface elevation will be borne by the customer.
12. Refer to SR-108 for Right-of-way and Easement requirements.
13. Overall size and opening of box pad may vary up to several inches, dimensions shown are for reference only. Trench layout and duct placement to be based off of center of equipment.

		INITIATED BY	JAB	REVISION NO.	-	SR-231 Pg. 1 of 2
		ESR COMM.	7-24	ESR COMM.	-	
				EFFECTIVE DATE	9-24	

USE: CUSTOMER INSTALLED
SINGLE-PHASE
TRANSFORMER BOX PAD
25KVA - 75KVA

TRANSFORMER BOX PAD, SINGLE PHASE

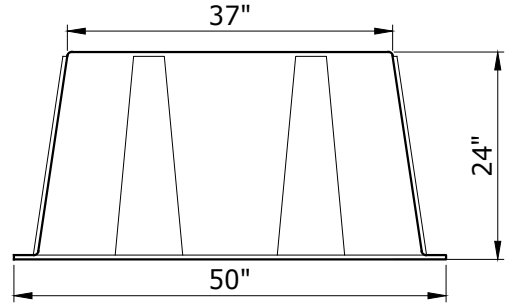
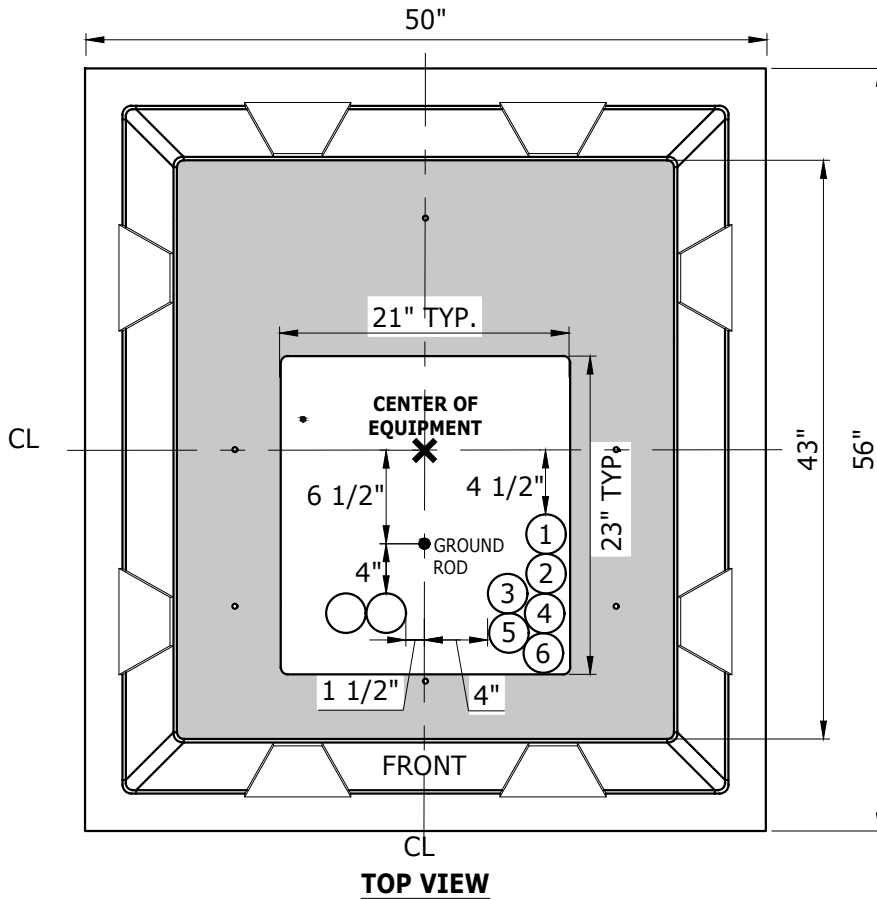

FRONT VIEW

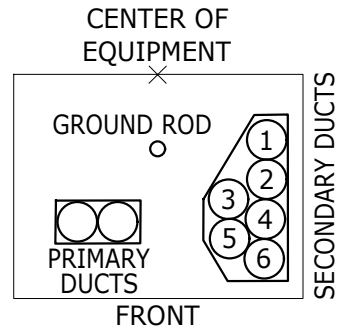

TRANSFORMER TEMPLATE

TRANSFORMER TEMPLATE

- 1** 7-07-1002 - 1 OR 2 SERVICES
- 7-07-1001 - MULTIPLE SECONDARIES OR SERVICES

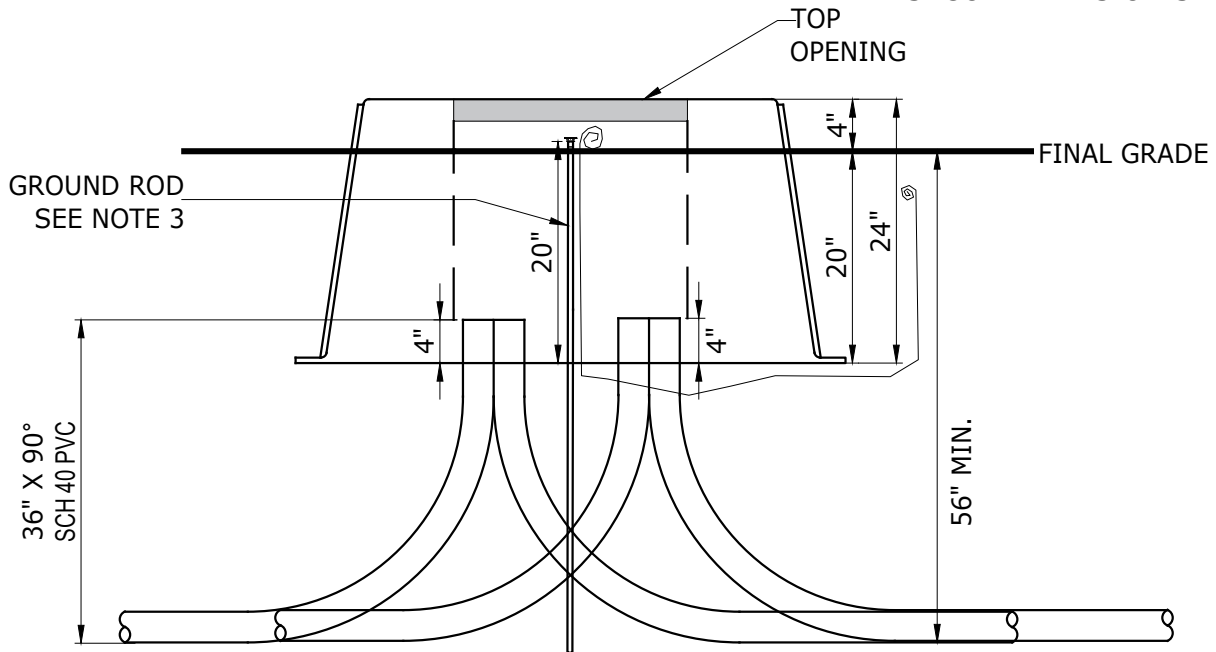

FRONT CIVIL VIEW

3Ø FUSED JUNCTION CABINET (F2) PAD

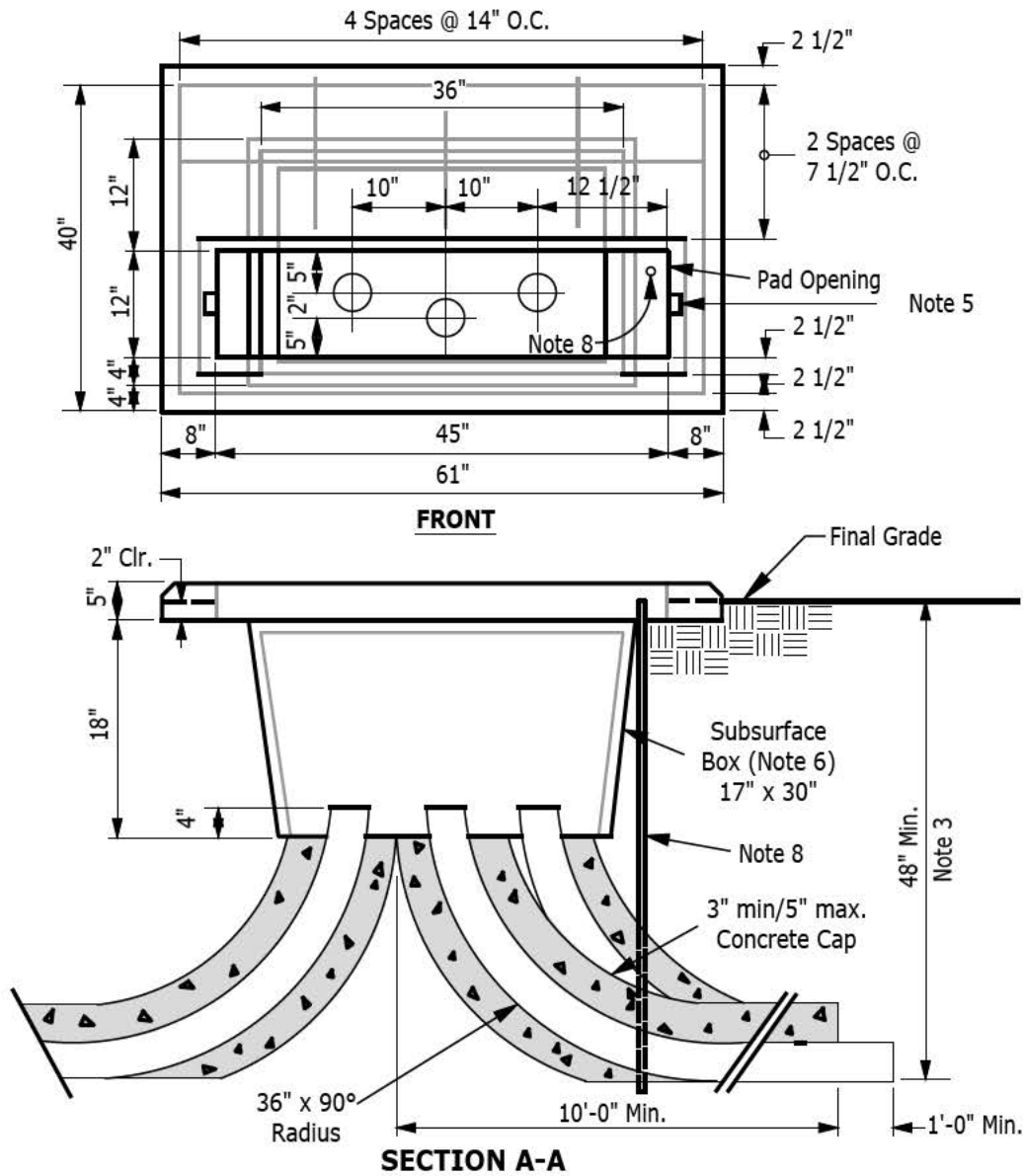

NOTES:

1. All rebar shall be No. 4 and shall be placed so that it does not extend into the pad opening. All concrete and reinforcement shall meet specifications contained in SR-205. The pad surface shall be level and troweled smooth.
2. Unless otherwise specified, all ducts are to be 4 inch and are to be placed according to the dimensions depicted in the above drawing. The duct runs shall be encased in a 3 inch minimum/ 5 inch maximum concrete cap for a minimum distance of 10 ft. measured horizontally from the top of the sweep.
3. Transition from 48 inch depth to 36 inch trench depth to be a gradual slope.
4. F-2 cabinets on pads exposed to vehicular traffic shall have protection installed in accordance with SR-230.
5. (2) 1 5/8" x 2" long concrete insert "Unistrut" tie downs.
6. The F-2 pad may be purchased as a precast concrete pad, if it meets the above specifications and has been approved by TEP. The subsurface box may be precast concrete or plastic.
7. Currently approved pad with subsurface box is: Hayden Conc. Cat. No. SR232.
8. Customer to provide and install a 5/8" x 8'-0" copper coated ground rod prior to concrete being poured. The top of the rod shall be 2 inches below the top of the pad.

USE: CUSTOMER PROVIDED AND INSTALLED EQUIPMENT PAD.

TRANSFORMER AND CAPACITOR PAD, THREE-PHASE



APPROVED PRECAST CONCRETE PAD

FIGURE 1 PAD



USE: TRANSFORMER MAINTENANCE
APPROXIMATE WEIGHT 3,200 LBS.

FIGURE 2 PAD



USE: 75 KVA THRU 2500 KVA TRANSFORMER
APPROXIMATE WEIGHT 5,600 LBS.

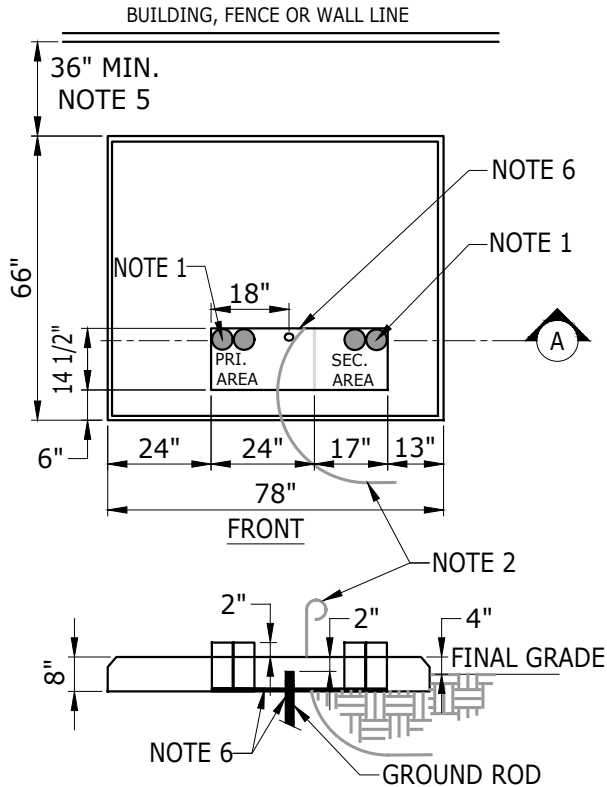

SECTION A, FIG 1.

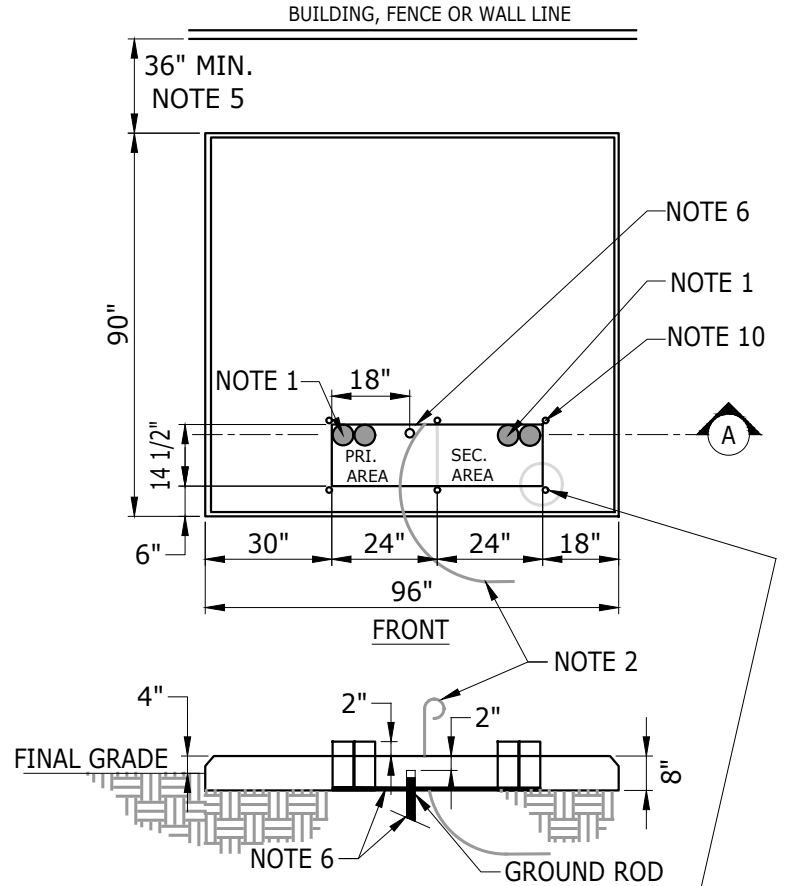

SECTION A, FIG 2.

CAPACITOR DETAIL

SEE SR-241 FOR CIVIL REQUIREMENTS

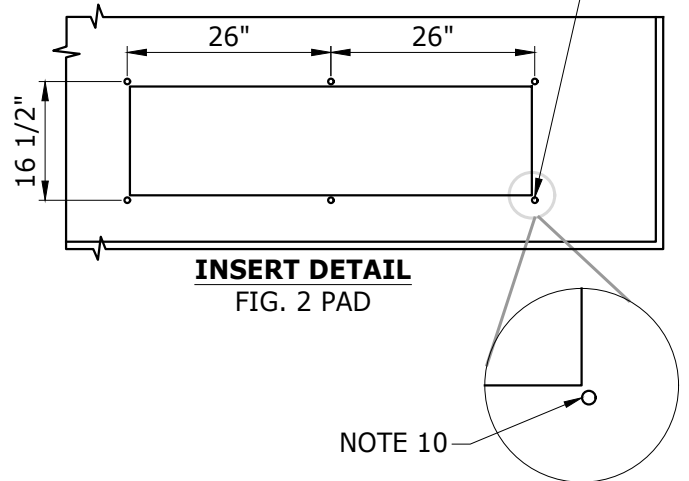
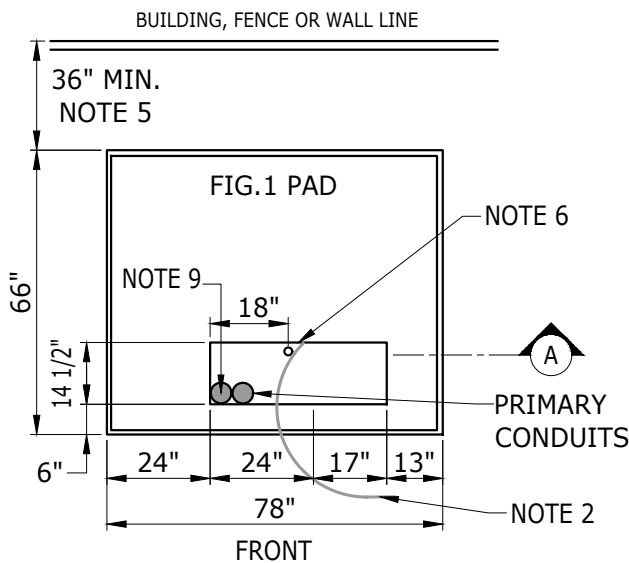

**INSERT DETAIL
FIG. 2 PAD**

TRANSFORMER AND CAPACITOR PAD, THREE-PHASE



NOTES:

1. Place primary ducts as far to the left and to the rear of the primary area as possible and secondary duct(s) as far to the right and to the rear of the secondary area as possible (as viewed from the front of the pad). All ducts to be cut off 2 inches above the top of the pad. Unless otherwise specified, primary ducts shall be 4 inches and shall enter transformer pad with a 36 inch x 90 degree radius PVC sweep. This primary duct run shall be a minimum of 36 inches deep and shall be encased with a 3 inch minimum / 5 inch maximum concrete cap for a minimum distance of 10 feet, measured horizontally from the top of the sweep. Concrete encasement required only on vertical sweeps if duct run is more than 150 feet in length or any length with a combination of 270 degrees (or more) of bends, check with the Design Services. Secondary duct(s) shall be PVC no larger than 4 inches.
2. Install a #6 Cu. conductor for Telco bonding from the center front primary and secondary duct opening to a point 12 inches in front of pad and in line with right edge, 12 inches below final grade. Leave at least 2 feet of #6 Cu. conductor above top of pad.
3. Customer owned service conductor shall not be installed prior to setting of the company transformer. When service conductor is installed, conductor(s) shall extend to the top of the interior of the transformer to allow for cable termination. Each service (every neutral conductor) is to be identified with an address tag at the transformer location. Example, DYMO aluminum embossing strip or other approved method. Identify parallel conductors to assure proper connection, 1 foot above top of pad. **Service conductors are to be no greater than 600kcmil.**
4. Transformers on pads exposed to vehicular traffic or as noted on the Service Provider's Construction Drawing shall have protective barriers installed in accordance with SR-230.
5. The rear edge and the sides of the transformer pad shall be no closer than 3 feet to any building, wall, fence, or other above grade installation, and no structure of any kind shall overhang the pad and/or easement.
6. Customer to provide and install a 5/8" x 8'-0" copper coated ground rod 2 inches below the top of the pad, and with 1/2 inch of mortar slurry mix in the pad opening. Driven ground rod to be within 6 inches of final grade (NESC 094B2). Ground rods are NOT PERMITTED to be cut under any circumstance. If soil conditions prohibit driving the ground rod, contact Design Services, prior to making any deviation from this standard.
7. Customer to provide and install transformer pad(s) per the Service Provider's Construction Drawing. Refer to TABLE 1 for approved manufacturers for pad purchase. The transformer pad(s) are to be free of structural defects and installed level. All rebar shall be No. 4 and shall be placed so that it does not extend into the primary and secondary duct opening. All concrete and reinforcement shall meet specifications contained in SR-205. The pad surface shall be level and troweled smooth. All edges must be chamfered. Poured in place concrete pads are not allowed.

TABLE 1 - APPROVED PADS		
MANUFACTURER	FIGURE 1 CATALOG NO.	FIGURE 2 CATALOG NO.
HAYDEN	P-6-56	P-8-758
JENSEN	SR-233A	SR-233B
OLDCASTLE	SR233-1	SR233-2

8. See SR-208 for site preparation for equipment pads on sloping grades and for screen wall enclosures.
9. Place primary ducts as far to the left and to the front of the primary area as possible (as viewed from the front of the pad). All ducts to be cut off 2 inches above the top of the pad. Unless otherwise specified, primary ducts shall be 4 inches and shall enter transformer pad with a 36 inch x 90 degree radius PVC sweep. See SR-241 for the Capacitor Civil Installation.
10. Figure 2 pads are to have six (6) zinc plated or equivalent steel inserts that are 3/8" x 1 1/4" in length installed by the approved manufactures, as detailed on Page 1.
11. For existing transformer pads, when a transformer is being replaced due to an upgrade, Design Services will determine if the new transformer will fit on the existing pad or if a new pad will be required.



USE: Customer
provided and
installed J-2 base

EXCAVATION AND DUCT PLACEMENT FOR THREE PHASE JUNCTION CABINET (J2)



NOTES:



1. The junction cabinet base is an integral part of the cabinet and shall be provided, installed and backfilled by the Customer. Approved bases must be utilized.

Armorcast Cat. No. A6001475

CDR Systems Group Cat. No. EFBG-206118-1055H-456

Cooper Power Systems Cat. No. 450LOOK03G

Highline Products Cat. No. FGS601818AA-99

Hubbell Cat. No. BG2061181055601

2. Excavation for installation of box pad shall be 77" x 36" x 16" deep. Soil shall be compacted and level prior to box pad placement.
3. Customer to provide and install 4 inch duct and four- 36" x 90 degree radius PVC duct sweeps as depicted on the construction drawing provided by Design Services. Future ducts are to be extended one foot beyond the concrete encasement to allow for future attachment.
4. Front of the cabinet is identified as the side from which the cabinet will open and will be indicated on the construction drawing. Refer to the construction drawing for the direction of conduit placement.
5. See SR-209 for trench and bend requirements.
6. All ducts require 3 inch minimum to 5 inch maximum concrete cap within 10 feet of the box pad. See SR-205 for duct and concrete requirements.
7. See SR-207 for the trench backfill requirements.
8. Installation of equipment protective barriers per SR-230 will be required (refer to construction drawing) where cabinet is exposed to vehicular traffic or as determined by Design Services.
9. A gradual transition slope from the 36 inch trench depth to the 48 inch box pad trench depth is required.



10. Customer to provide and install a 5/8" x 8'-0", copper clad ground rod prior to concrete encasement. The top 6 inches shall extend above the sub-grade within the opening of the box pad. See the diagrams for placement information. Ground rods are NOT PERMITTED to be cut under any circumstance. If soil conditions prohibit driving the ground rod, contact Design Services prior to making an deviation from this standard.
11. If installation of a sweep is required into an existing J2 cabinet, an access crew appointment is required to provide assistance and proper placement. See SR-106 for scheduling information.

		INITIATED BY	SC	REVISION NO.	16	SR-234 Pg. 1 of 2
		ESR COMM.	5-79	ESR COMM.	5-24	
		ESR COMM.	5-79	EFFECTIVE DATE	7-24	

USE: Customer provided and installed J-2 base

EXCAVATION AND DUCT PLACEMENT FOR THREE PHASE JUNCTION CABINET (J2)

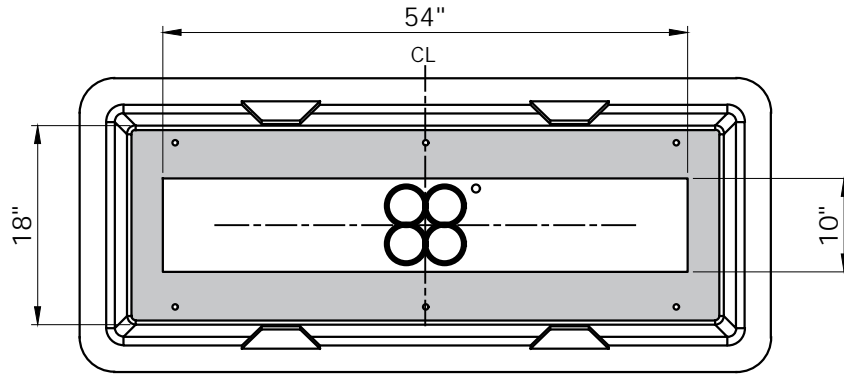

TOP VIEW

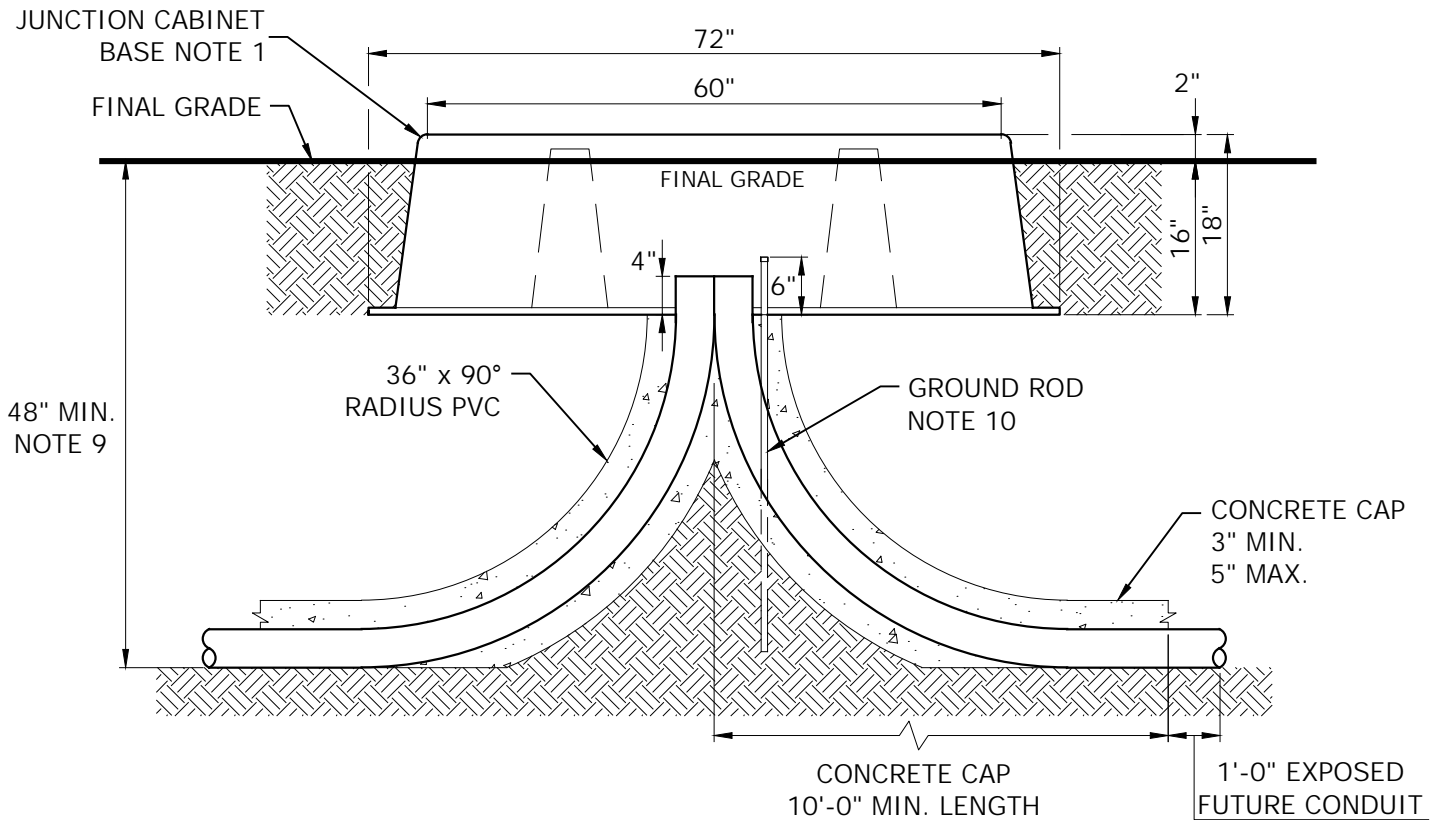

FRONT VIEW

		INITIATED BY	JAB	REVISION NO.	1	SR-234	
		ESR COMM.	5-24	ESR COMM.	-		Pg. 2 of 2
				EFFECTIVE DATE	7-24		

EXCAVATION AND DUCT PLACEMENT FOR 1Ø JUNCTION CABINET (J1)

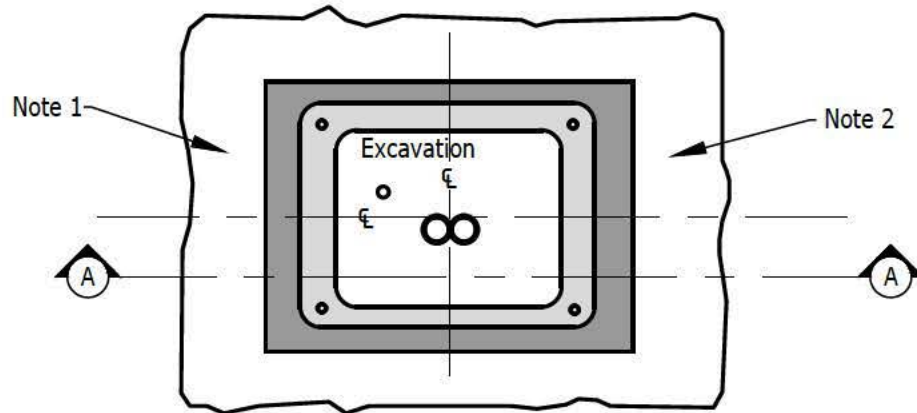

TOP VIEW - JUNCTION CABINET SITE

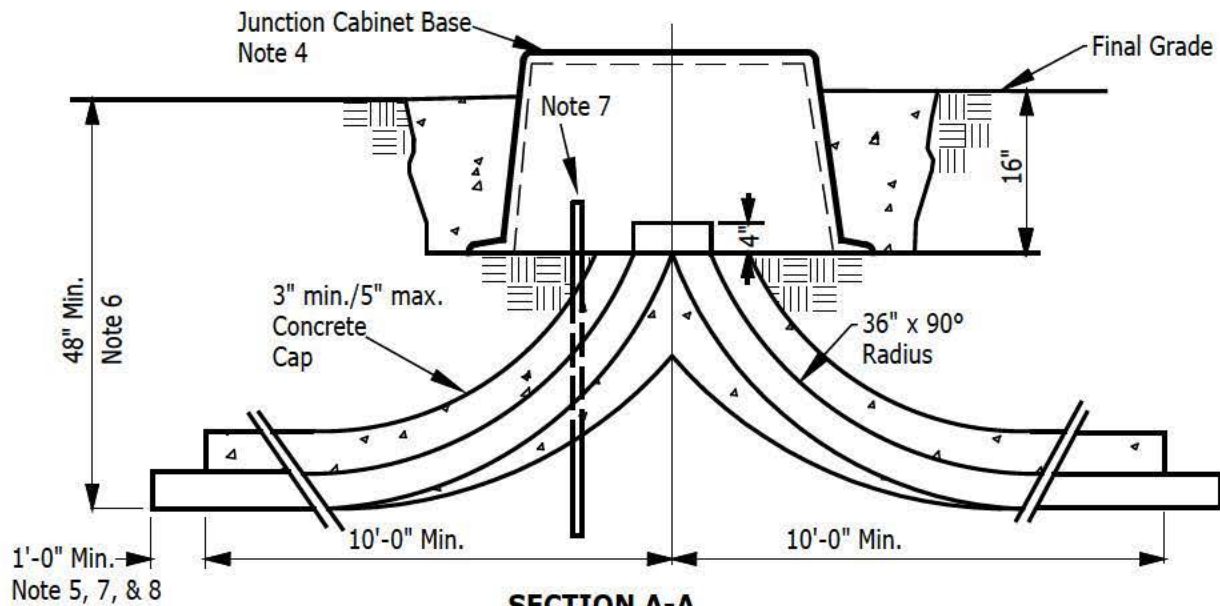

SECTION A-A

NOTES:

1. Customer to provide excavation (36" W x 36" D x 16" Deep) for junction cabinet placement. Soil must be compacted and level. Site preparation per SR-208.
2. See SR-209, Page 5 for placement and trenching, SR-207 for Trench Backfill.
3. Install an equipment protective barrier per SR-230 where cabinet is exposed to vehicular traffic.
4. The junction cabinet base is an integral part of the cabinet and will be provided by TEP and installed and backfilled by the customer. Base to be picked up by customer at District Office.
5. Customer to provide and install the 2 1/2 inch duct run(s) and 2 1/2 inch duct sweep(s) for future duct run(s) as depicted on the TEP construction drawing. Sweeps for future duct runs are to always be placed to the front center of the junction cabinet base excavation (front being the side from which the junction cabinet will open, which will be shown on the construction drawing). Sweeps are to extend 1 ft. beyond their concrete encasement for future attachment.
6. Transition from 48 inch depth to 36 inch trench depth to be a gradual slope.
7. Customer to install a 5/8" x 8'-0" copper coated ground rod prior to concrete being poured. The top of the rod shall be 6 inches above sub-grade. The ground rod shall be provided by TEP.
8. Conduit (duct run or sweeps) only as required, refer to the construction drawing.

USE: Customer provided and installed J-6 base

EXCAVATION AND DUCT PLACEMENT FOR THREE PHASE FEEDER JUNCTION CABINET, 600A (J-6)

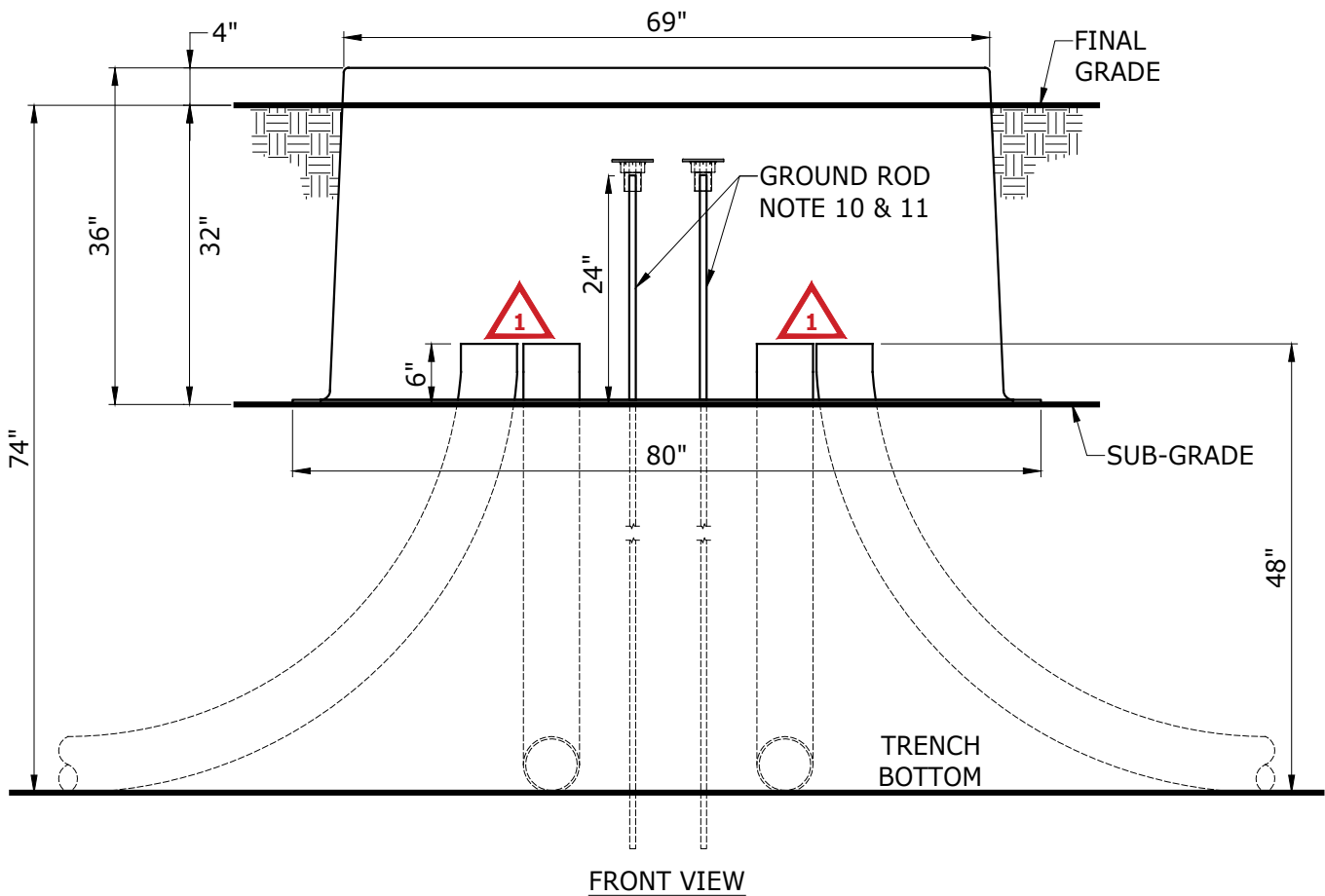
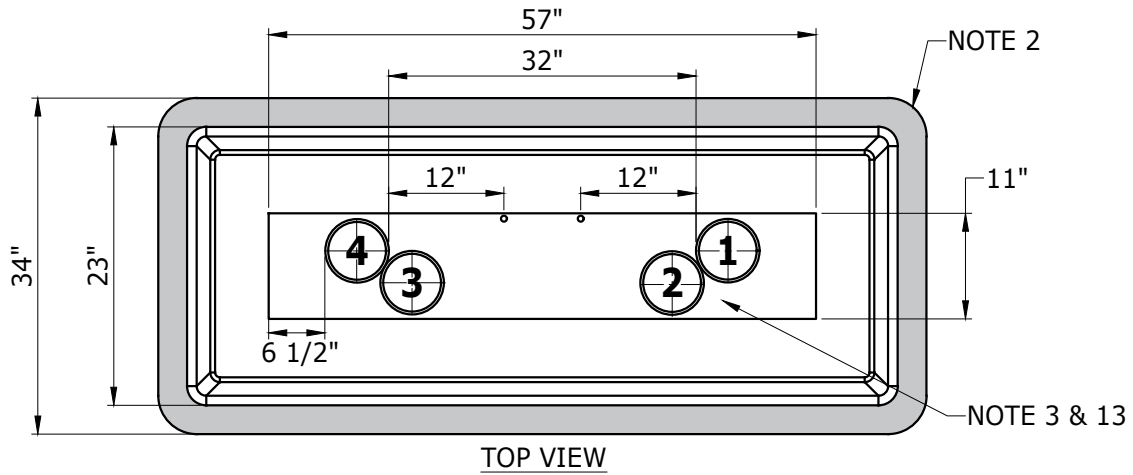

FIGURE 1
J6 CABINET BASE AND DUCT

		INITIATED BY	JAB	REVISION NO.	1	SR-236
		ESR COMM.	10-23	ESR COMM.	10-25	
				EFFECTIVE DATE	10-25	

USE: Customer provided and installed J-6 base

EXCAVATION AND DUCT PLACEMENT FOR THREE PHASE FEEDER JUNCTION CABINET, 600A (J-6)

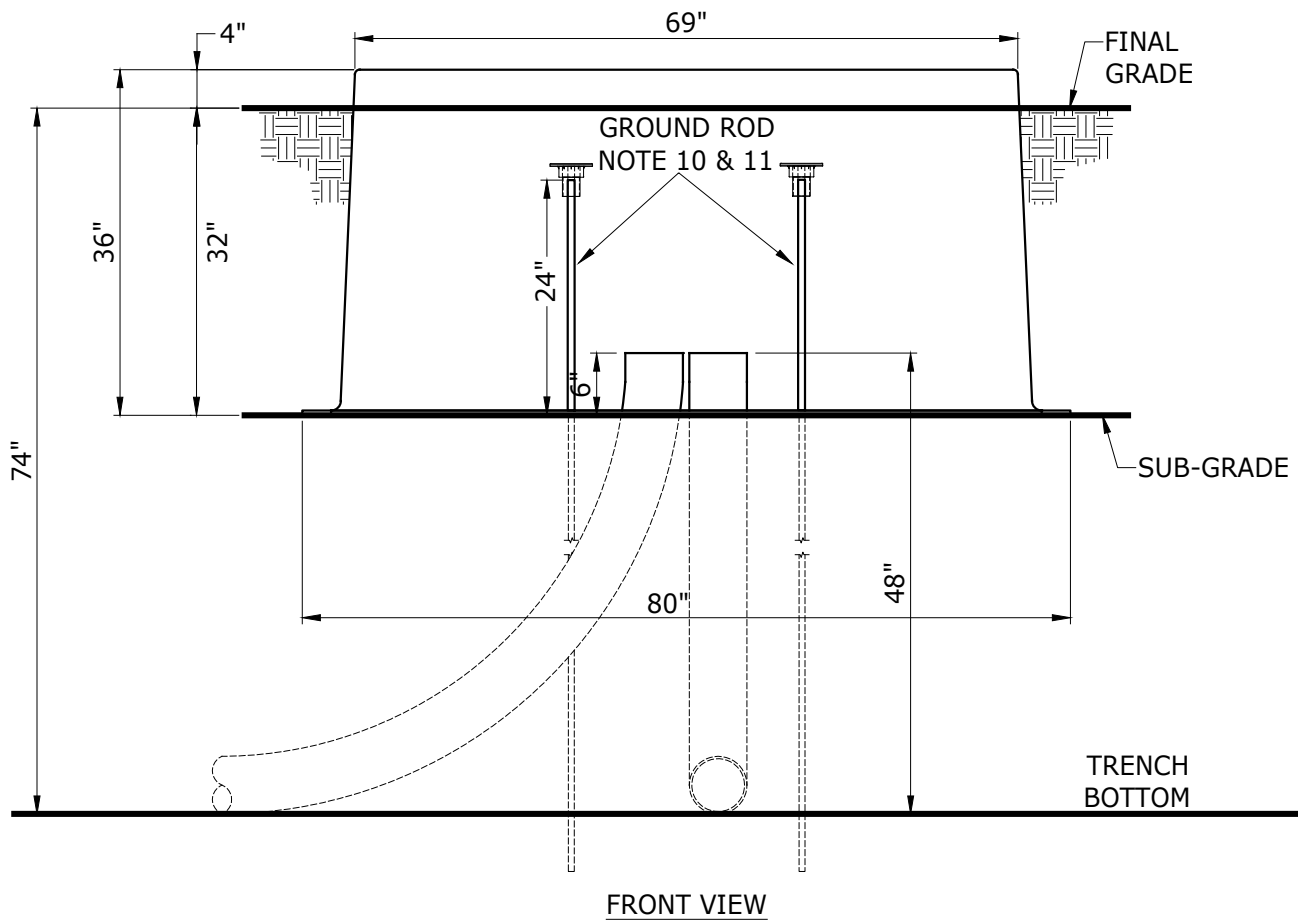
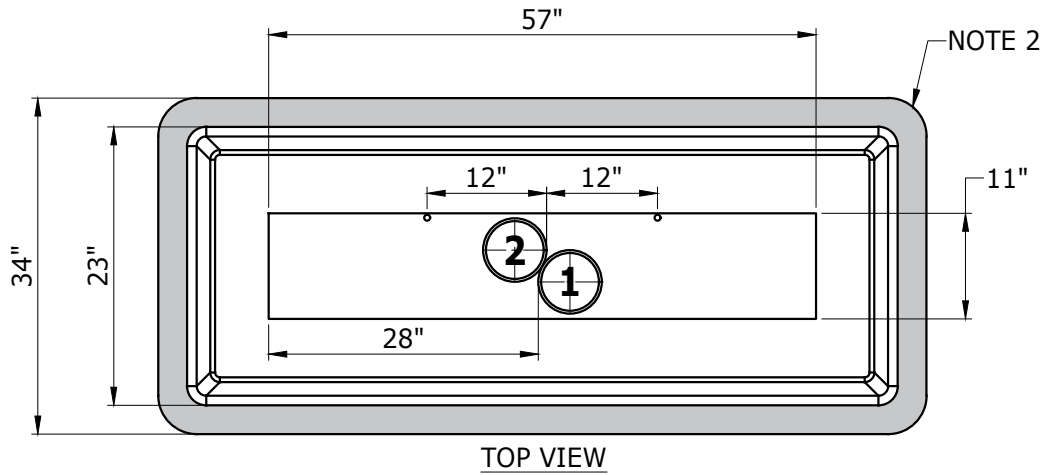

FIGURE 2
SINGLE BUS J6 CABINET BASE AND DUCT

		INITIATED BY	JAB	REVISION NO.	2	SR-236
		ESR COMM.		10-23	ESR COMM.	
				EFFECTIVE DATE	10-25	



USE: Customer provided and installed J-6 base

EXCAVATION AND DUCT PLACEMENT FOR THREE PHASE FEEDER JUNCTION CABINET, 600A (J-6)



NOTES:

1. The junction cabinet base is an integral part of the cabinet and shall be provided, installed and backfilled by the Customer. Approved base must be utilized, Concast, Fibercrete FC box pad, Cat. No. **FC-23-69-36-TEP**.
2. Excavation for installation of box pad shall be 82" x 36" x 32" deep, soil shall be compacted and level prior to box pad placement.
3. Customer to provide and install 6 inch duct and four - 48 inch x 90 degree radius PVC duct sweeps as depicted on construction drawing and detail sheets provided by Design Services. Duct placement shown in Figure 1 is for reference only
4. Front of the cabinet is identified as the side from which the cabinet will open and will be indicated on the construction drawing. Future ducts are to be extended one foot beyond concrete encasement. Refer to the construction drawing for the direction of conduit placement.
5. See SR-215 for the trench and bend requirements.
6. All ducts require 3 inch minimum to 5 inch maximum concrete cap within 10 feet of the box pad. See SR-205 for duct and concrete requirements.
7. See SR-207 for the trench backfill requirements.
8. Installation of equipment protective barriers per SR-230 will be required (refer to construction drawing) where cabinet is exposed to vehicular traffic or as determined by Design Services.
9. A gradual transition slope from the 48 inch trench depth to the 76 inch box pad trench depth is required.
10. Customer to provide and install two- 5/8" x 8'-0", copper clad, ground rods prior to concrete being poured. The top 24 inches of the ground rod shall extend above the sub-grade within the opening of the box pad. See Figure 1 for placement.
11. Ground rods are to have impalement safety covers, (per Federal OSHA 701(B) and California OSHA #C1718AG and OSHA 1723AG, for rebar #3 and #8).
12. If installation of a sweep is required into an existing J6 cabinet, an access crew appointment is required to provide assistance and proper placement. Refer to SR-106 for scheduling information.
13. Conduit positions 1 and 2 are the default location. When a PME cabinet (SR-240) is installed in conjunction with the J6 cabinet (SR-236), conduit positions 2 and 3 are the default to be routed to the PME cabinet. Refer to construction drawing for details on conduit placement.

		INITIATED BY	TRM	REVISION NO.	0	SR-236 Pg. 3 of 3
		ESR COMM.	10-25	ESR COMM.	-	
			EFFECTIVE DATE	-		

EXCAVATION AND DUCT PLACEMENT FOR SWITCHGEAR BOX PAD (PME) 28

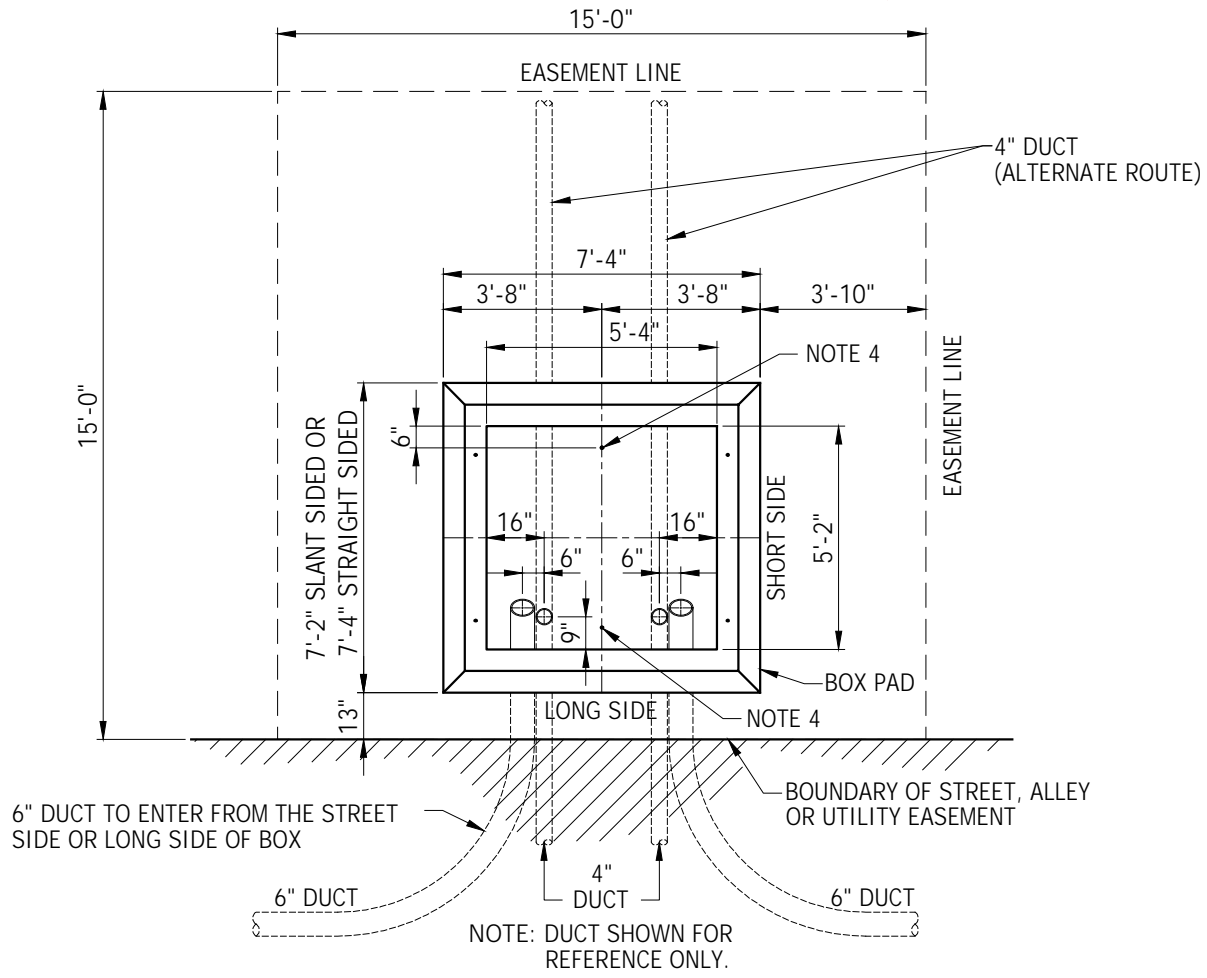

ITEMS TO BE PROVIDED AND INSTALLED BY CUSTOMER

1. ALL DUCTS REQUIRE 3 INCH MINIMUM TO 5 INCH MAXIMUM CONCRETE CAP WITHIN 10 FEET OF BOX PAD, AS SHOWN ON PAGE 2.
2. PRIOR TO SETTING THE BOX PAD, THE BOTTOM OF THE EXCAVATION SHALL CONSIST OF A MINIMUM OF 3 INCHES OF SUITABLE MATERIAL GRADED LEVEL AND COMPACTED TO A MINIMUM RELATIVE DENSITY OF 95% OF MAXIMUM AT OPTIMUM MOISTURE CONTENT. SUITABLE BACKFILL SHALL BE PLACED IN 6 INCH LIFTS TO GRADE. EACH LIFT SHALL BE COMPACTED TO A MINIMUM RELATIVE DENSITY OF 95% OF MAXIMUM AT OPTIMUM MOISTURE CONTENT.
3. BOX PAD - APPROVED MANUFACTURERS:
 - JENSEN PRECAST - SR-240 (CONCRETE) QUAZITE (STRONGWELL) PB74766267B36, 748-1607- TUCSON, AZ.
 - HAYDEN CONCRETE - SR-240 (CONCRETE) 520-682-2566 - TUCSON, AZ.
 - OLDCASTLE PRECAST- 6464 (CONCRETE) 480-963-2678 - CHANDLER, AZ.

NOTE: BOX PAD IS STRAIGHT SIDED, OUTSIDE DIMENSION IS 7'-4" x 7'-4".
4. CUSTOMER TO PROVIDE AND INSTALL (2) 5/8" X 8'-0" GROUND RODS PRIOR TO CONCRETE BEING POURED. THE TOP 12 INCHES OF THE ROD SHALL EXTEND ABOVE SUB-GRADE. THE RODS SHALL BE LOCATED ALONG THE LEFT TO RIGHT CENTER LINE AND 6 INCHES INSIDE OF THE BOX PADS UPPER LIP.
5. TWO (2) IMPALEMENT SAFETY COVERS, (PER FEDERAL OSHA 701 (B) AND CALIFORNIA OSHA #C1718AG AND OSHA 1723AG, FOR REBAR #3 & #8), SHALL BE INSTALLED ON GROUND RODS. REFER TO SUPPLIER BORDER STATES ELECTRIC.

		INITIATED BY	SC	REVISION NO.	28	SR-240 Pg. 1 of 5
		ESR COMM.	8-78	ESR COMM.	2-24	
				EFFECTIVE DATE	2-24	

EXCAVATION AND DUCT PLACEMENT FOR SWITCHGEAR BOX PAD (PME)

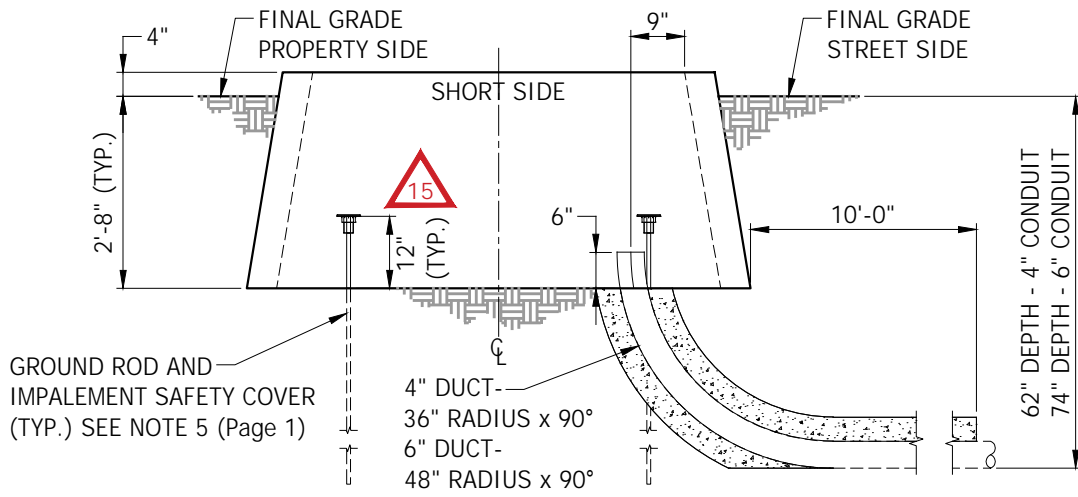

DUCT LOCATION WHEN LEAVING TOWARD STREET/ALLEY/UTILITY EASEMENT
 6" DUCT WITH 90° SWEEP TO BE UTILIZED BY DESIGNERS REQUEST ONLY

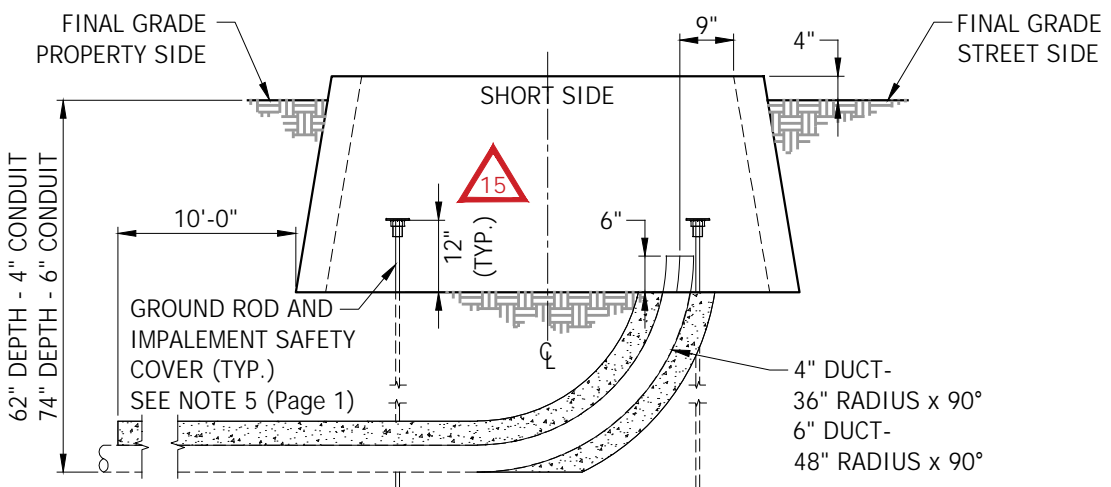

DUCT LOCATION WHEN LEAVING TOWARD PROPERTY 6" DUCT WITH 90° SWEEP TO BE UTILIZED BY DESIGNERS REQUEST ONLY

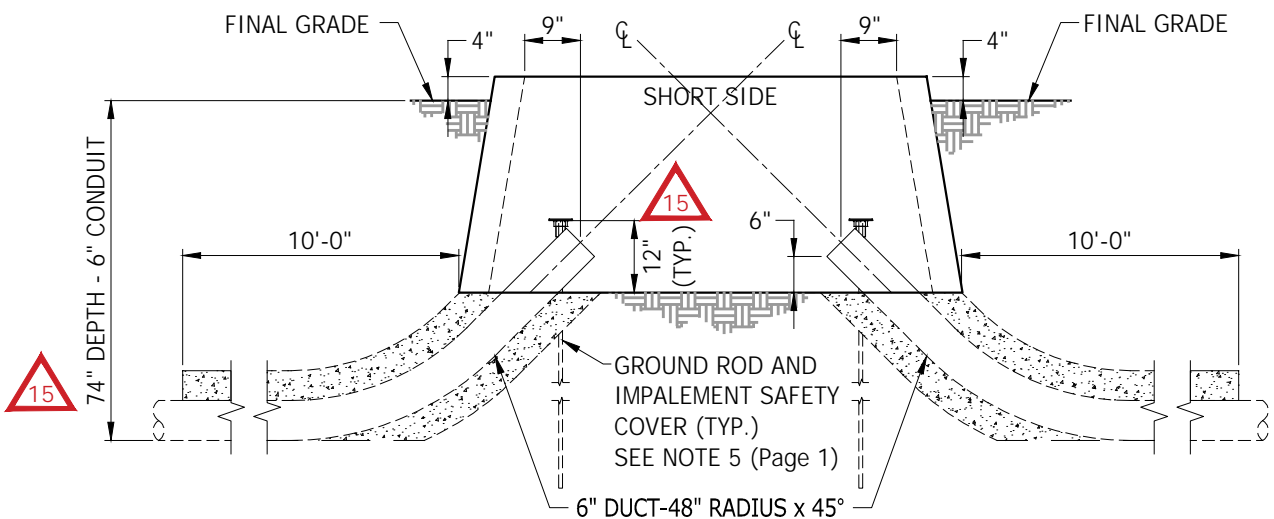

DUCT LOCATION WHEN ENTERING & LEAVING TOWARD STREET/ALLEY/UTILITY EASEMENT

		INITIATED BY	SC	REVISION NO.	15	SR-240	
		ESR COMM.	8-78	ESR COMM.	2-24		Pg. 2 of 5
				EFFECTIVE DATE	2-24		

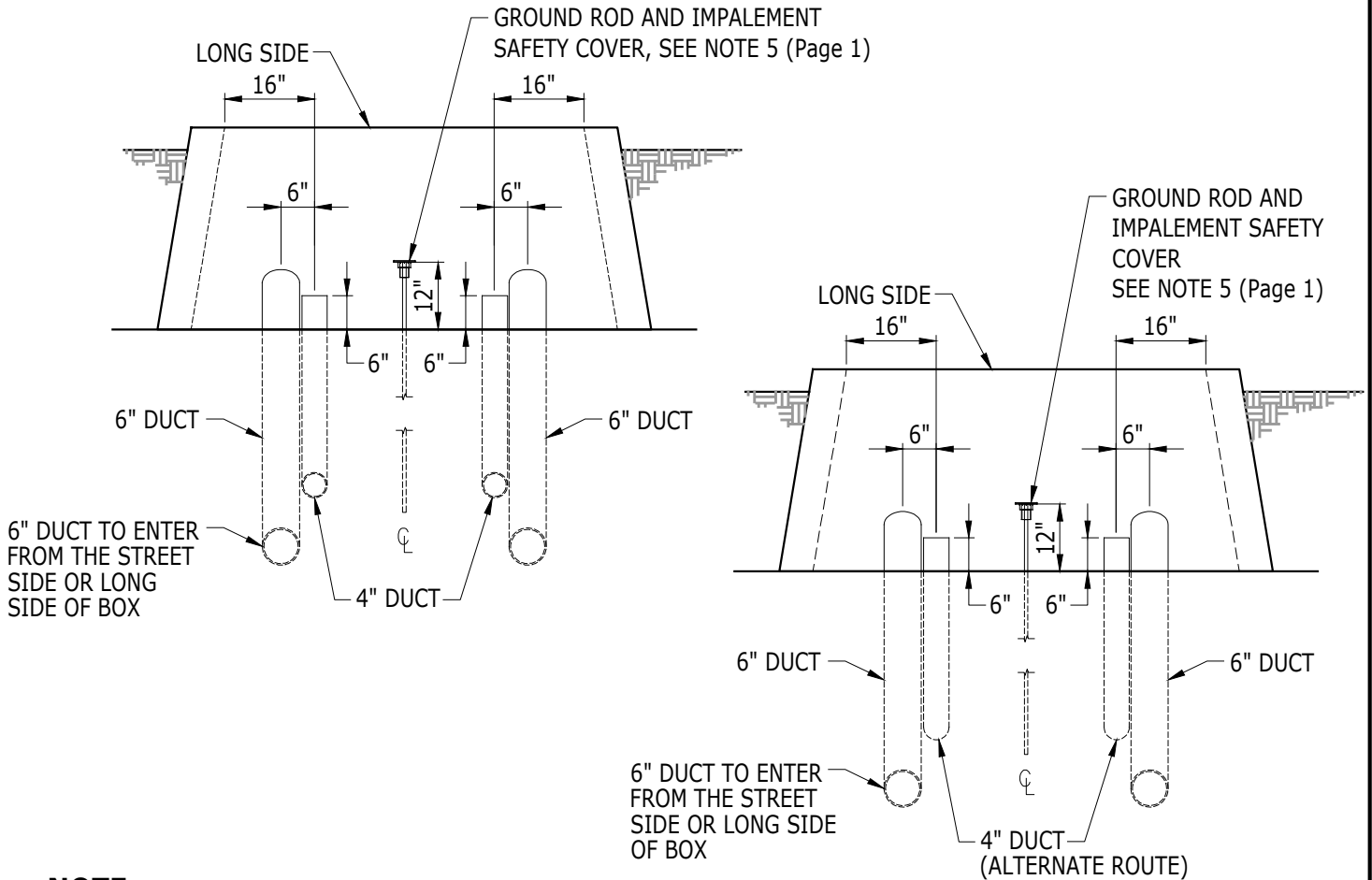
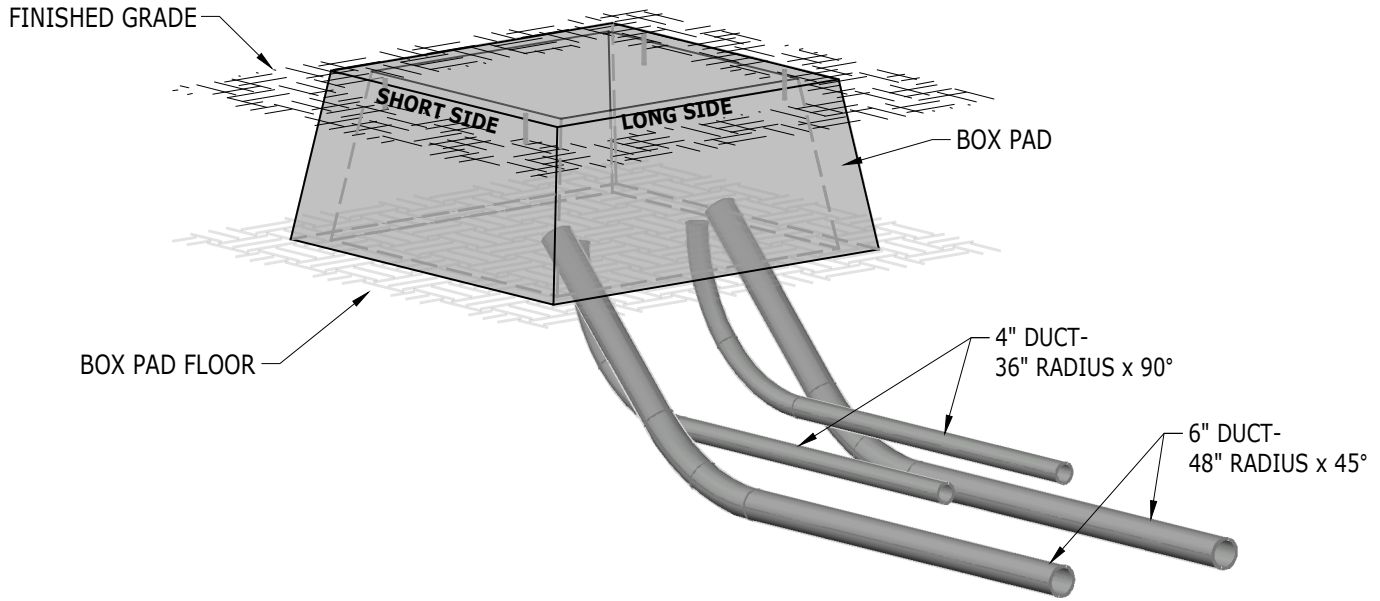

EXCAVATION AND DUCT PLACEMENT FOR SWITCHGEAR BOX PAD (PME)



NOTE:

DUCT SHOWN FOR REFERENCE ONLY. FOR EXACT LOCATION AND DUCT SIZE (INCLUDING SWEEP(S) FOR FUTURE DUCT), SEE CONSTRUCTION DRAWING PREPARED BY DESIGN SERVICES. SWEEPS FOR FUTURE DUCT ARE TO BE EXTENDED ONE FOOT BEYOND THEIR CONCRETE ENCASEMENT FOR FUTURE ATTACHMENT.



		INITIATED BY	SC	REVISION NO.	11	SR-240 Pg. 3 of 5
		ESR COMM.	10-91	ESR COMM.	2-24	
				EFFECTIVE DATE	7-24	

EXCAVATION AND DUCT PLACEMENT
FOR SWITCHGEAR BOX PAD (PME)

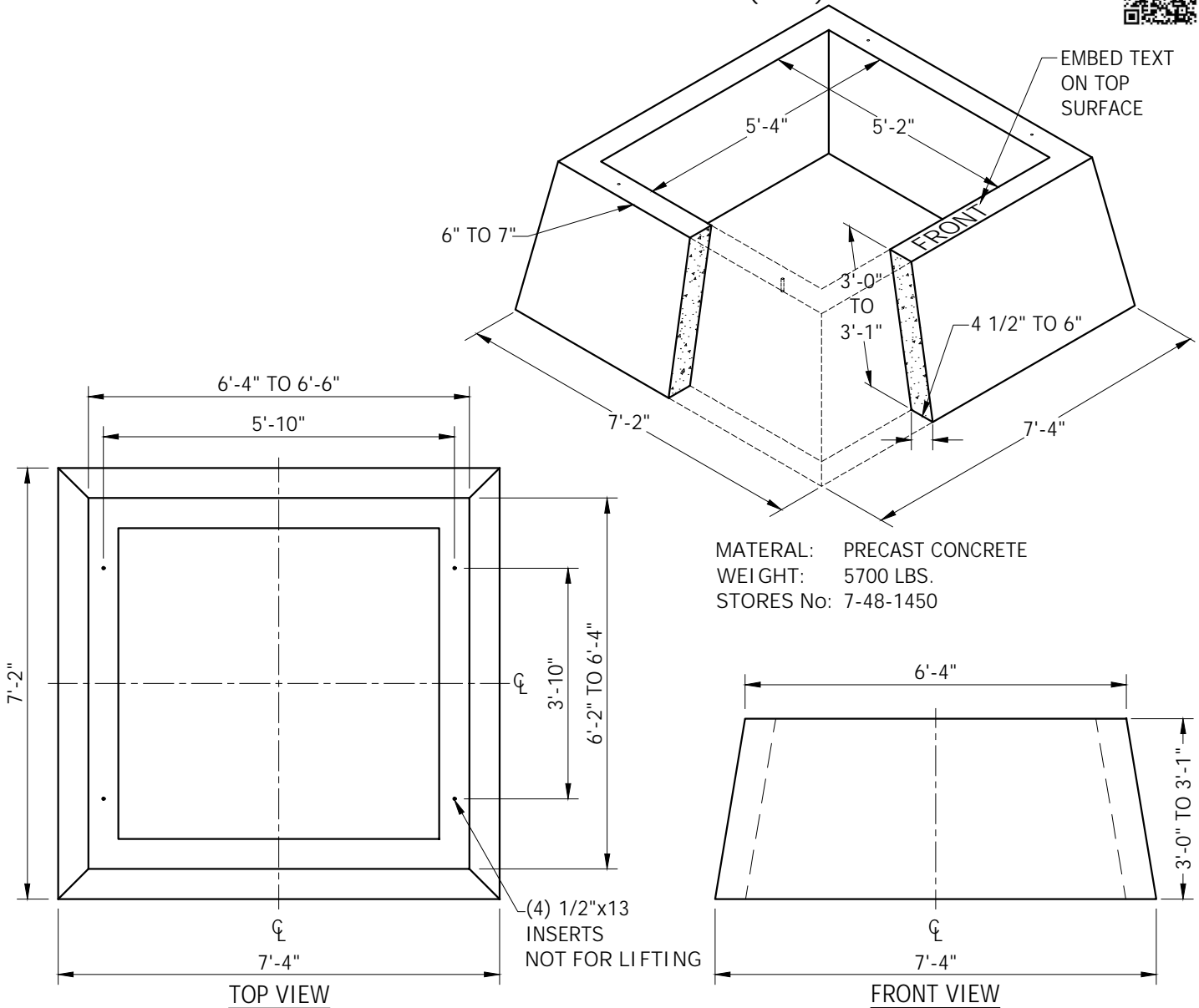

NOTE:

1. MANUFACTURER TO CHAMFER INSIDE AND OUTSIDE EDGES AT 45 DEGREES.

IMPALEMENT SAFETY COVER

SEE NOTE 5 (Page 1)

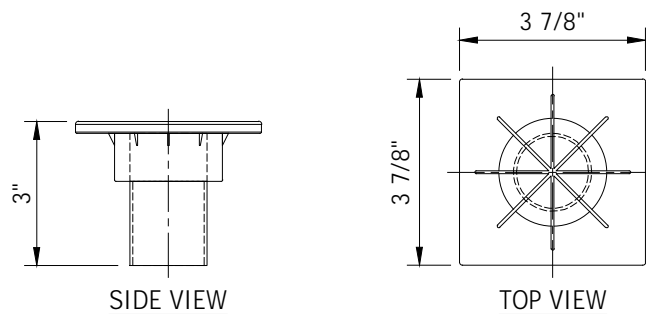

EXCAVATION AND DUCT PLACEMENT
FOR SWITCHGEAR BOX PAD (PME) 



EMBED TEXT ON
TOP SURFACE

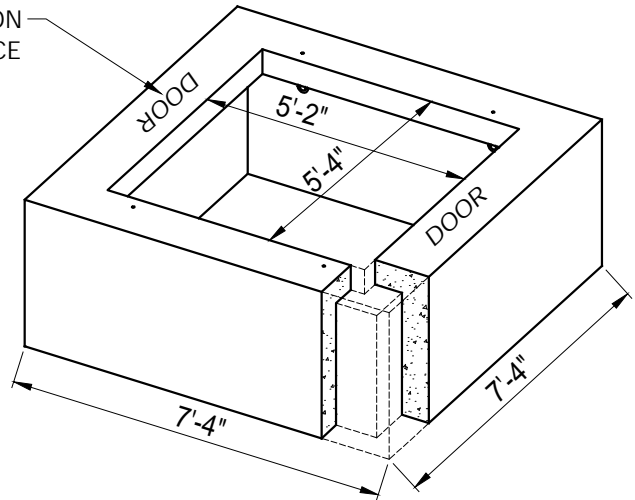

MATERIAL: PRECAST CONCRETE
(STRAIGHT SIDED)

WEIGHT: 7100 LBS.

STORES No: 7-48-1450

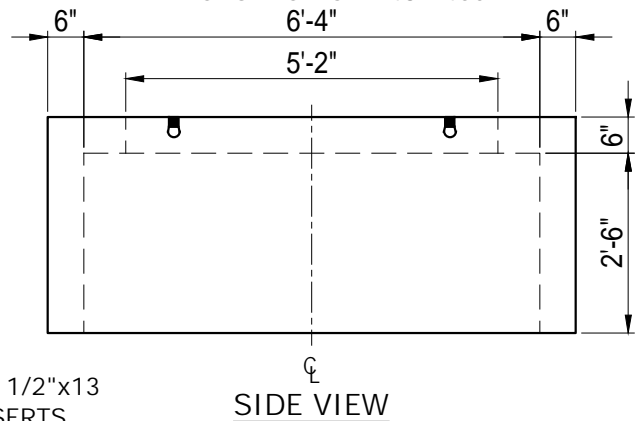
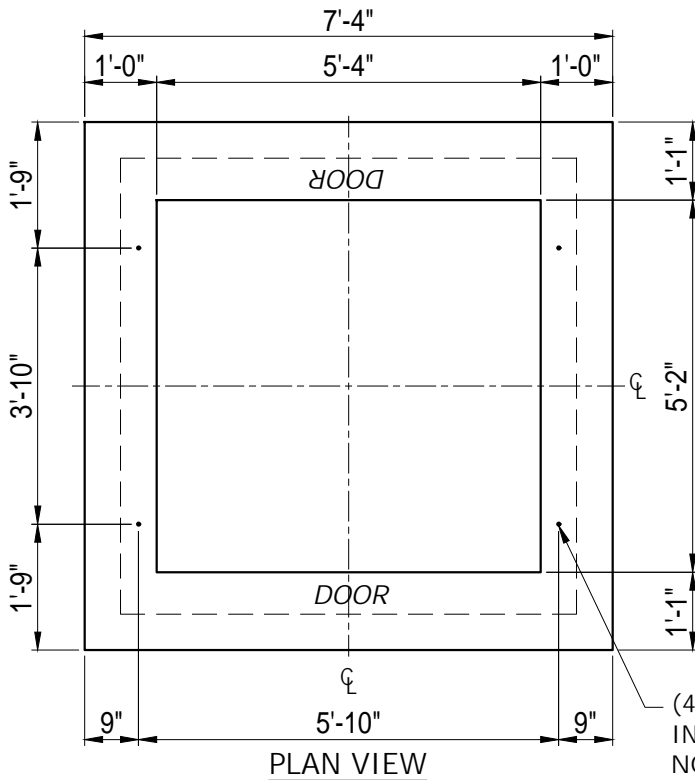

NOTE:

1. MANUFACTURER TO CHAMFER INSIDE AND OUTSIDE EDGES AT 45 DEGREES.

IMPALEMENT SAFETY COVER

SEE NOTE 5 (Page 1)

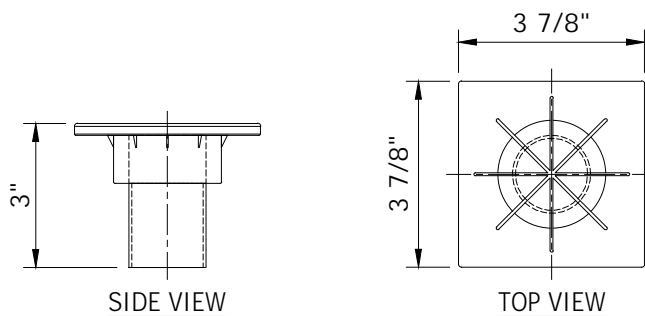

EXCAVATION AND DUCT PLACEMENT FOR PAD-MOUNTED CAPACITOR

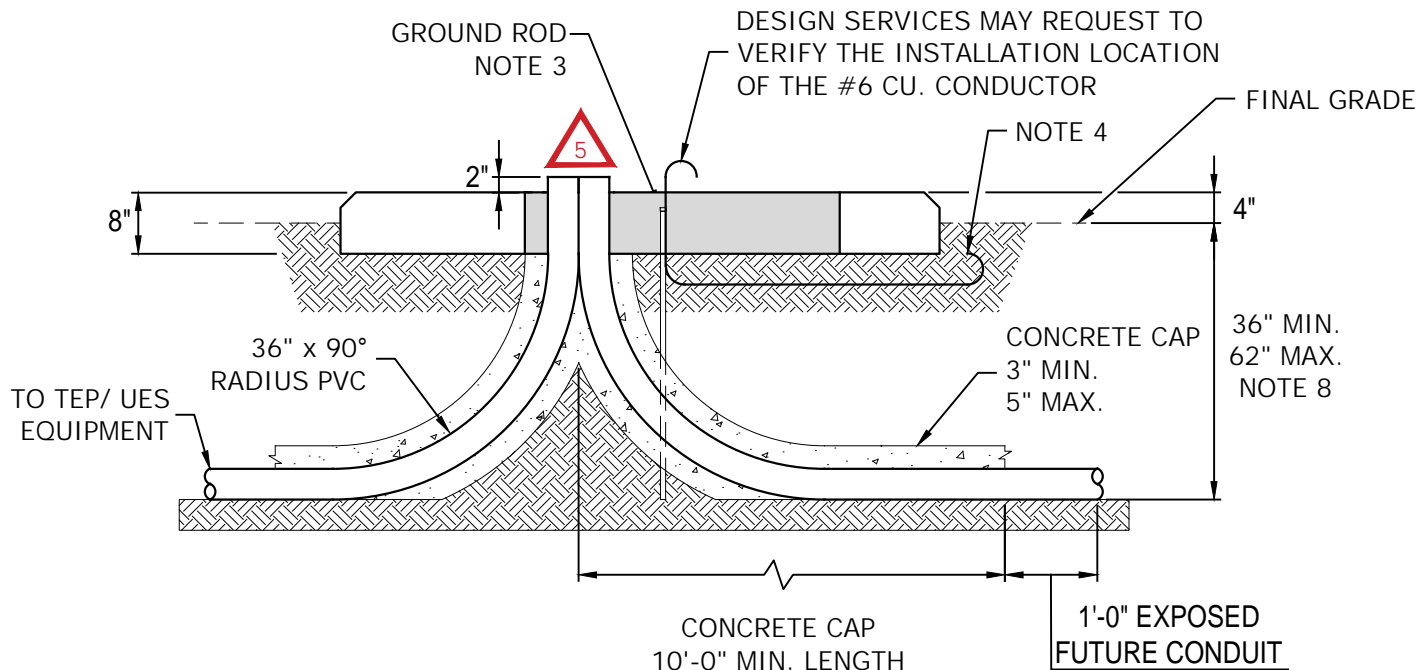

NOTES:

1. CUSTOMER TO EXCAVATE PER SR-215 FOR THE INSTALLATION OF A 4 INCH CONDUIT SYSTEM.
2. CUSTOMER TO PROVIDE AND INSTALL THE 4 INCH CONDUIT SYSTEM AND CONDUIT SWEEP WITH STUB FOR FUTURE USE AS DEPICTED ON THE COMPANY CONSTRUCTION DRAWING. CONDUIT STUBS ARE TO BE EXTENDED ONE FOOT BEYOND THEIR CONCRETE ENCASEMENT FOR FUTURE ATTACHMENT. SEE SR-205 FOR THE APPROVED CONDUIT AND CONCRETE INSTALLATION. SEE SR-218 FOR THE STUB INSTALLATION.
3. CUSTOMER TO PROVIDE AND INSTALL A 5/8" X 8' COPPER COATED GROUND ROD 2 INCHES BELOW THE TOP OF THE PAD WITH 1/2 INCH MORTAR SLURRY IN THE PAD OPENING. DRIVEN GROUND ROD TO BE WITHIN 6 INCH OF FINAL GRADE (NESC 094B2).
NOTE: GROUND RODS ARE NOT PERMITTED TO BE CUT UNDER ANY CIRCUMSTANCE. IF SOIL CONDITIONS PROHIBIT DRIVING THE GROUND ROD, CONTACT DESIGN SERVICES FOR REVIEW.
4. CUSTOMER TO PROVIDE AND INSTALL A #6 CU. CONDUCTOR FOR TELCO BONDING FROM THE CENTER FRONT PRIMARY DUCT OPENING TO A POINT 12 INCHES IN FRONT OF PAD, IN LINE WITH RIGHT EDGE AND 12 INCHES BELOW FINAL GRADE. LEAVE A MINIMUM OF 2 FEET OF #6 CONDUCTOR ABOVE TOP OF PAD.
5. CUSTOMER TO BACKFILL PER SR-207.
6. CUSTOMER TO PROVIDE AND INSTALL A FIGURE 1 PAD PER SR-233.
7. CUSTOMER TO PROVIDE AND INSTALL EQUIPMENT PROTECTIVE BARRIERS PER SR-230, IF REQUIRED DUE TO EQUIPMENT LOCATION.
8. IF CAPACITOR IS INSTALLED IN CLOSE PROXIMITY TO A PME OR PMH SWITCHGEAR, THE TRENCH DEPTH WILL BE 62 INCHES, SEE SR-240.
9. FOR CONDUIT INSTALLATION INTO EXISTING UNDERGROUND EQUIPMENT, CONTACT ACCESS AT 520-918-8300 (TEP) OR 520-761-7951 (UES). DO NOT TRENCH UNDER SERVICE PROVIDER'S EQUIPMENT WITHOUT THE PRESENCE OF AN ACCESS CREW.
10. SERVICE PROVIDER WILL INSTALL THE PRIMARY CABLE AND PAD MOUNTED CAPACITOR.

3 EXCAVATION AND DUCT PLACEMENT FOR GAS INSULATED SWITCHGEAR BOX PAD (VISTA)

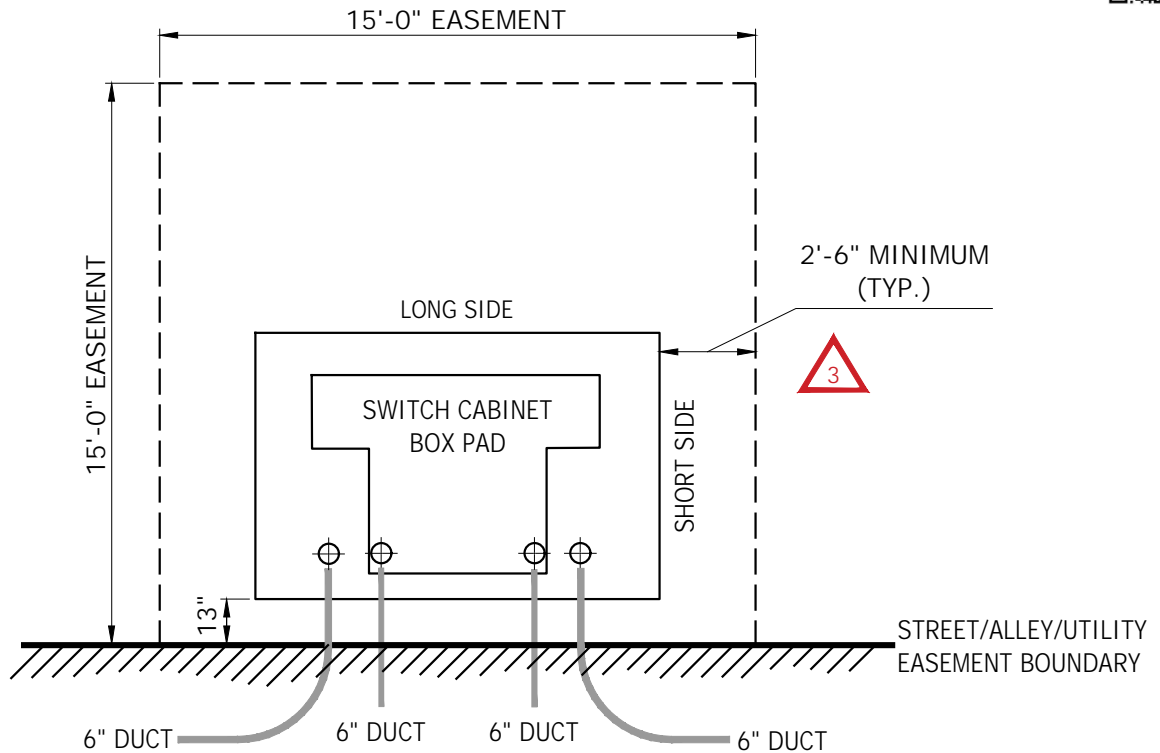

EQUIPMENT PLACEMENT IN TYPICAL EASEMENT

NOTES:

1. ALL DUCTS REQUIRE 3 INCH MINIMUM / 6 INCH MAXIMUM CONCRETE CAP WITHIN 10 FEET OF SWITCH CABINET BASE, AS SHOWN ON PAGE 2.
2. PRIOR TO SETTING THE SWITCH CABINET BASE, THE BOTTOM OF THE EXCAVATION SHALL CONSIST OF A MINIMUM OF 3 INCHES OF SUITABLE MATERIAL GRADED LEVEL AND COMPACTED TO A MINIMUM RELATIVE DENSITY OF 95% RELATIVE TO A STANDARD PROCTOR DENSITY (ASTM D698) OF MAXIMUM AT OPTIMUM MOISTURE CONTENT. SUITABLE BACKFILL SHALL BE PLACED IN 6 INCH LIFTS TO GRADE. EACH LIFT SHALL BE COMPACTED TO A MINIMUM RELATIVE DENSITY OF 95% RELATIVE TO A STANDARD PROCTOR DENSITY (ASTM D698) MAXIMUM AT OPTIMUM MOISTURE CONTENT.

3. SWITCHGEAR BOX PAD APPROVED MANUFACTURERS:

CONCAST INC. CATALOG NO. 422 BASE: FC-69-83-36-V
550 BASE: FC-69-106-36-V



CONTACT BORDER STATES ELECTRIC FOR PURCHASE OF BASE.

4. CUSTOMER TO PROVIDE AND INSTALL (2) 5/8" X 8'-0" GROUND RODS PRIOR TO CONCRETE BEING POURED. THE TOP 12 INCHES OF THE ROD SHALL EXTEND ABOVE SUB-GRADE. THE FIELD TECH SHALL PROVIDE THE PLACEMENT LOCATION.
5. DUCT SHOWN FOR REFERENCE ONLY. FOR EXACT LOCATION AND DUCT SIZE (INCLUDING SWEEPS FOR FUTURE DUCT), SEE CONSTRUCTION DRAWING PREPARED BY THE COMPANY. FUTURE DUCT SWEEPS ARE TO EXTENDED ONE FOOT BEYOND THEIR CONCRETE ENCASEMENT FOR FUTURE ATTACHMENT.



6. SEE PAGES 3 AND 4 FOR CONDUIT AND BASE DETAILS. DUCT TO ENTER FROM THE STREET SIDE OR LONG SIDE OF THE BOX.

		INITIATED BY	MRH	REVISION NO.	3	SR-242 Pg. 1 of 4
		ESR COMM.	7-12	ESR COMM.	2-24	
				EFFECTIVE DATE	2-24	

EXCAVATION AND DUCT PLACEMENT FOR GAS INSULATED SWITCHGEAR BOX PAD (VISTA)

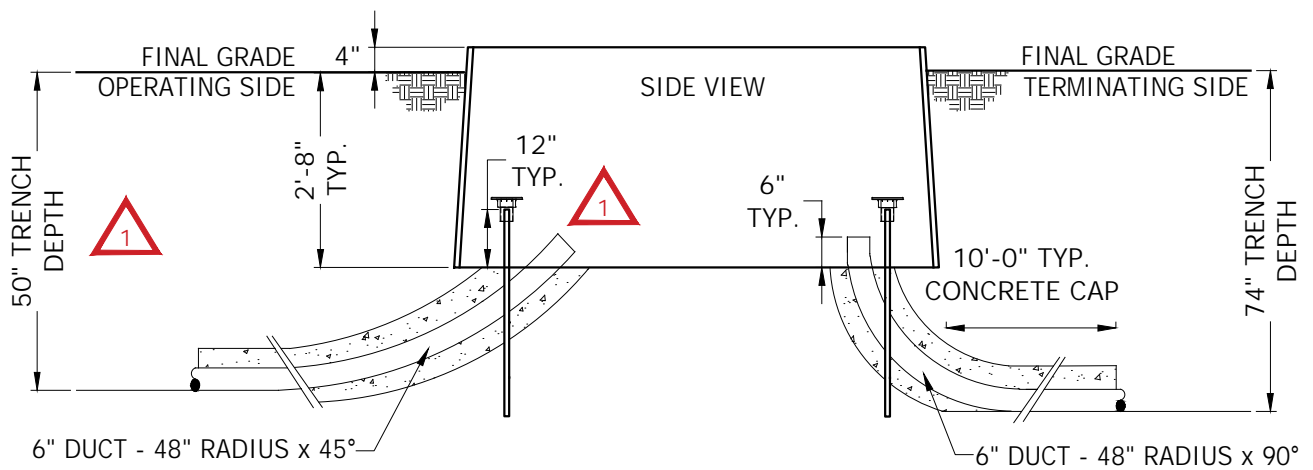

DUCT LOCATION WHEN LEAVING TOWARD STREET/ALLEY/UTILITY EASEMENT

NOTE:
 QUANTITY AND PLACEMENT OF CONDUITS WILL BE DETERMINED BY SERVICE PROVIDER'S DESIGN SERVICES.

		INITIATED BY	MRH	REVISION NO.	1	SR-242 Pg. 2 of 4
		ESR COMM.	7-12	ESR COMM.	2-24	
				EFFECTIVE DATE	2-24	

EXCAVATION AND DUCT PLACEMENT FOR GAS INSULATED SWITCHGEAR BOX PAD (VISTA)



422 BOX PAD

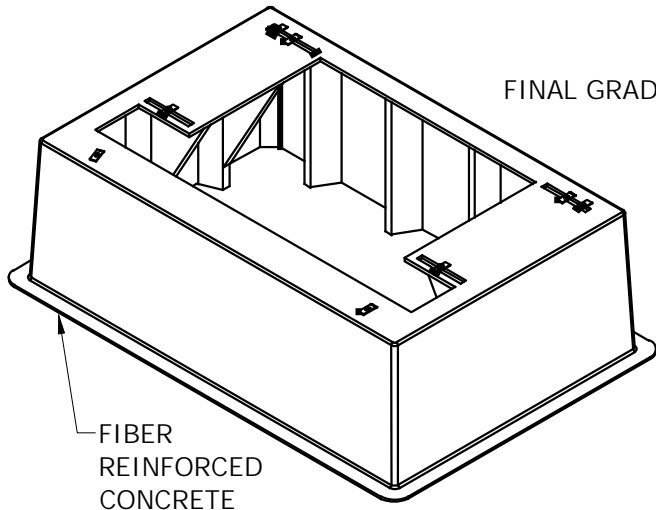

FIBER REINFORCED CONCRETE

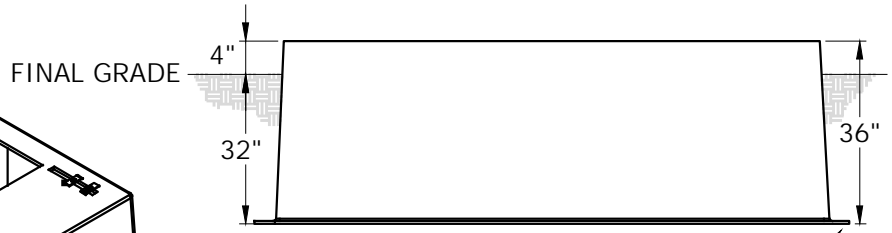

SIDE VIEW

4" FLANGE

APPROVED BOX PAD
CONCAST CATALOG NO.
FC-69-83-36-V

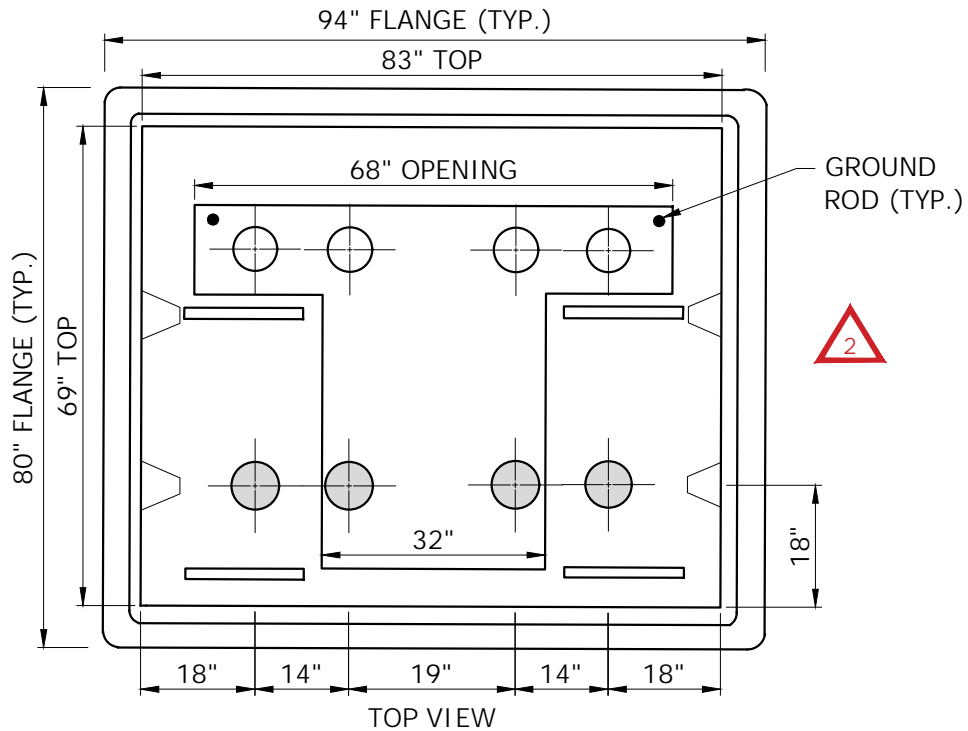

GROUND ROD (TYP.)



TOP VIEW

NOTES:

1. SERVICE PROVIDER'S DESIGN SERVICES TO DETERMINE QUANTITY AND PLACEMENT OF CONDUITS.
2. SHADED DUCT IS PREFERRED LOCATION FOR 48" x 45° SWEEPS.
3. RIGHT SIDE POSITIIONS ARE DESIGNATED FOR FAULT INTERRUPTION.
4. BOX PAD FITS THE FOLLOWING SWITCHGEAR ENCLOSURE SIZES: 61" X 72", 65" x 72" AND 65" x 79".
5. MINIMUM SUBGRADE EXCAVATION DIMENSION IS 32 INCHES.
6. CONTRACTOR TO SCHEDULE A CONDUIT PLACEMENT MEETING WITH DESIGN SERVICES PRIOR TO INSTALLATION.

EXCAVATION AND DUCT PLACEMENT FOR GAS INSULATED SWITCHGEAR BOX PAD (VISTA)



550 BOX PAD

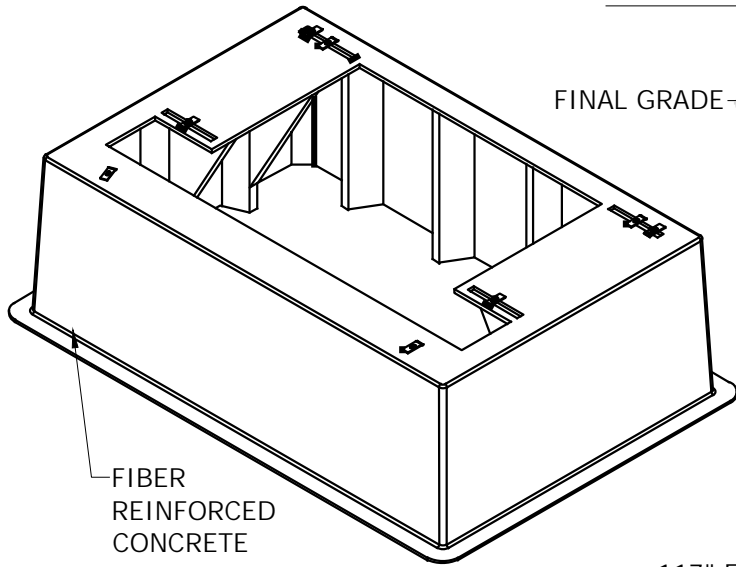

FIBER REINFORCED CONCRETE

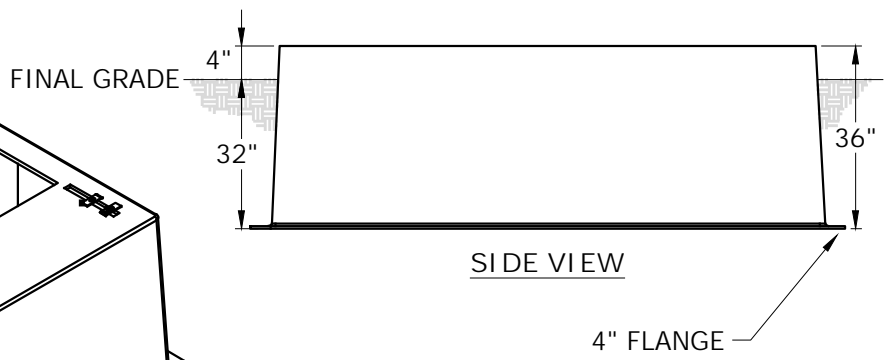

APPROVED BOX PAD:
CONCAST CATALOG NO.
FC-69-106-36-V

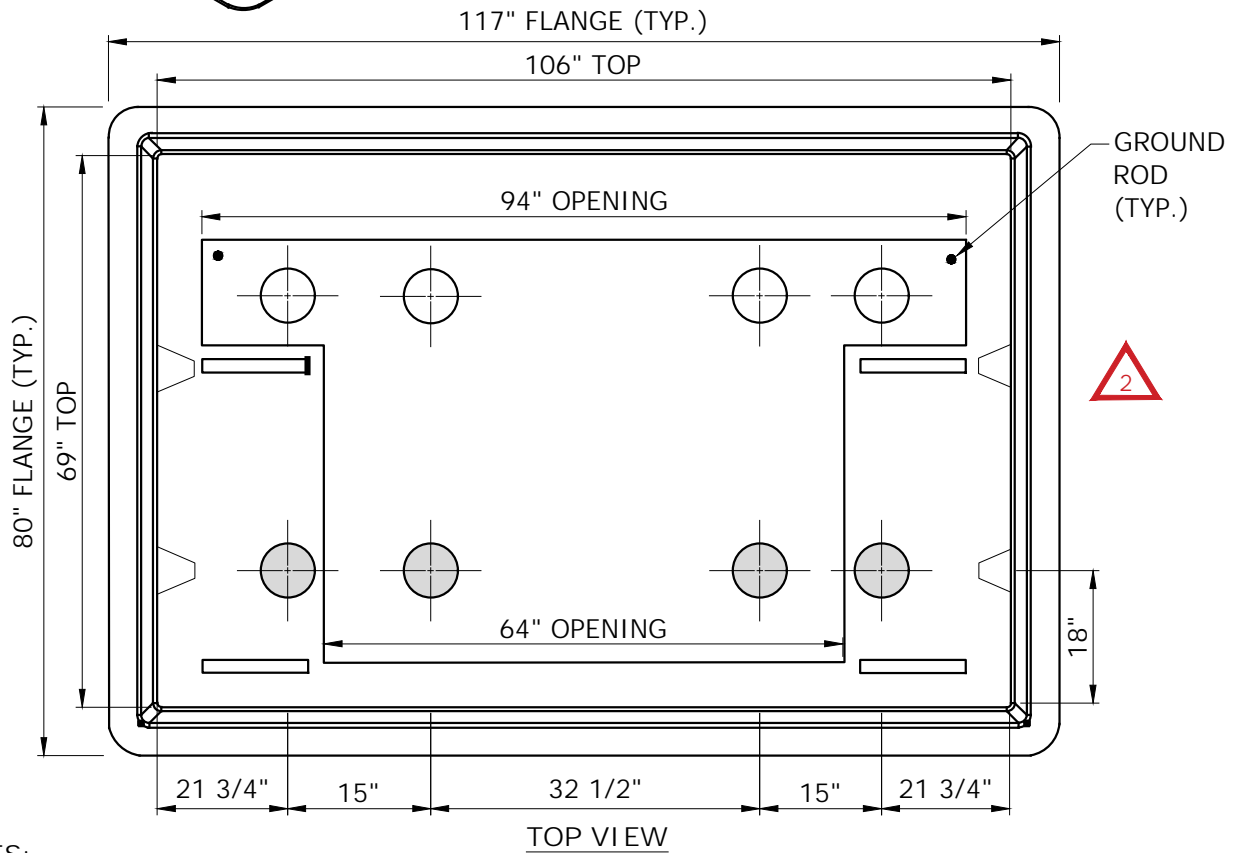

NOTES:

1. SERVICE PROVIDER'S DESIGN SERVICES TO DETERMINE QUANTITY AND PLACEMENT OF CONDUITS.
2. SHADED DUCT IS PREFERRED LOCATION FOR 48" x 45° SWEEPS.
3. RIGHT SIDE POSITIONS ARE DESIGNATED FOR FAULT INTERRUPTION.
4. BOX PAD FITS THE FOLLOWING SWITCHGEAR ENCLOSURE SIZES: 61" x 102" AND 65" x 102.
5. MINIMUM SUBGRADE EXCAVATION DIMENSION IS 32 INCHES.
6. CONTRACTOR IS TO SCHEDULE A CONDUIT PLACEMENT MEETING WITH DESIGN SERVICES PRIOR TO INSTALLATION.

		INITIATED BY	MRH	REVISION NO.	2	SR-242 Pg. 4 of 4
		ESR COMM.	7-12	ESR COMM.	2-24	
				EFFECTIVE DATE	2-24	

USE: Multi-story, zero lot line building

EQUIPMENT AT GRADE IN OPEN-AIR BUILDING ALCOVE





PURPOSE:

To provide the customer with initial information for alcove design when there are no other options for installation of Company equipment due to building on the lot line. Consultation with Company Design Services is required prior to plan finalization.

NOTES:

1. Area shall be maintained as an open air environment in front of equipment. A chain link style gate, without slats that would limit air circulation, can be installed as a means of restricting access to the area. Gates shall be made to swing open to a minimum of 180 degrees or be capable of being rolled clear of the entire alcove opening in front of Company equipment. A roll-up style door in front of the equipment is not acceptable.
2. All walls surrounding equipment, top, sides and floors shall be three hour fire rated, and shall be of concrete or masonry construction. Exterior wall adjacent to and extending ten feet from perimeter of the opening shall have a three hour fire resistance rating and be of concrete or masonry construction.
3. A minimum of 25 foot wide driveable area shall be maintained in front of the alcove to allow for crane set-up for installation and maintenance of Company equipment.
4. A minimum of 30 feet vertical clearance from finished grade to lowest point of structure is required.
5. A minimum alcove dimension of 42 feet wide by 15 feet deep is required to allow for proper clearance of equipment from the building and to assist with installation and maintenance. Verify alcove dimensions with Design Services in order to accommodate all Company equipment within this space, additional area may be required.
6. A ten foot minimum work area is required in front of Company equipment. Work areas allowed for operating personnel are alleys, sidewalks or parking areas with a minimum depth or width of ten feet that can be restricted. Driveways or streets are not considered acceptable work areas.
7. Equipment location and clearances shall be determined by Design Services and provided on the approved Construction Drawing. Minimum clearances provided on this standard must be maintained.
8. Any Public Utility equipment that will be installed within this alcove shall not be taller than 3 feet and the required 3 foot of separation from Company equipment must be maintained. Coordinate with Design Services before placing any non-Company owned equipment within this space and verify that easements allow for this placement.
9. Refer to SR-108 for easement requirements.

 Tucson Electric Power	 UniSourceEnergy SERVICES SANTA CRUZ COUNTY	INITIATED BY	JAB	REVISION NO.	0	SR-243 Pg. 1 of 2
		ESR COMM.	7-23	ESR COMM.	-	
				EFFECTIVE DATE	7-23	

USE: MULTI-STORY,
ZERO LOT LINE
BUILDING

EQUIPMENT AT GRADE IN
OPEN-AIR BUILDING ALCOVE

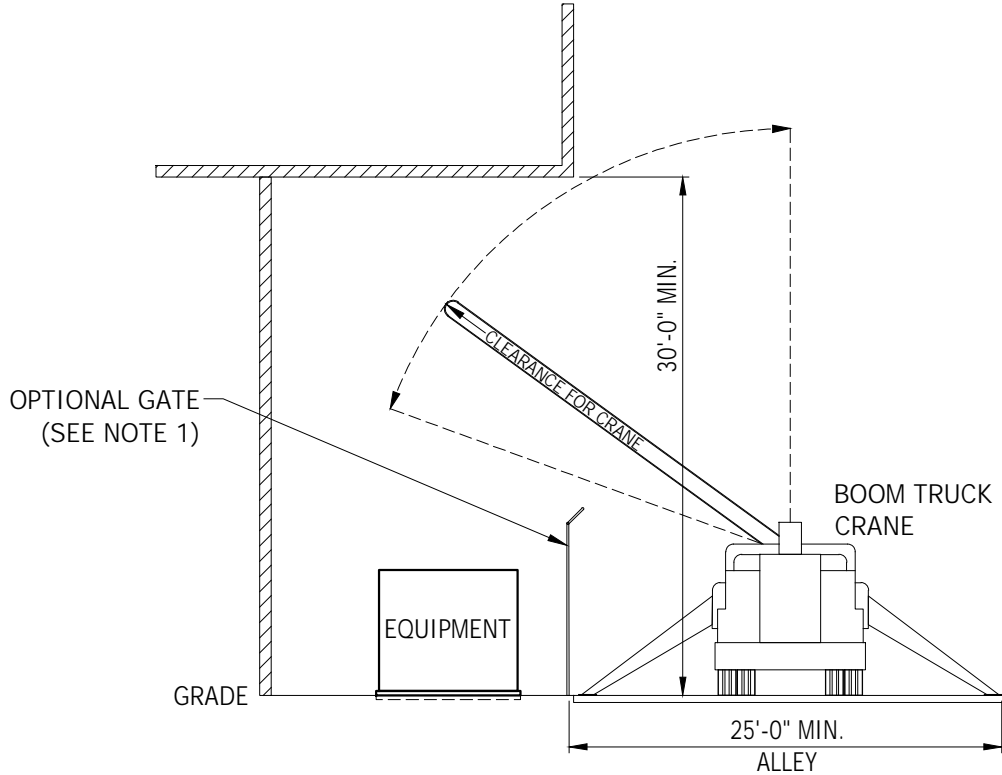

ALCOVE ELEVATION VIEW

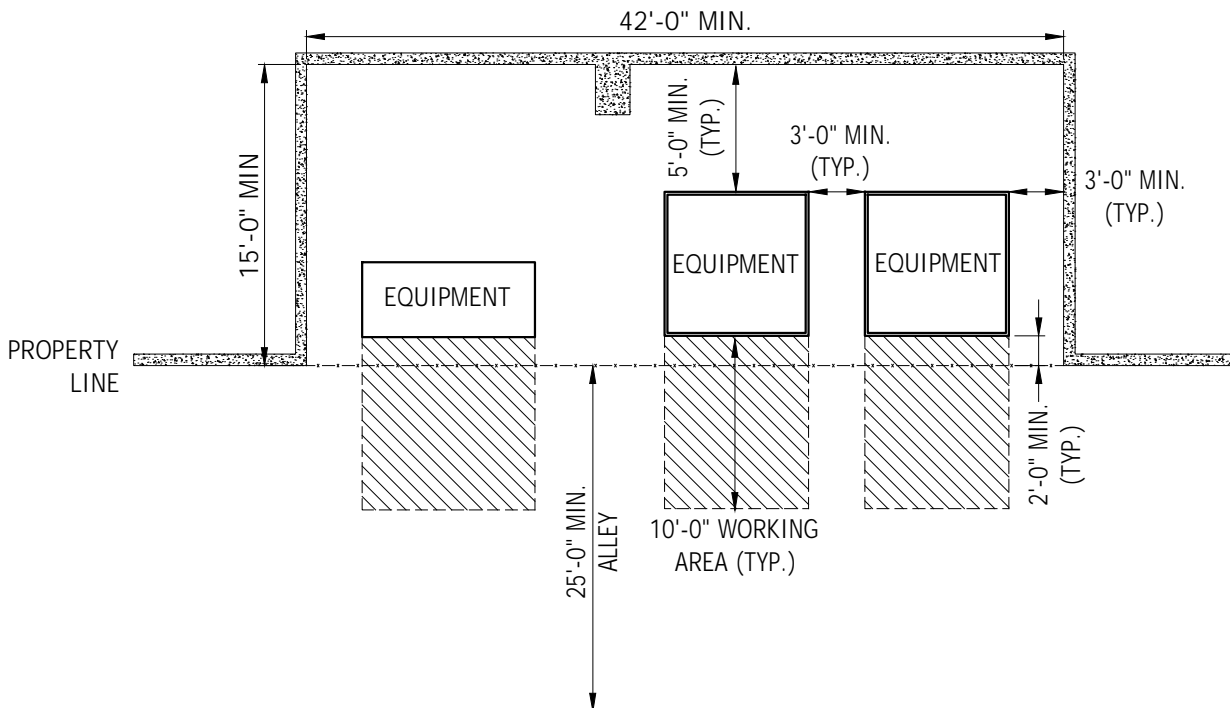

ALCOVE PLAN VIEW

		INITIATED BY	JAB	REVISION NO.	0	SR-243
		ESR COMM.	7-23	ESR COMM.	-	
				EFFECTIVE DATE	7-23	Pg. 2 of 2

300 SECTION SERVICE

<u>TITLE</u>	<u>SR-No.</u>
<u>Entrance Facilities</u>	
Load Balancing	
Typical Service Entrance	
Socket Wiring	
<u>Electric Service Lines</u>	
Overhead Service Lines	
Underground Service Lines	
Service Trenches	301
Overhead or Underground Service and Meter Location	304
Service Entrance with Conduit Riser Overhead	305
Service Entrance on a Pole	307
Three-Phase Underground Service from Overhead, 600A or Less	308
Single-Phase Underground Service from Overhead, 400A	308A
Three-Phase Underground Service from Pad-Mounted Transformer, 600A	309
Service Entrance Underground	310
Trenching, Service Single-Phase	312
Service Entrance Temporary, Underground	314

ENTRANCE FACILITIES



LOAD BALANCING

Contractors and other installing electrical work are to balance the load on three-wire and four-wire systems. This is advantageous to the customer and to Service Provider because it will give the customer better voltage regulation and maximum use of service entrance equipment.

TYPICAL SERVICE ENTRANCES

Typical service entrances for residences shall be installed in accordance with Company Standards SR-305, SR-310, SR-405, & SR-408. Service termination requirements for underground service to multiple metered installations are depicted on SR-425 and SR-426. Service entrance size for both residential and commercial installations is defined to be the nameplate ampere rating of the associated panelboard or switchboard. The Service Provider will determine the conduit and service conductor size based on the nameplate rating on single-phase installations. For three-phase installations, TEP maximum for conduit is four (4) inches and service conductor is 600kcmil. Conduit and wire size for three-phase installations in UES Santa Cruz shall be approved by Design Services.

SOCKET WIRING

Meter socket will be wired in accordance with Company Standards, series SR-400.

ELECTRIC SERVICE LINES

OVERHEAD SERVICE LINES

Service Provider will install (1) one span of overhead service line to the customer's approved point of attachment from the last pole on the overhead distribution system.

UNDERGROUND SERVICE LINES

Service Provider normally will install an underground service line to a residence in a customer-provided conduit system. For residences exceeding 300 amp service rating, commercial, and other installations, the customer should contact Service Provider to determine the point of delivery and the resultant responsibilities for installation.



SERVICE TRENCHES

Trenching and conduit system for service will be in accordance with Company trenching and meter location standards SR-312 and SR-405. The location and routing of the service trench made necessary by noncompliance with these requirements will be made by the customer at his expense.

OVERHEAD AND UNDERGROUND SERVICE LINES



For line extensions, when a customer is requesting or required to be served from an existing underground line, the extension must remain underground from the beginning to the end of the installation. If an overhead line extension is requested the extension must remain overhead from the beginning to the end of the installation. A combination of overhead and underground line extension is not allowed. Note: Local Governing Codes may prohibit overhead line extensions, in specific areas.

 Tucson Electric Power		INITIATED BY	GC	REVISION NO.	6	SR-301 Pg. 1 of 1
		ESR COMM.	8-06	ESR COMM.	11-21	
				EFFECTIVE DATE	11-21	

USE: RESIDENTIAL SINGLE DWELLING ELECTRIC METER LOCATIONS WHERE POWER LINE IS ALONG THE ALLEY OR REAR PROPERTY LINE.

OH OR UG SERVICE AND METER LOCATION



REAR PROPERTY LINE UTILITY PLACEMENT

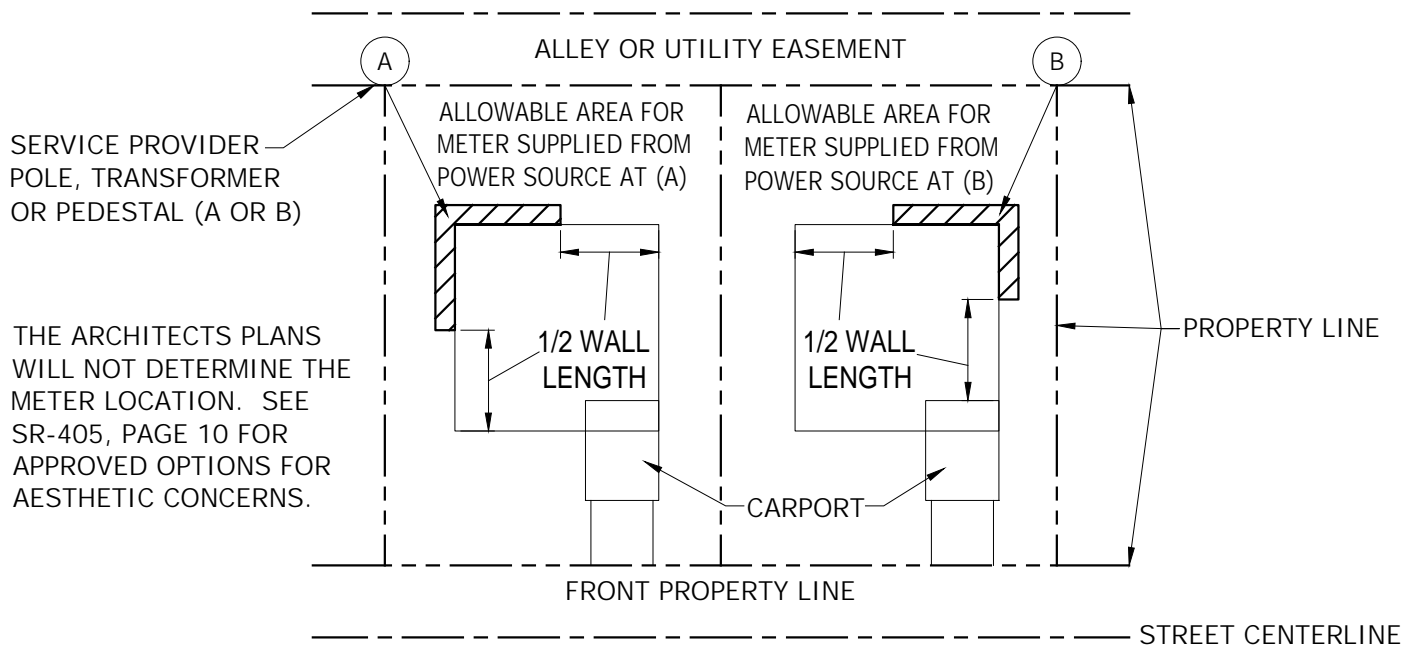

NOTES:

1. REAR PROPERTY LINE UTILITY PLACEMENT REQUIRES THE METER TO BE LOCATED WITHIN ONE-HALF (1/2) THE LENGTH OF THE REAR OR SIDE WALL NEAREST THE DESIGNATED POWER SOURCE (CLOSEST QUADRANT).
2. THE LOT CORNER FROM WHICH THE METER IS TO BE SERVED SHALL BE DESIGNATED BY DESIGN SERVICES.
3. ALL RESIDENTIAL NEW METERS SHALL BE LOCATED ON AN EXTERIOR WALL, BUT NOT UNDER A CARPORT, BREEZEWAY, PATIO, PORCH, OR AREA THAT CAN BE ENCLOSED WITH BUILDING EXPANSION. EXISTING OVERHEAD TYPE SERVICE ENTRANCES MAY REMAIN UNDER A CARPORT, BREEZEWAY, PATIO, OR PORCH UNLESS THE AREA IS TO BE ENCLOSED. UNDERGROUND TYPE SERVICE ENTRANCES MUST BE RELOCATED IF THE SERVICE IS UPGRADED. ALL RESIDENTIAL SERVICE TYPES MUST BE RELOCATED IF THE SERVICE ENTRANCE IS ENCLOSED WITHIN ANY ROOM, GARAGE, SCREENED IN AREA, ETC. SEE SR-405, FOR CUSTOMER RESPONSIBILITY RELATED TO SERVICE REPLACEMENT, UPGRADE OR RELOCATION.
4. THE METER SHALL BE ACCESSIBLE FOR READING, CONNECTING, DISCONNECTING, TESTING AND MAINTENANCE WITHOUT REQUIRING PASSAGE THROUGH RESTRICTED PRIVATE AREAS, LOCKED GATES OR FENCES. SERVICE PROVIDER RESERVES THE RIGHT TO DETERMINE FINAL METER LOCATION.
5. IN TOWNHOUSE DEVELOPMENTS WHERE SIDE WALL LOCATIONS ARE NOT AVAILABLE, METER MAY BE LOCATED ANYWHERE ON REAR WALL.
6. SEE SR-305 FOR OVERHEAD SERVICE ENTRANCE INSTALLATION DETAILS.
7. SEE SR-310 FOR UNDERGROUND SERVICE ENTRANCE DETAIL AND SR-312 FOR TRENCHING DETAIL.
8. FOR POWER LINE ALONG THE STREET, REFER TO SR-304 PAGE 2.
9. FOR ADDITIONAL INFORMATION IN REGARDS TO METER LOCATIONS, CALL DESIGN SERVICES.
9. SECONDARY OR SERVICE WIRES THAT CROSS A ROAD, ALLEY OR RIGHT-OF-WAY MAY REQUIRE THE INSTALLATION OF A LIFT POLE. REFER TO TABLE 1 AND DESIGN SERVICES FOR ADDITIONAL INFORMATION AND SITE SPECIFIC REQUIREMENTS.



 Tucson Electric Power	 SANTA CRUZ COUNTY	INITIATED BY	GC	REVISION NO.	3	SR-304 Pg. 1 of 3
		ESR COMM.	2-06	ESR COMM.	4-23	

USE: RESIDENTIAL SINGLE DWELLING ELECTRIC METER LOCATIONS WHERE POWER LINE IS ALONG THE STREET OR FRONT PROPERTY LINE.

OH OR UG SERVICE AND METER LOCATION



FRONT PROPERTY LINE UTILITY PLACEMENT

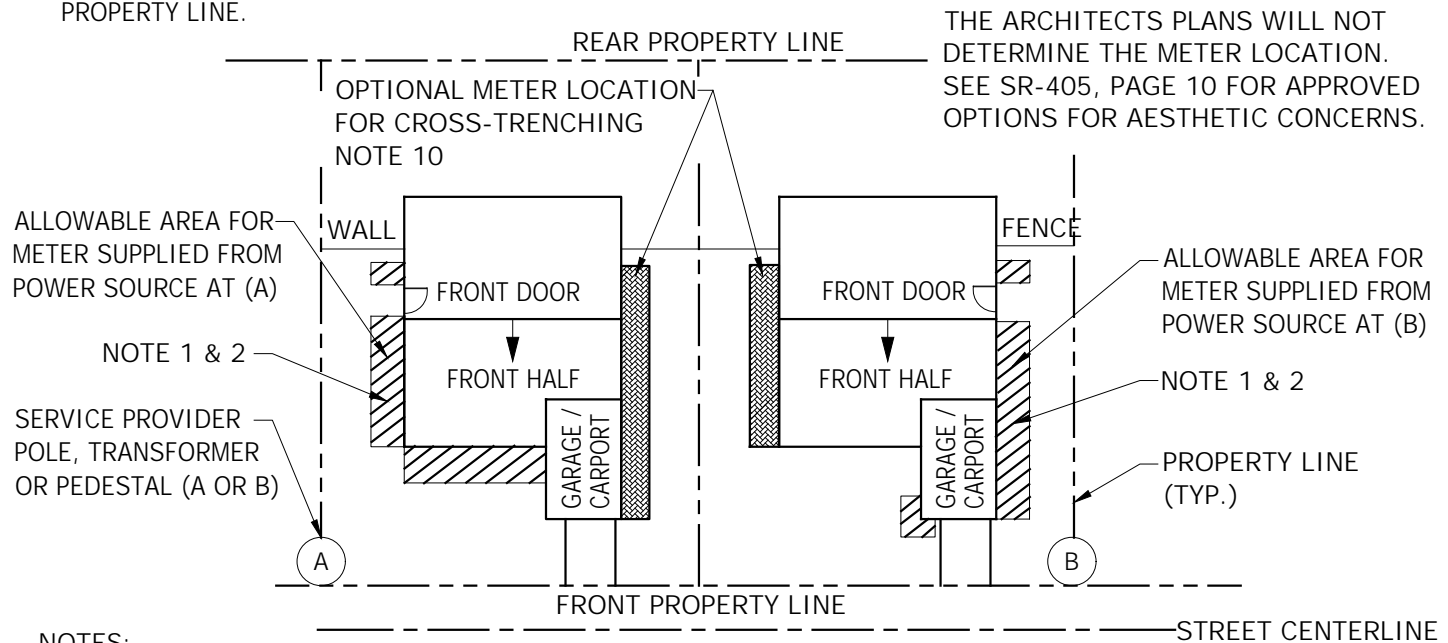

THE ARCHITECTS PLANS WILL NOT DETERMINE THE METER LOCATION. SEE SR-405, PAGE 10 FOR APPROVED OPTIONS FOR AESTHETIC CONCERNS.

NOTES:

1. FRONT PROPERTY LINE UTILITY PLACEMENT REQUIRES THE METER TO BE LOCATED WITHIN ONE-HALF (1/2) THE LENGTH OF THE REAR OR SIDE WALL NEAREST THE DESIGNATED POWER SOURCE (CLOSEST QUADRANT) ON OVERHEAD SERVICE INSTALLATIONS.
2. THE LOT CORNER FROM WHICH THE METER IS TO BE SERVED SHALL BE DESIGNATED BY DESIGN SERVICES, AND FOR SUBDIVISIONS, WILL BE DEPICTED ON SERVICE PROVIDER'S CONSTRUCTION DRAWING OF THE UNDERGROUND ELECTRICAL DISTRIBUTION SYSTEM.
3. ALL RESIDENTIAL NEW METERS SHALL BE LOCATED ON AN EXTERIOR WALL, BUT NOT UNDER A CARPORT, BREEZEWAY, PATIO, PORCH, OR AREA THAT CAN BE ENCLOSED WITH BUILDING EXPANSION. EXISTING OVERHEAD TYPE SERVICE ENTRANCES MAY REMAIN UNDER A CARPORT, BREEZEWAY, PATIO, OR PORCH UNLESS THE AREA IS TO BE ENCLOSED. UNDERGROUND TYPE SERVICE ENTRANCES MUST BE RELOCATED IF THE SERVICE IS UPGRADED. ALL RESIDENTIAL SERVICE TYPES MUST BE RELOCATED IF THE SERVICE ENTRANCE IS ENCLOSED WITHIN ANY ROOM, GARAGE, SCREENED IN AREA, ETC. SEE SR-405, FOR CUSTOMER RESPONSIBILITY RELATED TO SERVICE REPLACEMENT, UPGRADE OR RELOCATION.
4. THE METER SHALL BE ACCESSIBLE FOR READING, CONNECTING, DISCONNECTING, TESTING AND MAINTENANCE WITHOUT REQUIRING PASSAGE THROUGH RESTRICTED PRIVATE AREAS, LOCKED GATES OR FENCES. SERVICE PROVIDER RESERVES THE RIGHT TO DETERMINE FINAL METER LOCATION.
5. SEE SR-305 FOR OVERHEAD SERVICE ENTRANCE INSTALLATION DETAILS.
6. SEE SR-310 FOR UNDERGROUND SERVICE ENTRANCE DETAIL AND SR-312 FOR TRENCHING DETAIL.
7. FOR POWER LINE ALONG ALLEY OR REAR PROPERTY LINE, REFER TO SR-304 PAGE 1.
8. FOR ADDITIONAL INFORMATION IN REGARDS TO METER LOCATION CONTACT DESIGN SERVICES.
9. SECONDARY OR SERVICE WIRES THAT CROSS A ROAD, ALLEY OR RIGHT-OF-WAY MAY REQUIRE THE INSTALLATION OF A LIFT POLE. REFER TO TABLE 1 AND DESIGN SERVICES FOR ADDITIONAL INFORMATION AND SITE SPECIFIC REQUIREMENTS.
10. THE UNDERGROUND SERVICE LENGTH, IF CROSS-TRENCHING IS TO BE 100 FEET OR LESS. ELECTRICAL GRADE SCHEDULE 40 PVC OR HDPE CONDUIT MUST BE USED AND IT MAY HAVE NO GREATER THAN 360 DEGREES OF BENDS WITH THE CONDUIT RUN. THE METER WILL BE LOCAOTED IN FRONT OF ANY WALL OR FENCE. CONTACT DESIGN SERVICES FOR APPROVAL PRIOR TO PANEL INSTALLATION AND TRENCH EXCAVATION.



 	INITIATED BY	GC	REVISION NO.	6	SR-304 Pg. 2 of 3
	ESR COMM.	2-06	ESR COMM.	4-23	
			EFFECTIVE DATE	4-23	

USE: TO DETERMINE WHEN LIFT
POLE IS REQUIRED.

OH OR UG SERVICE AND METER LOCATION

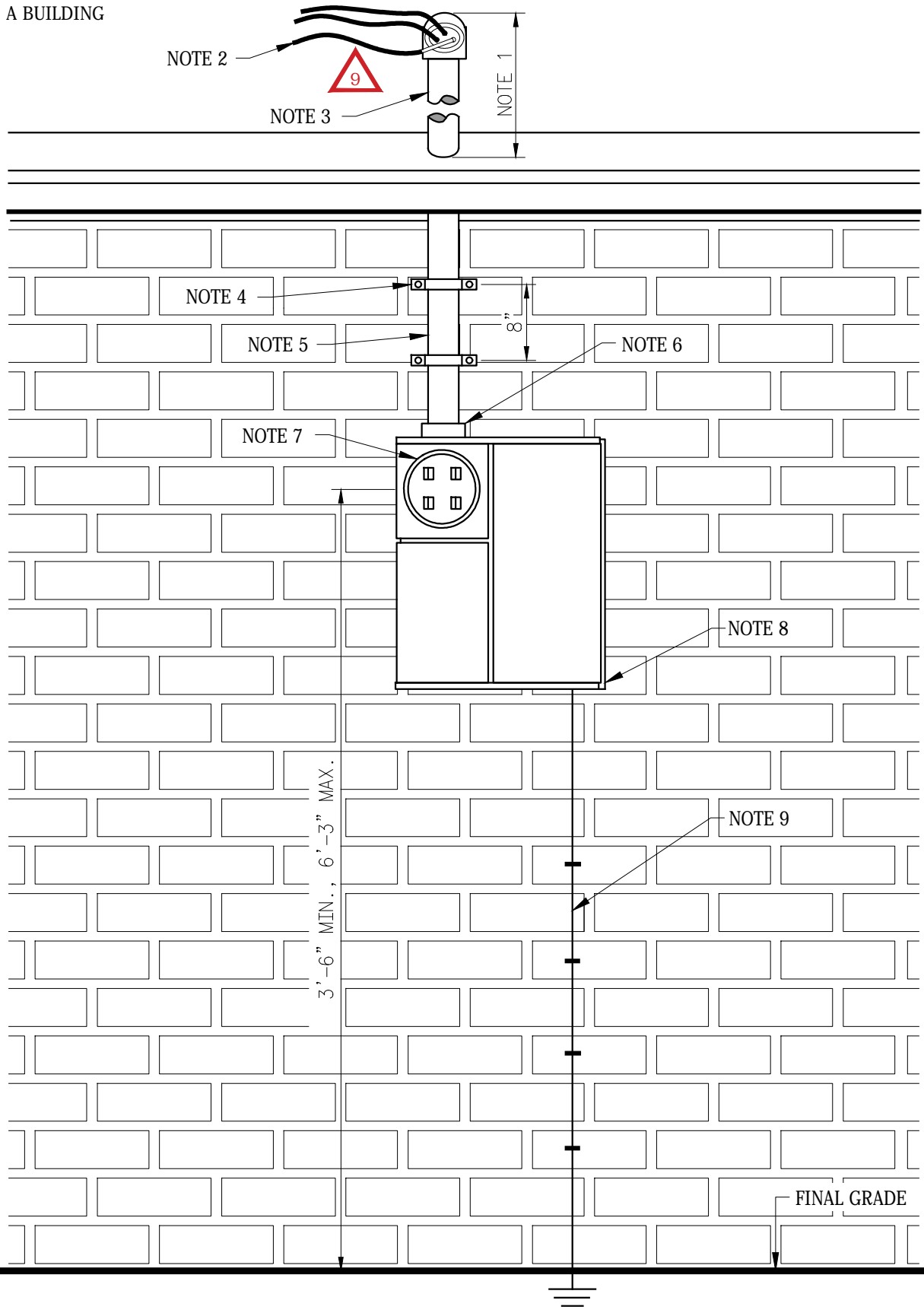

TABLE 1
SECONDARY AND SERVICE LIFT POLE

SERVICE ENTRANCE (IN AMPS)	WIRE SIZE (TYPICAL)	MAXIMUM LENGTH ALLOWED WITHOUT LIFT POLE IF TAPPED FROM POLE (IN FEET)	MAXIMUM LENGTH ALLOWED WITHOUT LIFT POLE IF TAPPED FROM MID-SPAN (IN FEET)
125	#4 TRI	125	80
200	1/0 TRI	100	60
400	4/0 TRI	60	35
600	350 OPEN 3C	45	-

USE: ENTRANCE
REQUIREMENTS
ON A BUILDING

SERVICE ENTRANCE WITH CONDUIT RISER OVERHEAD



USE: PARAPET WALL
INSTALLATION

SERVICE ENTRANCE WITH CONDUIT RISER OVERHEAD

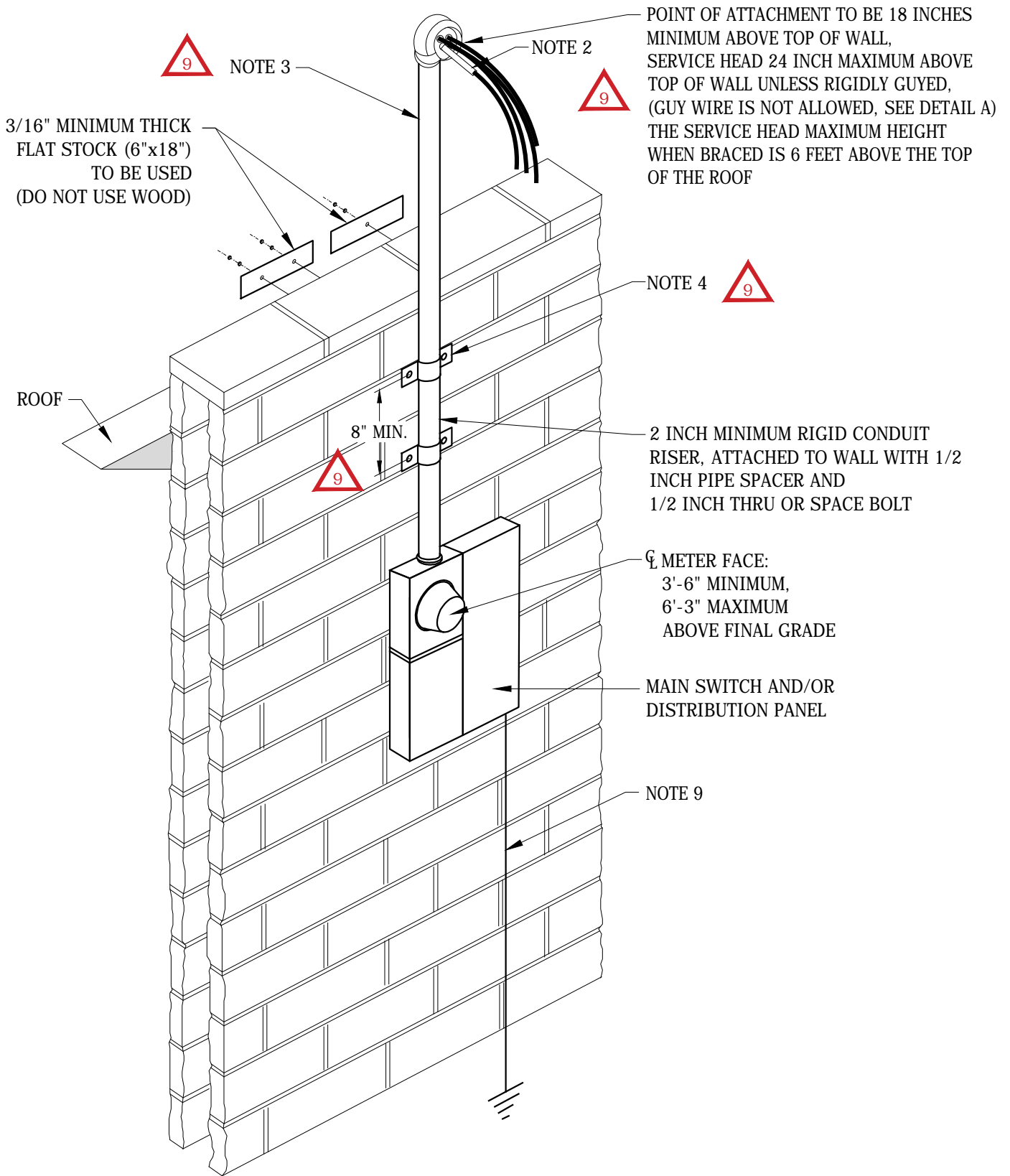

USE: Entrance requirements on a building



SERVICE ENTRANCE WITH CONDUIT RISER OVERHEAD



NOTES:

1. A self-supported rigid conduit riser may extend a maximum of 3 feet above the roof if 2 inch diameter conduit is used or 4 feet above the roof if 2 1/2 inch diameter conduit is used. The top of the weatherhead shall be a minimum of 24 inches above the roof. If additional riser height is needed for service conductor clearance as required by applicable electrical codes, the riser shall be rigidly braced or rigidly guyed (guy wire is NOT allowed) from a point within 8 inches of the weatherhead. The maximum height of the weatherhead from the roof is 7 feet. No conduit coupling shall be installed above the roofline.
2. Entrance conductors shall extend at least 24 inches from the conduit or cable weatherhead. The neutral conductor shall be identified with solid white tape for 120-240V and grey tape for 480V from the weatherhead for six (6) inches. When grouping with multiple risers, the entrance conductors shall extend at least 48 inches to allow for permanent connections. Multiple risers are to be no greater than 26 inches apart from each other.
3. A firm point of attachment for Service Provider service wires shall be provided by the customer; for example, a well-anchored rigid conduit mast, a suitable dead-end clevis and bolt arrangement furnished by Service Provider and installed by the customer in masonry walls, or other attachments as field conditions may warrant. Wood masts are no longer acceptable for new or remodeled points of attachment. See Note 11 for height of the attachment point above final grade.
4. Conduit risers must be clamped solidly to the building for adequate support of the service drop cable. Where rafters extend beyond the wall line, the conduit riser shall be firmly braced and/or blocked between the rafters with 2x4 or 2x6 inch lumber. Where no rafters extend beyond the wall line, the conduit risers must be firmly secured to the masonry wall with a minimum of two 2-hole pipe straps located near the top of the wall and spaced no less than 8 inches apart. Conduit straps shall be attached with 1/4 inch minimum toggle bolts or 1/4 inch minimum lag screws in lag shield anchors. Consult Design Services for means of attachment to adobe walls or other masonry.
5. The smallest diameter conduit for entrance risers which support service drop cable shall be 2 inches. Service riser conduit(s) that do not support the service drop cable shall be a minimum of 2 inches, as in the case when grouping with multiple risers (See Note 2). 2 1/2 inch diameter conduit(s) shall be installed as indicated in Note 1.
6. If utilized, a meter board 10"x22"x3/4" or larger, treated for outdoor application, shall be fastened securely to the building wall for mounting meter sockets, switches, and other devices necessary for adequate metering and protection. Other mounting arrangements are subject to approval by Design Services.
7. Meters and instrument transformers will be furnished by the Service Provider. Meter sockets are to be purchased, installed and maintained by the customer per SR-400 Series.
8. The customer will provide a service disconnecting device which meets all requirements of the current National Electrical Code. The operation of the device shall be such that the neutral (grounded conductor) is not broken when the device is opened. The operating handle or member should be capable of being sealed either open or closed.



		INITIATED BY	SC	REVISION NO.	10	SR-305 Pg. 3 of 5
		ESR COMM.	3-78	ESR COMM.	3-24	
		ESR COMM.	3-78	EFFECTIVE DATE	3-24	

SERVICE ENTRANCE WITH CONDUIT RISER OVERHEAD



NOTES (CONT'D):

9. The service disconnect shall be effectively grounded in compliance with the applicable requirements of local governmental codes, or National Electrical Code requirements in the absence of local codes.
10. Contact the Design Services if building structure is not similar to SR-305, Pages 1 & 2.
11. The point of attachment on the customer's building must be at a sufficient height, to provide the following minimum ground clearances to the Service Provider service drop cable (0-750V).
 - A. Over parking lots, service areas, public streets, alleys or driveways open to the public or areas reasonably expected to be subject to equestrian activity, 18 feet.
 - B. Over private residential driveways and spaces or ways accessible to pedestrians only, 15 feet. May be reduced to 12 feet for supply conductors limited to 300V to ground and located more than 25 feet measured in any direction from a swimming pool or diving platform.
12. If more than one meter socket is installed, the centerline of each meter is to be a minimum of 3'-6" above final grade. Maximum meter height above grade, as measured from meter centerline, is 6'-3".



16. A new service entrance shall be installed to provide a minimum of 3 feet clearance to gas meter regulator or regulator extension vent. For clearance guidance when electric service entrance is being relocated or upgraded, refer to SR-910.

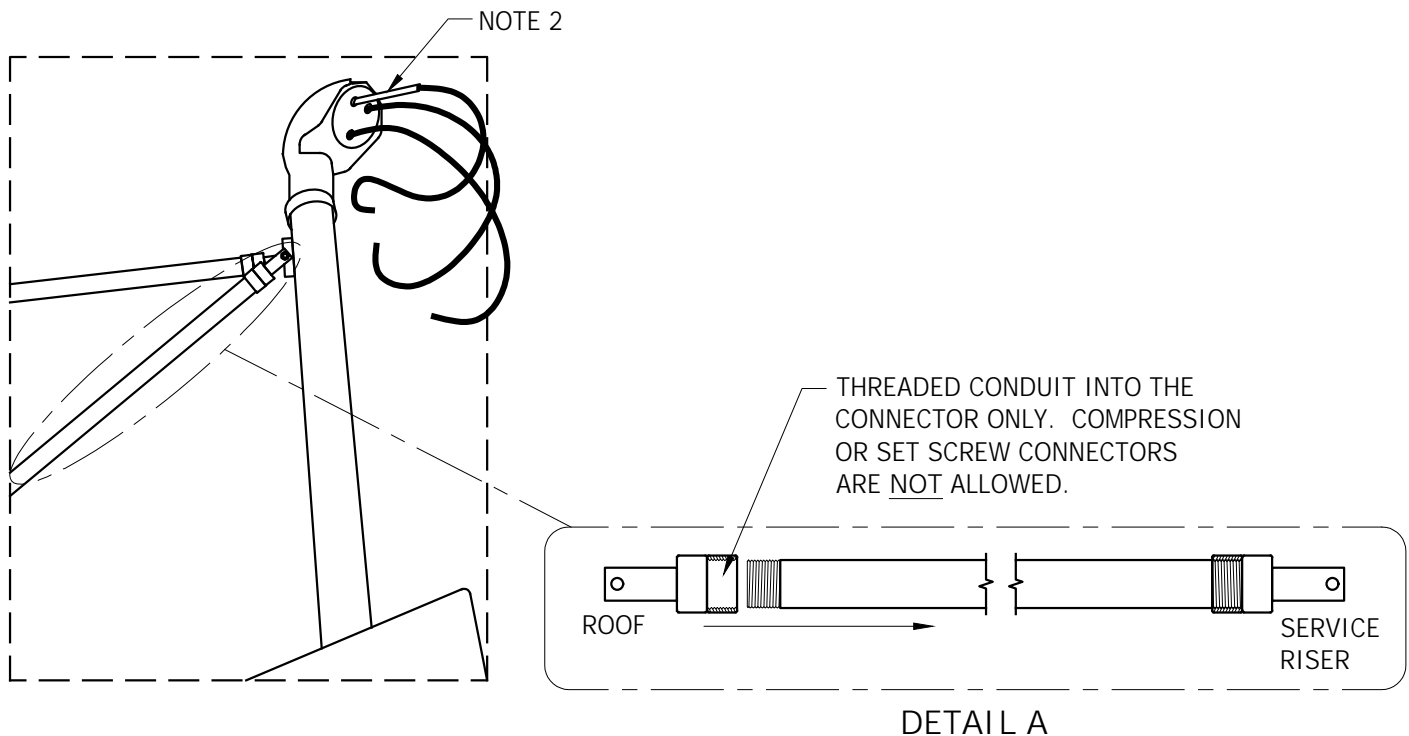

USE: REPLACEMENT OF A
ROOF MOUNTED POINT
OF ATTACHMENT (POA)

SERVICE ATTACHMENT SUPPORT

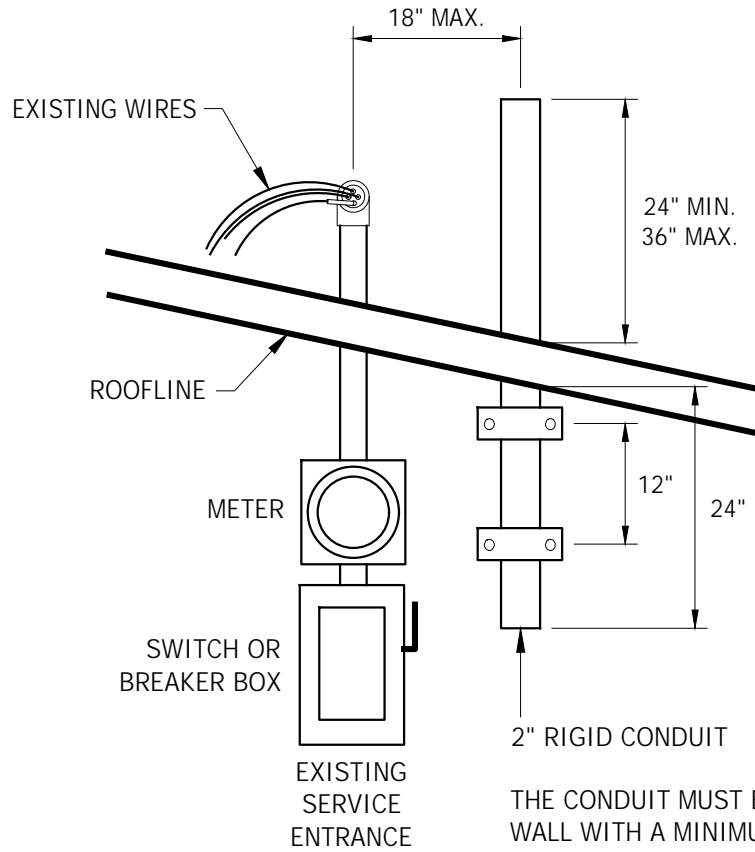

THE CONDUIT MUST BE FIRMLY SECURED TO THE WALL WITH A MINIMUM OF TWO 2-HOLE PIPE STRAPS ATTACHED WITH 1/4 INCH MINIMUM TOGGLE BOLTS OR 1/4 INCH MINIMUM LAG SCREWS IN LAG SHIELD ANCHORS

NOTES:

1. POA TO BE LOCATED NOT MORE THAN 18 INCHES FROM ELECTRIC SERVICE RISER.
- 14 2. WHEN MULTIPLE RISERS ARE NEEDED, THEY ARE TO BE NO GREATER THAN 26 INCHES APART FROM EACH OTHER.
3. WHEN WORK IS COMPLETED, CALL DESIGN SERVICES FOR INSPECTION.
4. IF YOU NEED TO DEVIATE FROM THIS PREFERRED SERVICE INSTALLATION, PLEASE CONSULT WITH DESIGN SERVICES BEFORE INSTALLATION.
5. TEP - AN INSULATED WIRE HOLDER FOR ATTACHMENT OF SERVICE WIRE TO CONDUIT WILL BE PROVIDED.
6. UES SANTA CRUZ - CUSTOMER TO PROVIDE AN INSULATED WIRE HOLDER FOR ATTACHMENT OF SERVICE WIRE TO CONDUIT.



SERVICE ENTRANCE ON A POLE

REFER TO SR-452 FOR THE COMPLETE APPROVED METERING AND SERVICE EQUIPMENT LIST

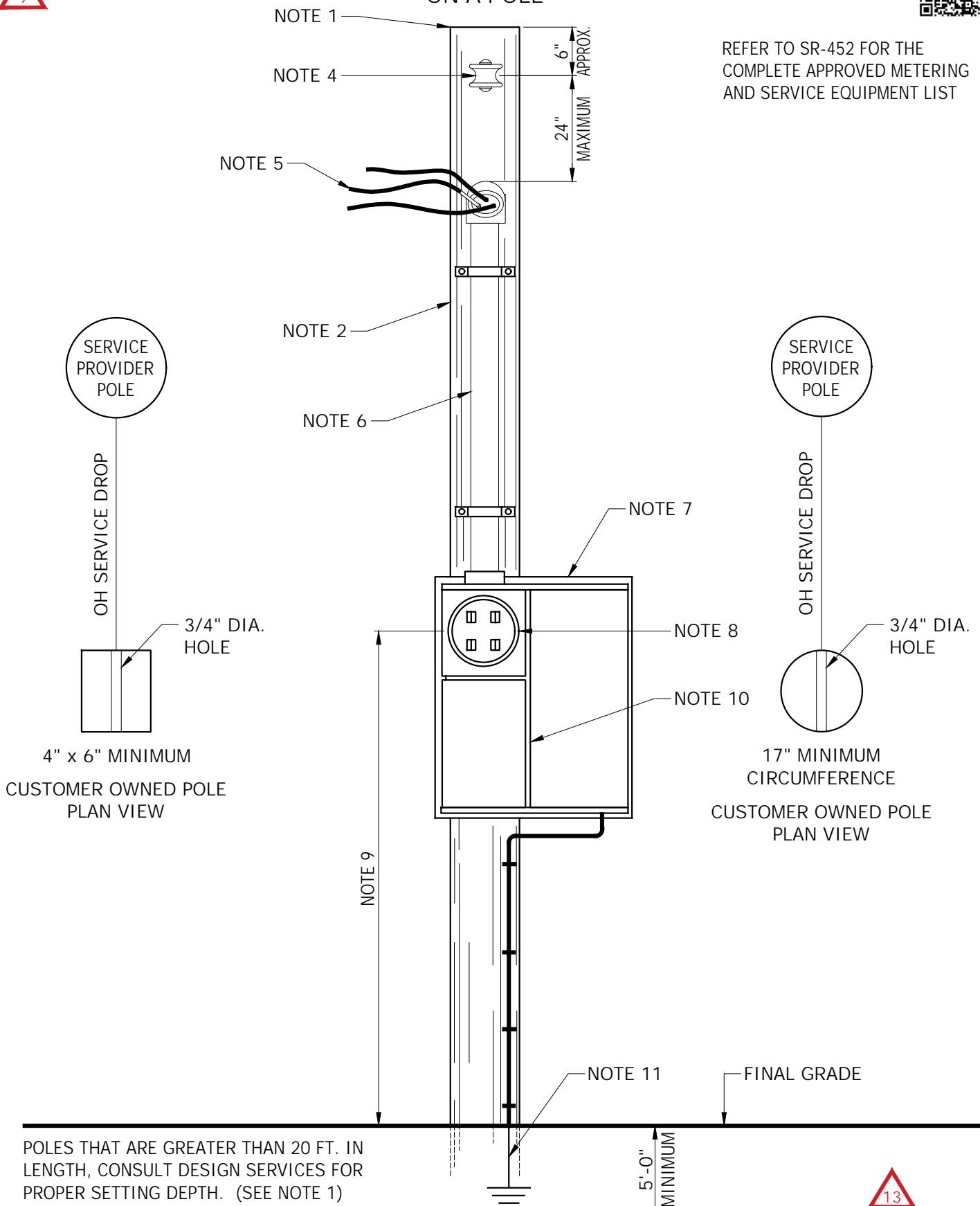

POLES THAT ARE GREATER THAN 20 FT. IN LENGTH, CONSULT DESIGN SERVICES FOR PROPER SETTING DEPTH. (SEE NOTE 1)





SERVICE ENTRANCE ON A POLE



NOTES:

1. The service pole shall be a treated Class 6 wood pole with a minimum circumference of 17 inches at the top or a 4 x 6 inch (minimum) rectangular pole. Length to be determined by Design Services.  Setting depth to be a minimum of at least 5 feet. A pole to be used for permanent service shall be treated to resist rot and weathering. The pole shall be tall enough to give the service drop wires proper clearance above final grade as specified in Note 3. For poles extending more than 15 feet above ground, consult Design Services for pole specifications and setting depths. Holderness Supplies, 450 E Irvington Road, 520-889-1300 is a known source for purchase of required wood pole.
2. The service pole location will be determined by mutual agreement between the customer and Design Services.
3. The point of attachment to the customer's service pole must be sufficiently high to provide the following minimum ground clearances to the Company's Service drop cable. (0-750V)
 - A. Over parking lots, service areas, public streets, alleys or driveways open to the public, or areas reasonably expected to be subject to equestrian activity - 18 feet.
 - B. Over private residential driveways and spaces or ways accessible to pedestrians only - 15 feet. May be reduced to 12 feet for supply conductors limited to 300V to ground and located more than 25 feet measured in any direction from a swimming pool or diving platform.
4. The conduit or cable weatherhead shall be a minimum of 1 foot below the top of the pole. Weatherhead is to face in the same direction of Service Provider pole to be served from.
 - A. TEP will furnish and install the deadend clevis.
 - B. For UES, the customer will provide and install the deadend clevis.
5. Entrance conductors shall extend at least 24 inches from the conduit or cable weatherhead. The neutral conductor shall be identified with solid white tape for 120-240V and grey tape for 480V from the weatherhead for 6 inches. When grouping with multiple risers, the entrance conductors shall extend at least 48 inches to allow for permanent connections.
6. The smallest diameter conduit for entrance risers shall be 2 inches.
7. A meter board 10" x 22" x 3/4", or larger, treated for outdoor application, shall be fastened securely to the pole for mounting meter sockets, switches, and any other devices necessary for adequate metering and protection.
8. Meters and instrument transformers will be supplied by Service Provider. Meter sockets are to be purchased, installed and maintained by the customer per SR-400 Series.
9. All meter sockets shall be mounted between 3'-6" minimum and 6'-3" maximum from final grade to the center of the meter.
10. The customer will provide a service disconnecting device which meets all requirements of the current National Electric Code. The operation of the device shall be such that the neutral (grounded conductor) is not broken when the device is opened. The operating handle or member shall be capable of being sealed either open or closed.
11. The service disconnect shall be effectively grounded in compliance with the applicable requirements of local governmental codes, or National Electrical Code requirements in the absence of local codes.
12. Temporary service duration is two (2) years or less.

 Tucson Electric Power		INITIATED BY	SC	REVISION NO.	10	SR-307 Pg. 2 of 2
		ESR COMM.	3-78	ESR COMM.	4-23	
				EFFECTIVE DATE	4-23	

THREE-PHASE UNDERGROUND SERVICE FROM OVERHEAD, 600A OR LESS



CUSTOMER RESPONSIBILITIES

1. Provide and install an approved secondary junction box. The box size to be determined by Design Services. The junction box must include a polymer concrete cover with recessed hex head bolts. Align the junction box so that the ducts terminate at the bottom edges of the ends (the faces having the shorter dimension). The top of the box shall be flush with established final grade. (See Material & Approved Manufacturers on this page).
2. Provide and install a duct from the bottom edge of the junction box to the Company pole. Extend the duct up the pole 10 feet above the top of the elbow. The conduit installation shall meet the requirements of SR-205. Concrete encasement is required if a conduit run is more than 150 feet in length, or any length with a combination of 270 degrees (or more) of bends, not to exceed 360 degrees. The vertical sweeps at each end require concrete encasement for a distance of 10 feet from centerline of the conduit run termination.
3. The duct size shall be 4 inches for service entrance ratings of 0-600 Amps. All risers must be secured to pole with standoff brackets (See Material & Approved Manufacturers on this page).
4. Provide and install service cable (maximum of three conductors per phase and a neutral) from the service entrance to the junction box. Cut cables so that they extend to the opposite end of the junction box to provide length required for assembly of connections by Service Provider. Conductors shall not be smaller than 1/0 AWG nor larger than 600kcmil. Secure the lid to the box with the hex head bolts.
5. Identify at the junction box, the neutral conductor(s) (and power leg conductor(s) if service voltage is 240/120V delta), in accordance with National Electrical Code requirements.
6. Identify all conductors with phase tape to insure proper connection. Each neutral conductor from a service lateral is to be identified with an aluminum embossed permanent address tag at the box, 12 inches above the conduits.
7. Rigid Steel, IMC, and Rigid Aluminum conduit must have a protective tape applied. The tape is to be installed starting at 6 inches above final grade down beyond the (HDPE or PVC) coupling joint. Use 10 mil. protection tape in a half lap installation.
8. Refer to SR-108 for Right-of-way and Easement requirements.

MATERIAL & APPROVED MANUFACTURERS

FIGURE 1 - 17" x 30" Junction Box (20k Rated)

TEP Stores Number 7-07-5120
 Armorcast Products Co., Cat. No. A6001640TAX18
 Channell, Cat. No. BULKU1730180062002
 New Basis, Cat. No. FCA173018H-00042
 New Basis, Cat. No. FCA173018T-00006
 New Basis, Cat. No. PCA173018-00042
 Oldcastle, Cat. No. 17301471
 Quazite, Cat. No. A12173018A017

FIGURE 2 - 30" x 48" Junction Box (20k Rated)

TEP Stores Number 7-07-5121
 Channell, Cat. No. BULKU3048180082002
 New Basis, Cat. No. FCA304818T-00042
 New Basis, Cat. No. FCA304818T-01002

Supplier for Approved Material:
 Border States Electric

4" STAND-OFF BRACKET - Aluma-Form, Inc., Cat. No. 4-CSO-7-STK-4-4WT, Lag Screw, 1/2" x 4"

SERVICE PROVIDER RESPONSIBILITIES

- 15

 9. Specify location for junction box and on which quadrant pole riser is to be attached. Location of the junction box will normally be 7 to 12 feet from pole. Junction box should be in a non-traffic area and not within a concrete slab, sidewalk, driveway or driveway path. If located in a traffic area, protective posts must be installed per SR-230.
 10. Provide and install continuation of duct on Company pole and ground the metal riser.
 11. Provide and install cable in the duct from transformer to junction box.
 12. Provide and install connectors at junction box. The load terminals of these connectors shall be the point of delivery for this installation.
 13. Maintain the junction box after the service is connected to the Company distribution system.

 Tucson Electric Power	 UniSource Energy SERVICES SANTA CRUZ COUNTY	INITIATED BY	SC	REVISION NO.	15	SR-308 Pg. 1 of 3
		ESR COMM.	8-81	ESR COMM.	4-23	
				EFFECTIVE DATE	4-23	

USE: THREE-PHASE, 4-WIRE
 SERVICE 208Y/120V,
 240/120V DELTA, OR
 480Y/277V, 600A OR LESS

THREE-PHASE UNDERGROUND SERVICE FROM OVERHEAD, 600A OR LESS

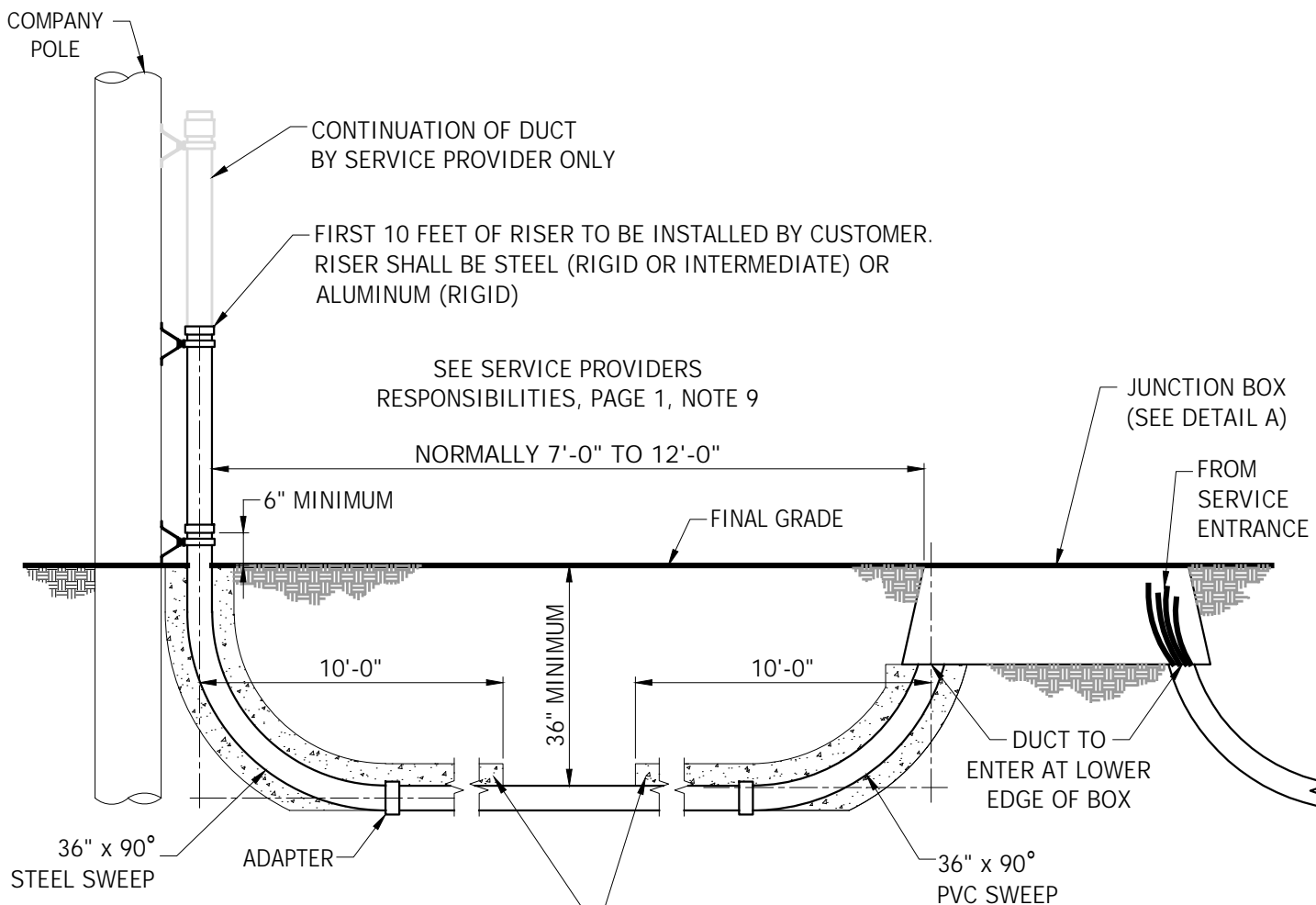

3 INCH MINIMUM/5 INCH MAXIMUM CONCRETE ENCASEMENT, FOR ALL DUCT SIZES (SEE SR-205). CONCRETE ENCASEMENT IS REQUIRED IF A CONDUIT RUN IS MORE THAN 150 FEET IN LENGTH, OR ANY LENGTH WITH A COMBINATION OF 270° (OR MORE) OF BENDS, NOT TO EXCEED 360°.

THESE REQUIREMENTS APPLY TO COMMERCIAL AND INDUSTRIAL CUSTOMERS SERVED UNDERGROUND FROM AN OVERHEAD SYSTEM WITH THREE-PHASE SERVICE ENTRANCE EQUIPMENT RATED 600A OR LESS AND 480V OR LESS.



USE: THREE-PHASE, 4-WIRE
SERVICE 208Y/120V,
240/120V DELTA, OR
480Y/277V, 600A OR LESS

THREE-PHASE UNDERGROUND SERVICE FROM OVERHEAD, 600A



TWO (2)-3/8"
HEX HEAD BOLTS
(TYP.)

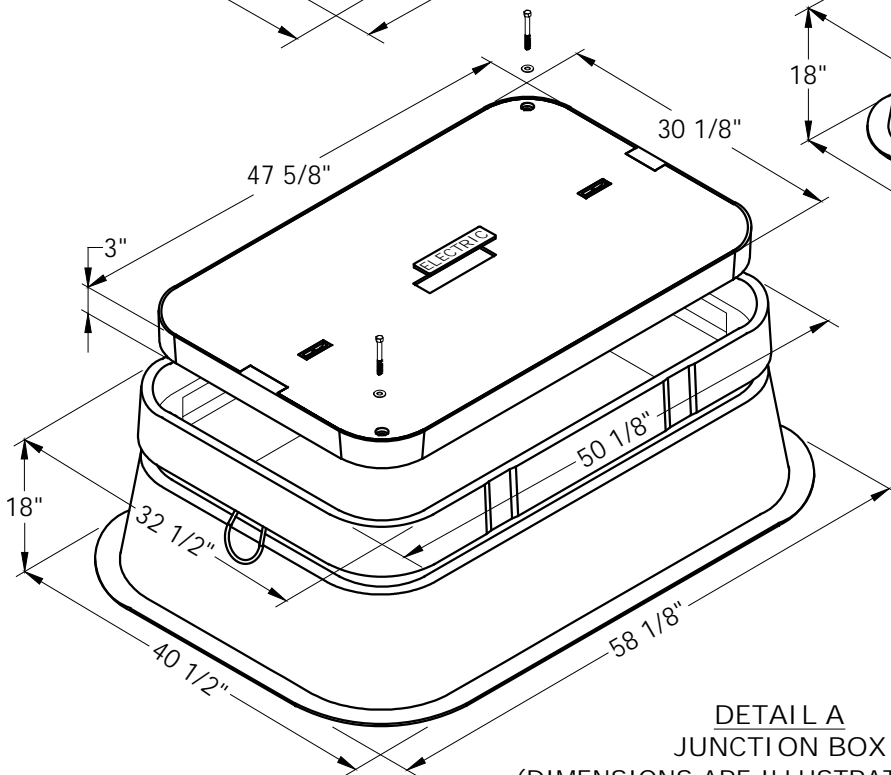
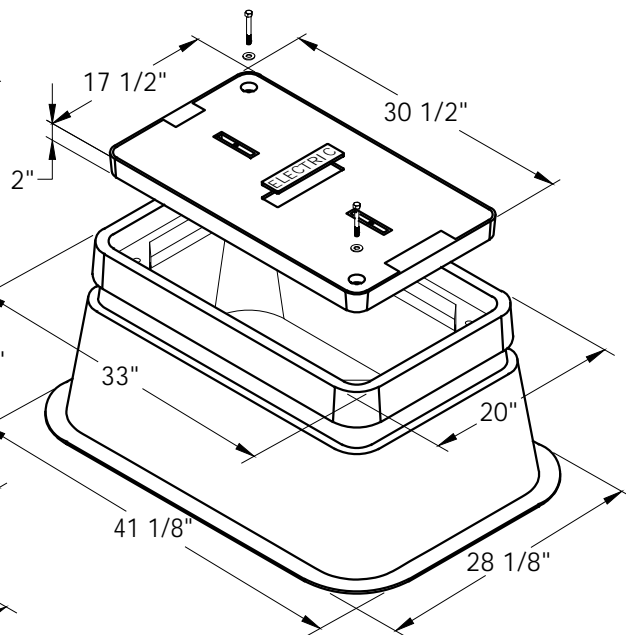
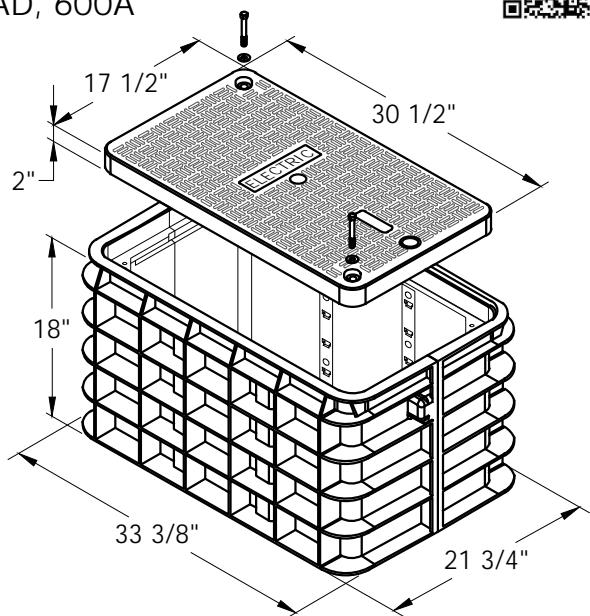
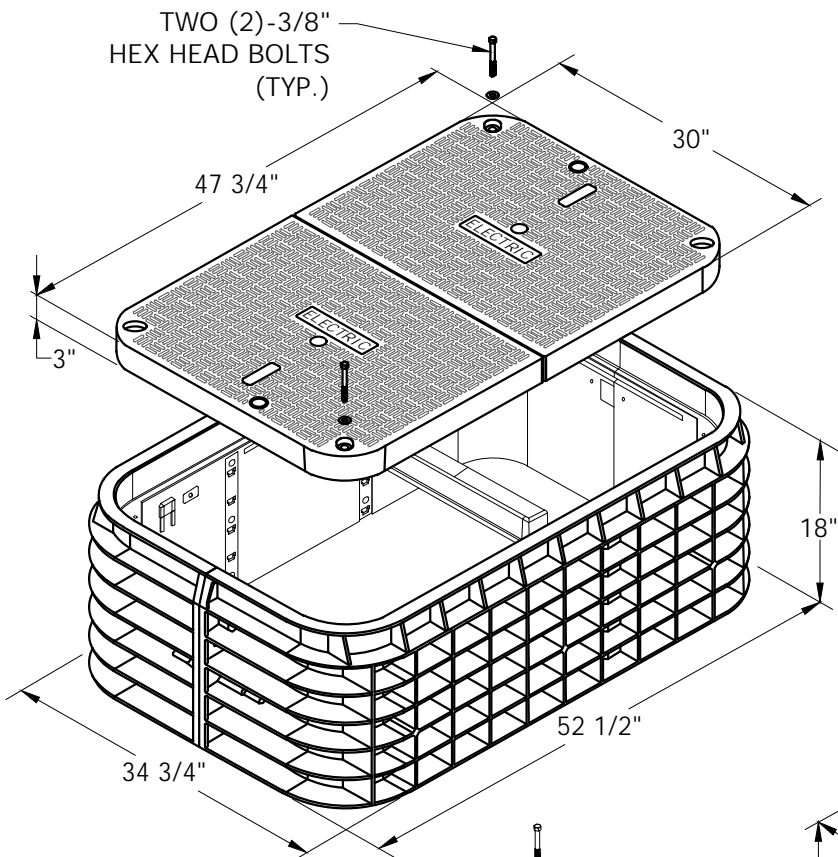

DETAIL A
JUNCTION BOX
(DIMENSIONS ARE ILLUSTRATIVE OF ONE
APPROVED MANUFACTURER AND CAN VARY SLIGHTLY)

USE: SINGLE-PHASE,
3-WIRE SERVICE
240/120V, 400A OR
LESS

SINGLE-PHASE UNDERGROUND SERVICE FROM OVERHEAD, 0-400A

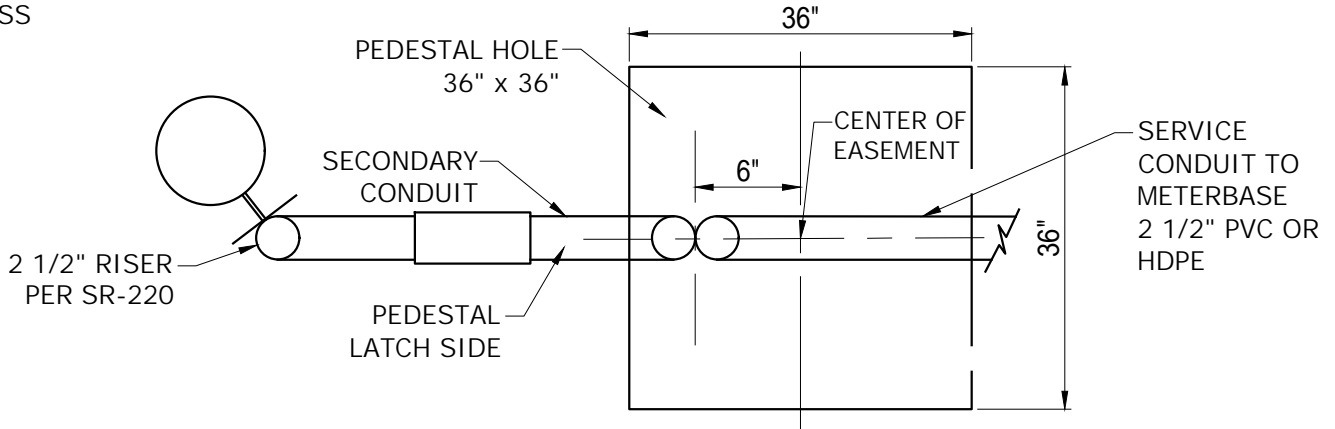

IF THE ENTIRE SERVICE CONDUIT IS NOT INSTALLED WHEN THE PEDESTAL IS, THEN A 36" X 90° SWEEP AND 5'-0" STRAIGHT (STUB-OUT) OF GREY, ELECTRICAL GRADE, SCHEDULE 40 PVC WILL BE REQUIRED. A PULL ROPE FOR THE ENTIRE SERVICE RUN PLUS 20 FEET, WILL NEED TO BE INSTALLED IN STUB-OUT. DUCT PLUGS SHALL COVER ALL CONDUITS.

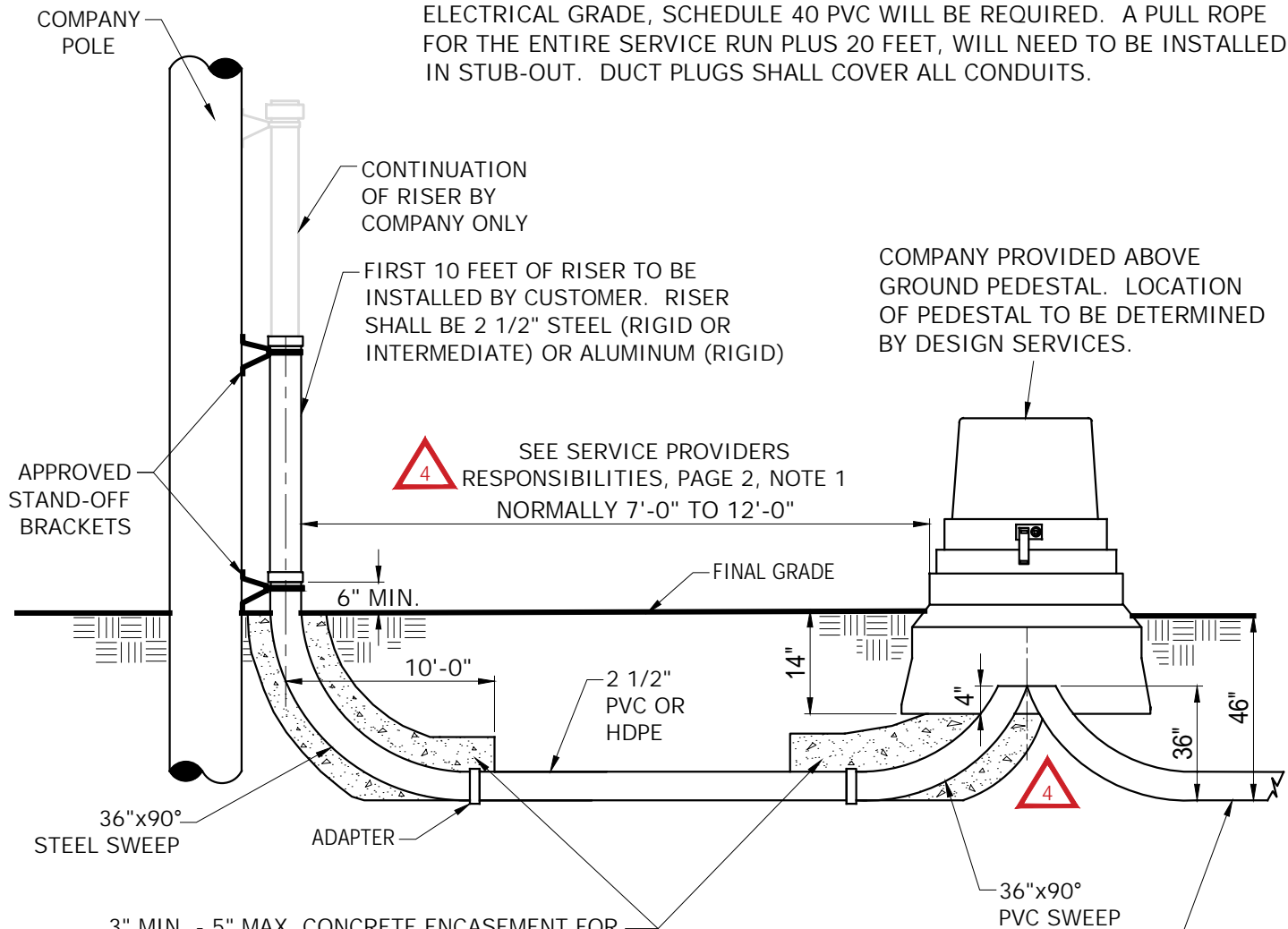

SEE SERVICE PROVIDERS RESPONSIBILITIES, PAGE 2, NOTE 1
NORMALLY 7'-0" TO 12'-0"

COMPANY PROVIDED ABOVE GROUND PEDESTAL. LOCATION OF PEDESTAL TO BE DETERMINED BY DESIGN SERVICES.

3" MIN. - 5" MAX. CONCRETE ENCASEMENT FOR ALL DUCT SIZES (SEE SR-205). CONCRETE ENCASEMENT IS REQUIRED IF A CONDUIT RUN IS MORE THAN 150 FEET IN LENGTH, OR ANY LENGTH WITH A COMBINATION OF 270 DEGREES (OR MORE) OF BENDS, NOT TO EXCEED 360 DEGREES.

NO CONCRETE IS REQUIRED WITH A CONTINUOUS WAVE-RIB INSTALLATION.

SINGLE-PHASE UNDERGROUND SERVICE FROM OVERHEAD, 0-400A



CUSTOMER RESPONSIBILITIES

1. At the specified Company pole, provide and install a 36" x 90° steel sweep and the first 10 feet length of steel (IMC or RMC) riser up the pole. From the riser extend a 2 1/2" duct system ending with a 4 inch stub above the sub-grade; within the pedestal hole. If the entire service conduit is not installed when the pedstal and secondary conduit is, then a 36" x 90° sweep and 5 feet straight (stub-out) of Grey Electrical Grade, Schedule 40 PVC will be installed. A pull rope for the entire service run plus 20 feet, will need to be intalled in the stub-out. Duct plugs shall cover all conduits. The duct installation shall meet the requirements of SR-205.

Concrete encasement is required where a duct run exceeds 150 feet, between the riser pole and the secondary pedestal, or any length with a combination of 270° (or more) of bends. Encasement will be required on the vertical sweep and for a length of 10 feet horizontal. No continuous conduit system shall exceed 360° total bends.

Rigid steel, IMC, and rigid aluminum conduit must have a protective tape applied. The tape is to be installed starting 6 inches above final grade down beyond the (Shur-Lock II or PVC) coupling joint. Use 10mil protection tape in a half lap installation.

2. The duct size shall be 2 1/2 inches for service entrance ratings of 0-400 Amps. All risers must be secured to pole with standoff brackets (see Approved Material on this page).
3. The Company will supply the customer with the above ground pedestal which the customer is to install. A one week notice is needed to allow for scheduling by Design Services. A site contact name, phone number, and location of material staging area needs to be provided when making arrangements for delivery. A signature will be required upon delivery. It is the customer's responsibility for the care of the material. Any lost or damage material will be the responsibility of the customer to replace with Company approved material.
4. Any existing cable-in-conduit (CIC) secondary or service cables that are required to be relocated to the new pedestal will require the installation of the previously specified stub out. Design Services will advise the customer on the direction of placement.
5. Refer to SR-108 for Right-of-way and Easement requirements.



6. If located in a traffic area, protective posts must be installed per SR-230.

APPROVED MATERIAL

- 2 1/2" Standoff Bracket
- Aluma-Form, Inc., Cat. No. 4-CSO-7/.STK-2.5T
- Lag Screw, 1/2" X 4"
- Riv-Nut - AB66900 (see SR-220)
- Riv-Nut Installation Tool - 131638

SERVICE PROVIDER RESPONSIBILITIES



1. Specify location for pedestal and on which quadrant pole riser is to be attached. Location of the pedestal will normally be 7 to 12 feet from pole, but should be in a non-traffic area.
2. Provide and install continuation of duct on Company pole and ground the metal riser.
3. Provide and install cable in the duct from pole to the pedestal.
4. Provide the above grade pedestal. Provide and terminate the secondary and service conductors.
5. Maintain the pedestal after the service is connected to the Company distribution system.

 Tucson Electric Power	 SANTA CRUZ COUNTY	INITIATED BY	GC	REVISION NO.	4	SR-308A Pg. 2 of 2
		ESR COMM.	6-05	ESR COMM.	7-22	
				EFFECTIVE DATE	7-22	

THREE-PHASE UNDERGROUND SERVICE FROM PAD-MOUNTED TRANSFORMER, 600A



CUSTOMER RESPONSIBILITIES

1. Provide and install an approved secondary junction box. The box size to be determined by Design Services. The junction box must include a polymer concrete cover with recessed hex head bolts. Align the junction box so that the ducts terminate at the bottom edges of the ends (the faces having the shorter dimension). The top of the box shall be flush with established final grade. See item #6 for approved manufacturers.
2. Provide and install a 4 inch duct from the bottom edge of the junction box to the Company transformer. Extend the duct into the secondary compartment of the transformer pad as depicted in SR-233, Note 2. For access to pad-mounted equipment refer to Section 100.
3. Provide and install service cable (maximum of three conductors per phase) from the service entrance to the junction box. Cut cables so that they extend to the opposite end of the junction box to provide length required for by Service Provider assembly of connections. Conductors shall not be smaller than 1/0 AWG nor larger than 600kcmil. Secure the lid to the box with hex head bolts.
4. Identify at the junction box, the neutral conductor(s) in accordance with National Electrical Code requirements.
5. Identify all conductors with phase tape to insure proper connection. Each neutral conductor from a service lateral is to be identified with an aluminum embossed permanent address tag at the box, 12 inches above the conduits.

MATERIAL & APPROVED MANUFACTURERS

FIGURE 1 - 17" x 30" Junction Box (20k Rated)

- Armorcast Products Co., Cat. No. A6001640TAX18
- Channell, Cat. No. BULKU1730180062002
- New Basis, Cat. No. FCA173018H-00042
- New Basis, Cat. No. FCA173018T-00006
- New Basis, Cat. No. PCA173018-00042
- Oldcastle, Cat. No. 17301471
- Quazite, Cat. No. A12173018A017

FIGURE 2 - 30" x 48" Junction Box (20k Rated)

- Channell, Cat. No. BULKU3048180082002
- New Basis, Cat. No. FCA304818T-00042
- New Basis, Cat. No. FCA304818T-01002

SERVICE PROVIDER RESPONSIBILITIES



6. Specify location for junction box. Junction box should be in a non-traffic area and not within a concrete slab, sidewalk, driveway or driveway path. If located in a traffic area, protective posts must be installed per SR-230.
7. Provide and install cable in the duct from transformer to junction box.
8. Provide and install connectors at junction box. The load terminals of these connectors shall be the point of delivery for this installation.
9. Maintain the junction box after the service is connected to Company distribution system.

		INITIATED BY	ES	REVISION NO.	10	SR-309 Pg. 1 of 3
		ESR COMM.	4-85	ESR COMM.	4-23	
		ESR COMM.	4-85	EFFECTIVE DATE	4-23	

USE: THREE PHASE,
4-WIRE SERVICE
208Y/120V, OR
480Y/277V, 600A

THREE-PHASE UNDERGROUND SERVICE FROM PAD MOUNTED TRANSFORMER, 600A



APPLICABLE FOR CROSSING PUBLIC RIGHT-OF-WAY

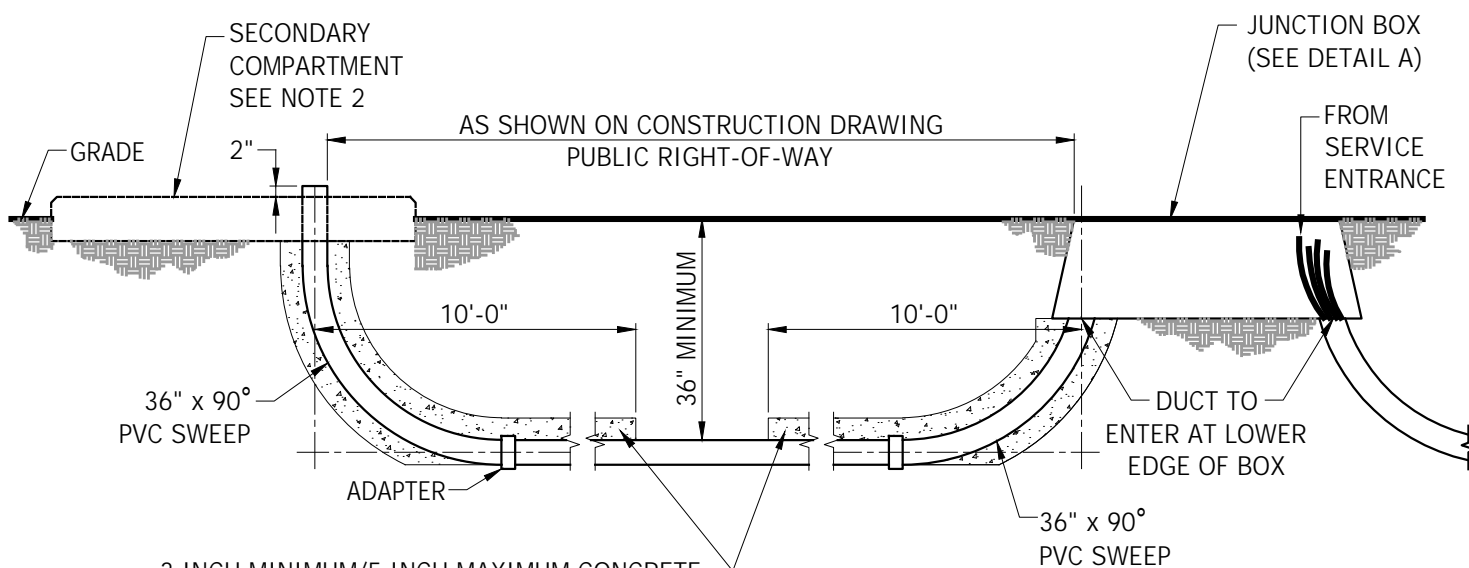

3 INCH MINIMUM/5 INCH MAXIMUM CONCRETE ENCASEMENT, FOR ALL DUCT SIZES (SEE SR-205). CONCRETE ENCASEMENT IS REQUIRED IF A CONDUIT RUN IS MORE THAN 150 FEET IN LENGTH, OR ANY LENGTH WITH A COMBINATION OF 270° (OR MORE) OF BENDS, NOT TO EXCEED 360°.

THESE REQUIREMENTS APPLY TO COMMERCIAL AND INDUSTRIAL CUSTOMERS WHO WILL BE SERVED UNDERGROUND FROM AN UNDERGROUND SYSTEM WITH THREE-PHASE SERVICE ENTRANCE EQUIPMENT RATED 600A OR LESS AND 480V OR LESS LOCATED SUCH THAT THE CUSTOMER'S SERVICE CONDUCTORS MUST CROSS PUBLIC RIGHT-OF-WAY.



USE: THREE PHASE,
4-WIRE SERVICE
208Y/120V, OR
480Y/277V, 600A

THREE-PHASE UNDERGROUND SERVICE FROM PAD MOUNTED TRANSFORMER, 600A

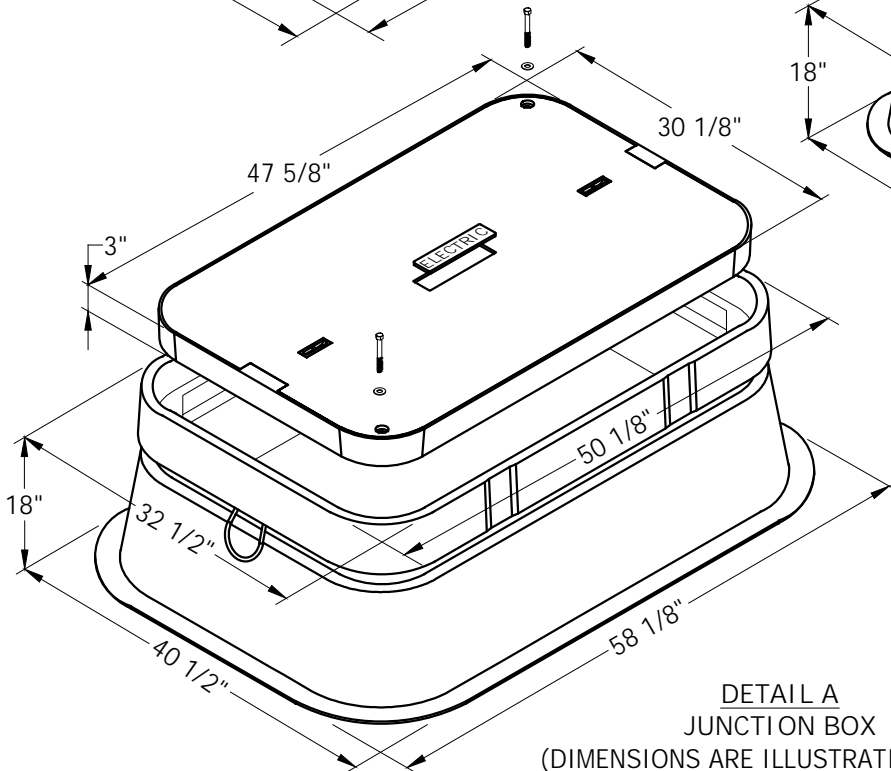
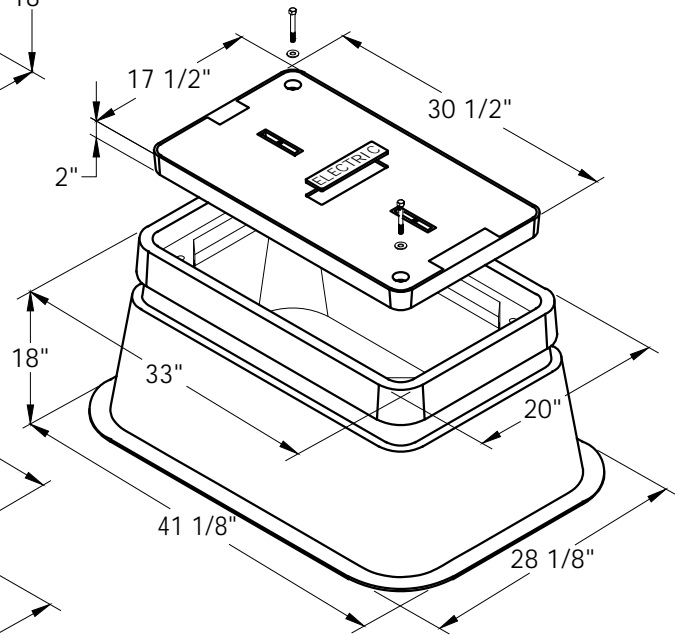
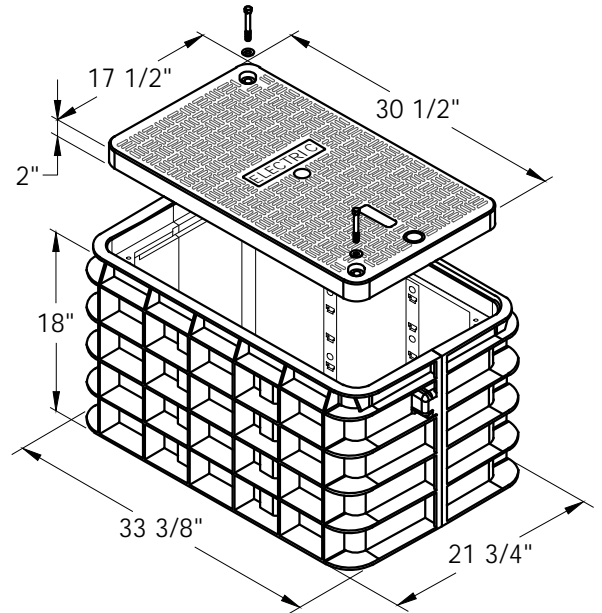
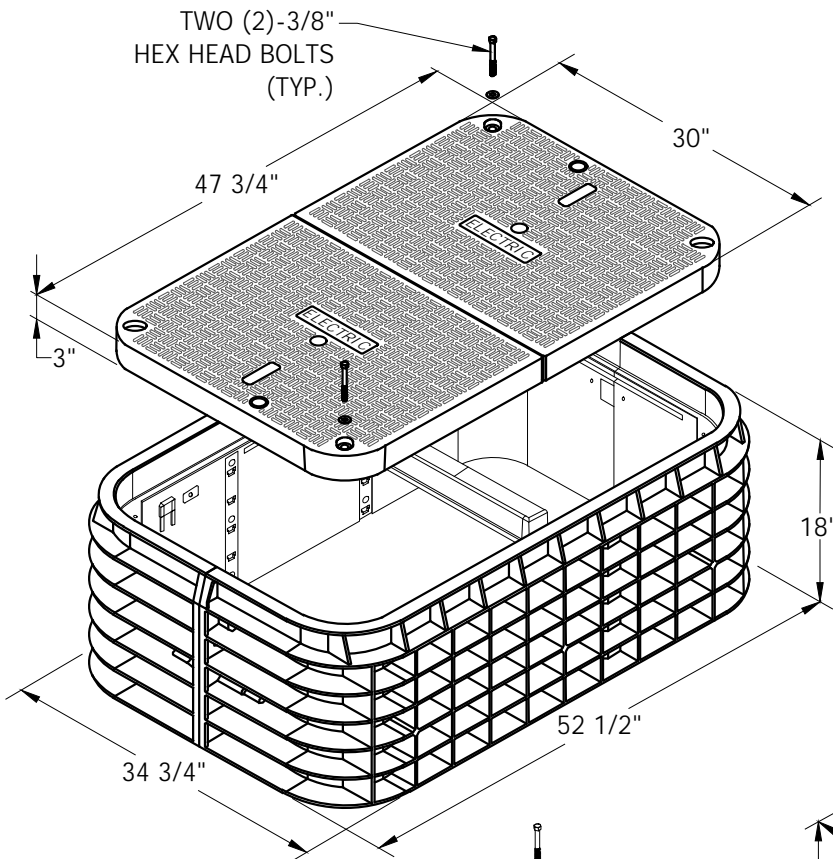

DETAIL A
JUNCTION BOX
(DIMENSIONS ARE ILLUSTRATIVE OF ONE
APPROVED MANUFACTURER AND CAN VARY SLIGHTLY)

USE: ENTRANCE
REQUIREMENTS
ON A BUILDING

SERVICE ENTRANCE
UNDERGROUND



SEE SR-304, PAGE 1 AND 2 FOR METER LOCATION

RISER NOTE:
RIGID STEEL OR IMC CONDUIT MUST HAVE A PROTECTIVE TAPE APPLIED. THE TAPE IS TO BE INSTALLED STARTING 6" ABOVE FINAL GRADE DOWN BEYOND THE HDPE, SHUR-LOCK II OR PVC COUPLING JOINT. USE 10 MIL PROTECTION TAPE IN A HALF LAP INSTALLATION.

CONDUIT NOTES:
SERVICE PROVIDER DESIGNS EXCLUSIVELY WITH A CUSTOMER PROVIDED AND INSTALLED TOTAL CONDUIT SYSTEM.
2 1/2" SCHEDULE 40 ELECTRICAL PVC OR HDPE OR 4" SCHEDULE 40 ELECTRICAL PVC FOR 401-800A, REQUIRED FOR SERVICE DUCT RUNS.

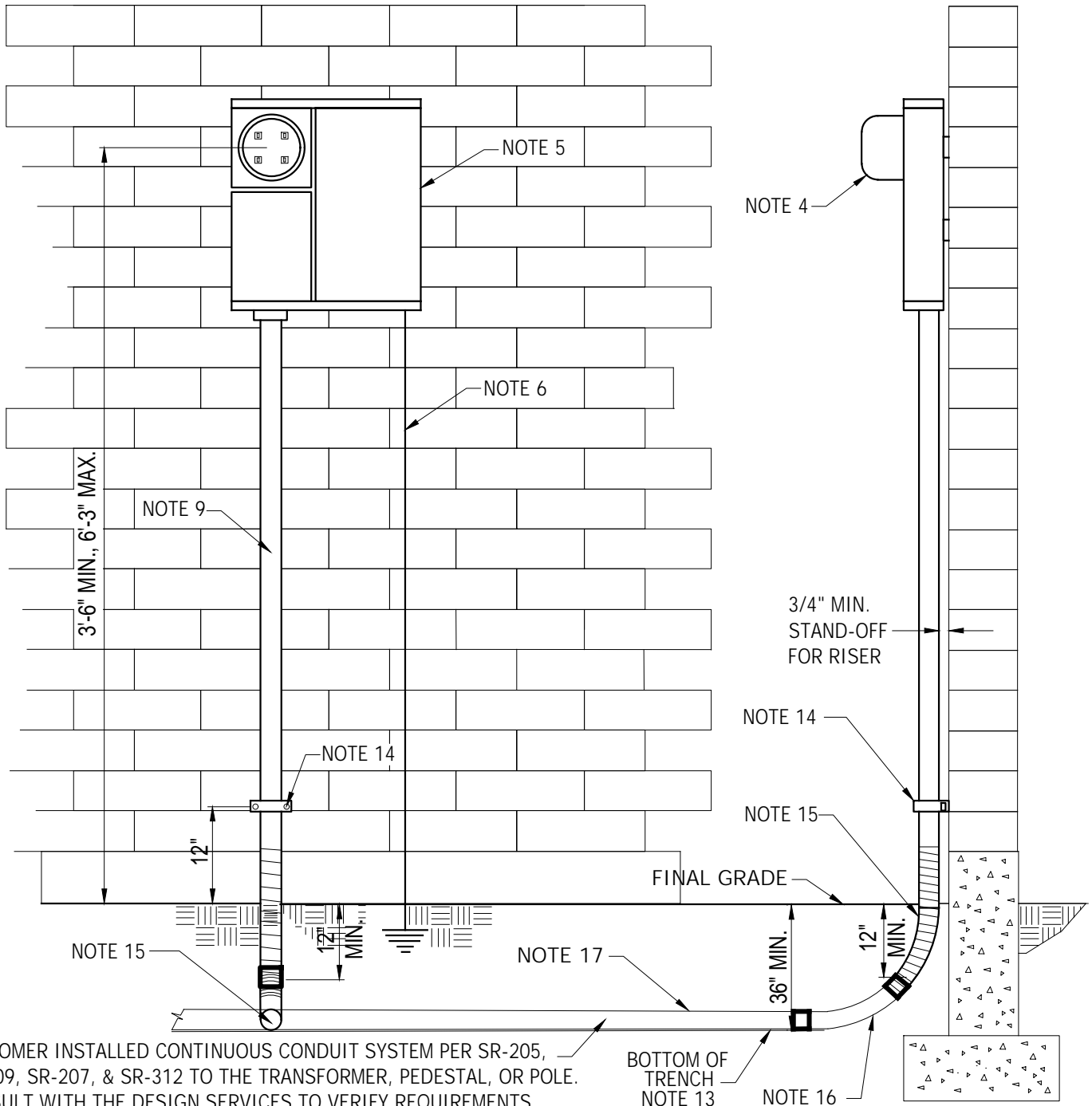

CUSTOMER INSTALLED CONTINUOUS CONDUIT SYSTEM PER SR-205, SR-209, SR-207, & SR-312 TO THE TRANSFORMER, PEDESTAL, OR POLE. CONSULT WITH THE DESIGN SERVICES TO VERIFY REQUIREMENTS.

		INITIATED BY	SC	REVISION NO.	21	SR-310
		ESR COMM.	11-68	ESR COMM.	10-24	
				EFFECTIVE DATE	10-24	

USE: ENTRANCE REQUIREMENT
ON STUB POLES
SUPPORTING PANEL
* NOT FOR USE IN
SUBDIVISIONS



SERVICE ENTRANCE UNDERGROUND



OPTIONAL LOCATION FOR 4" X 4" POST IF SERVICE IS TO BE
TRANSFERRED TO WALL OF PERMANENT BUILDING.
SEE DETAIL A BELOW

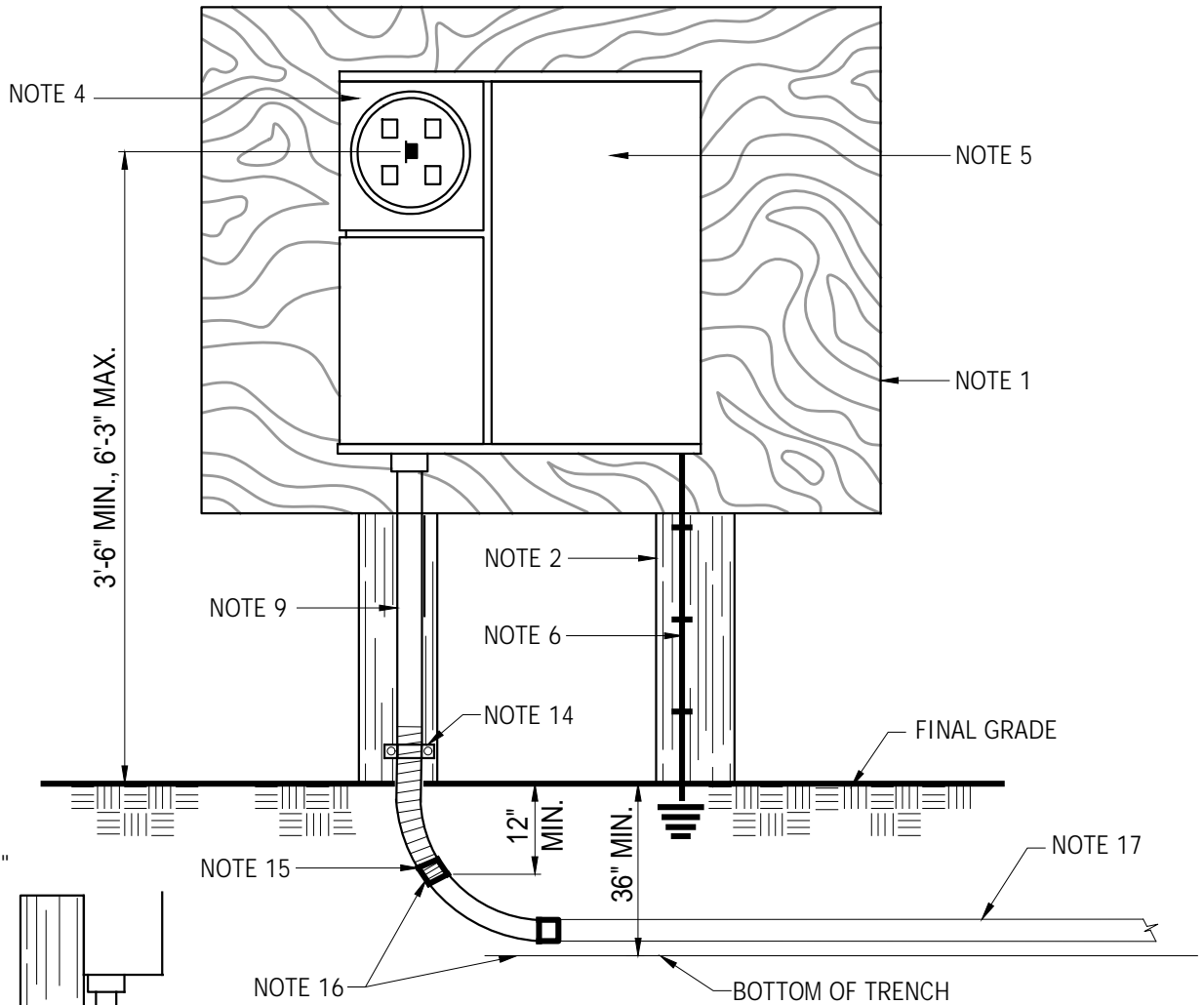
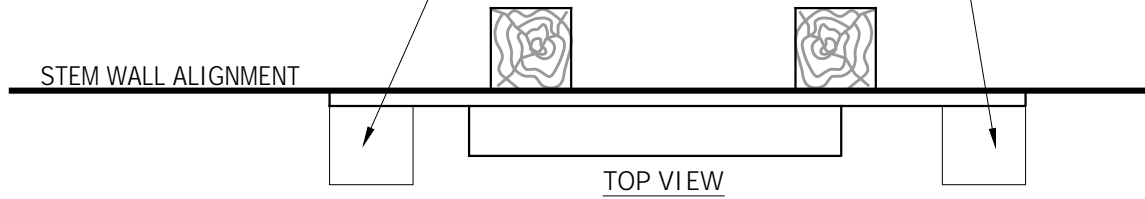

DETAIL FOR
OPTIONAL 4" x 4"
POST LOCATION

WOOD SHIM TO
SUPPORT RISER

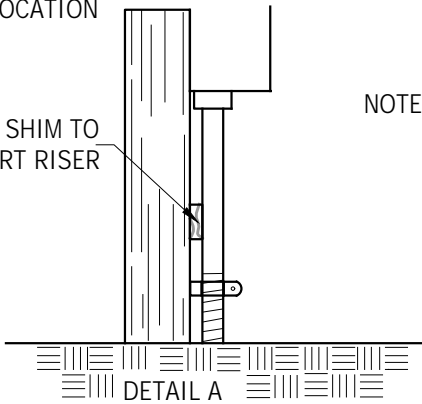

CUSTOMER INSTALLED CONTINUOUS CONDUIT SYSTEM PER SR-205,
SR-209, SR-207, & SR-312 TO THE TRANSFORMER, PEDESTAL, OR POLE.
CONSULT WITH THE DESIGN SERVICES TO VERIFY REQUIREMENTS.

2 1/2" SCHEDULE 40 ELECTRICAL PVC OR HDPE OR
4" SCHEDULE 40 ELECTRICAL PVC FOR 401-800A, REQUIRED FOR
SERVICE DUCT RUNS.



1. If utilized, a meter board 10 inch x 22 inch x 3/4 inch or larger, treated for outdoor application, shall be fastened securely to the building wall, or other support, for mounting meter sockets, switches, and any other devices necessary for adequate metering and protection. Other mounting arrangements subject to the Company's approval.
2. Where meter socket and switches are mounted on a meter board supported by two stub poles, such poles shall be a nominal 4 inch x 4 inch, and treated to resist rot and weathering. The poles shall be set sufficiently deep to provide rigid support for installation of the meter and operation of the switch. Not intended for subdivision use.
3. When meter socket and switches are securely attached to support members, they shall be securely attached by directly bolting to the metal channel or unistrut cross members. Not intended for subdivision use. Acceptable support members are as follows:
 - 3" X 3" X 1/2" Angle
 - 3" X 4.1 lbs/ft Channel
 - 2" x 2" X 3/16" Box Steel
 - 2 1/2" Standard Pipe
 - P1001 Unistrut
4. Meter and instrument transformers will be furnished by Service Provider. Meter sockets are to be purchased and installed by the customer per the SR-400 Section.
5. The customer shall provide a service disconnecting device which meets all requirements of the current National Electrical Code. The operation of the device shall be such that the neutral (grounded conductor) is not broken when the device is opened. The operating handle or member shall be capable of being sealed either open or closed.
6. The service disconnect switch shall be effectively grounded in compliance with the applicable requirements of local governmental inspection codes, or current National Electrical Code requirements in the absence of local codes.
7. All meter sockets shall be mounted between 3'-6" minimum and 6'-3" maximum from final grade to the center of the meter.
8. The service disconnect switch described in Note 4, above, may be mounted beside and separate from the meter socket.
9. The service run from the meter socket down the building wall or mounting board shall be in rigid or intermediate steel conduit (RMC or IMC), conduit shall be 2 1/2 inch for 0-400A, and 4 inch for 401-800A, with a 45 degree or 90 degree sweep into the service trench. The steel portion of the riser shall be 1 foot below the final grade. A threaded connection is required at both ends of the riser. All installations over 400A may require two 4 inch diameter PVC Schedule 40 electrical grade conduits. The customer is required to install a protective tape to the riser starting 6 inch above the final grade, then down beyond the HDPE or PVC coupling joint. The tape shall overlap the coupling joint by a minimum of 2 inches.

		INITIATED BY	SC	REVISION NO.	12	SR-310 Pg. 3 of 4
		ESR COMM.	03-78	ESR COMM.	10-24	
				EFFECTIVE DATE	10-24	



10. Single-phase service to individual residential or commercial customers, refer to SR-310, Page 1, will normally be furnished using the Company's underground cable. The customer will be required to furnish and install a continuous conduit system sized for the service entrance amperage. When total service switch capacity on existing buildings is increased beyond the capability of existing service cable sized to handle the initial switch capacity, the customer will be responsible for the cost of any trenching and duct installation which may be required to enable the Service Provide to adequately serve the increased load.
11. Single-phase service cable to apartment buildings and townhouse complexes shall be sized based on the estimated demand load. If this demand is expected to exceed the ampacity of a 2 1/2 inch conduit, then a 4 inch or two 4 inch continuous conduit system must be installed by the customer. For riser requirements at a pole, refer to SR-308A and SR-220.
12. All continuous conduit runs regardless of size, are to have a 45 degree or 90 degree sweep with a 36 inch radius at service riser, and a 90 degree sweep with a 36 inch radius at pad-mount transformer, pedestal, or pole riser. The total of all deflections within the conduit run are not to exceed 270 degrees, see Note 14 for exceptions. Refer to SR-205 for conduit requirements.
13. The service trench shall be per the Company's Service Requirement SR-312. Random lay with other utilities is acceptable with the exception of sewer. Water and gas lines shall maintain a 1 foot separation either horizontal or vertical/horizontal, other than directly above the electric facility, refer to SR-312, Page 1. Other utilities are not permitted to pass underneath any Company equipment.
14. Riser to be plumb and securely fastened to the wall or pole in such manner as to not allow movement of the riser when subjected to stresses which may be applied when installing or removing electric service conductor. Riser shall be anchored to a stud for frame stucco construction. Contact Design Services if building structure is not similar to SR-310, Page 1.
15. Align centerline of riser with the centerline of service trench. Do not aim end of riser into side of service trench. For installations using 2 1/2 inch conduit with 45 degree x 36 inch sweep, position the lower end of riser 12 inches below the final grade then transition to a Schedule 40 PVC 45 degree x 36 inch sweep and coupler or HDPE conduit with Shur-Lock II connector.
16. Trench depth to be 36 inches when installing a continuous duct system. The sweep is to be a 36 inch radius x 45 degree or 90 degree sweep.
17. 2 1/2 inch DB-120 PVC electrical conduit may be used in straight runs in service installations when the meter location is on the same side as the utility source, refer to SR-304, Page 2. The sweeps and connectors shall be Schedule 40 PVC, no greater than 270 degrees of bend within the conduit run. The maximum service length is 250 feet.
18. When cross-trenching (opposite quadrant) refer to SR-304, Page 2., 360 degree of deflections are permitted within a service run. The underground service length is to be 100 feet or less, and using Schedule 40 PVC, Wave Rib or Dura Line conduit, no DB-120 PVC is allowed. The meter will be located in front of any wall or fence.
19. Underground supply cable should not be installed within 5 feet horizontally of an above ground or in-ground swimming pool or its auxiliary equipment. Swimming pools will not be installed over electrical utility cables.
20. A new service entrance shall be installed to provide a minimum of 3 feet clearance to gas meter regulator or regulator extension vent. For clearance guidance when electric service entrance is being relocated or upgraded, refer to SR-910.

		INITIATED BY	SC	REVISION NO.	14	SR-310	
		ESR COMM.	03-78	ESR COMM.	10-24		Pg. 4 of 4
				EFFECTIVE DATE	10-24		

TRENCHING, SERVICE (SINGLE-PHASE)

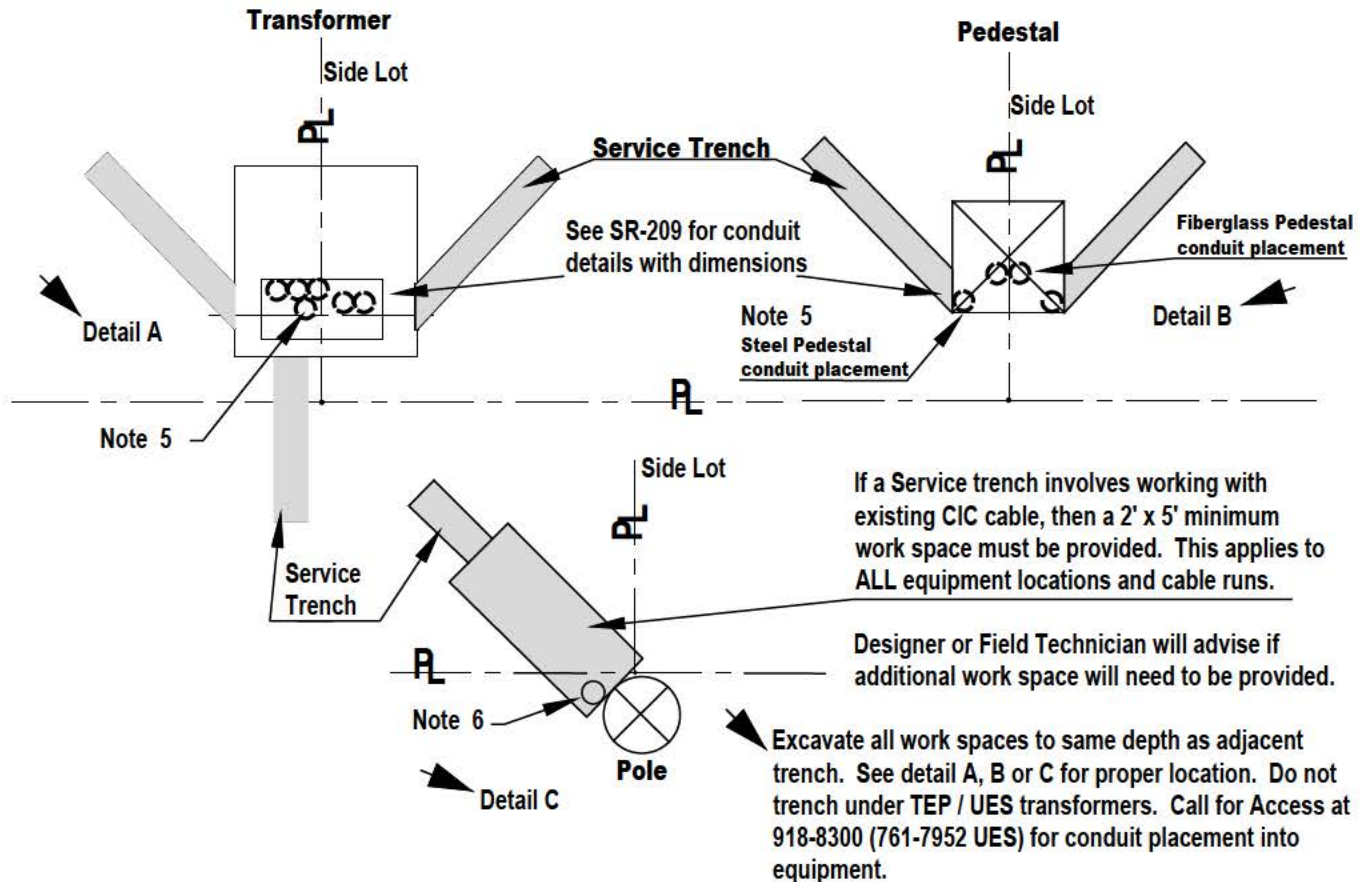
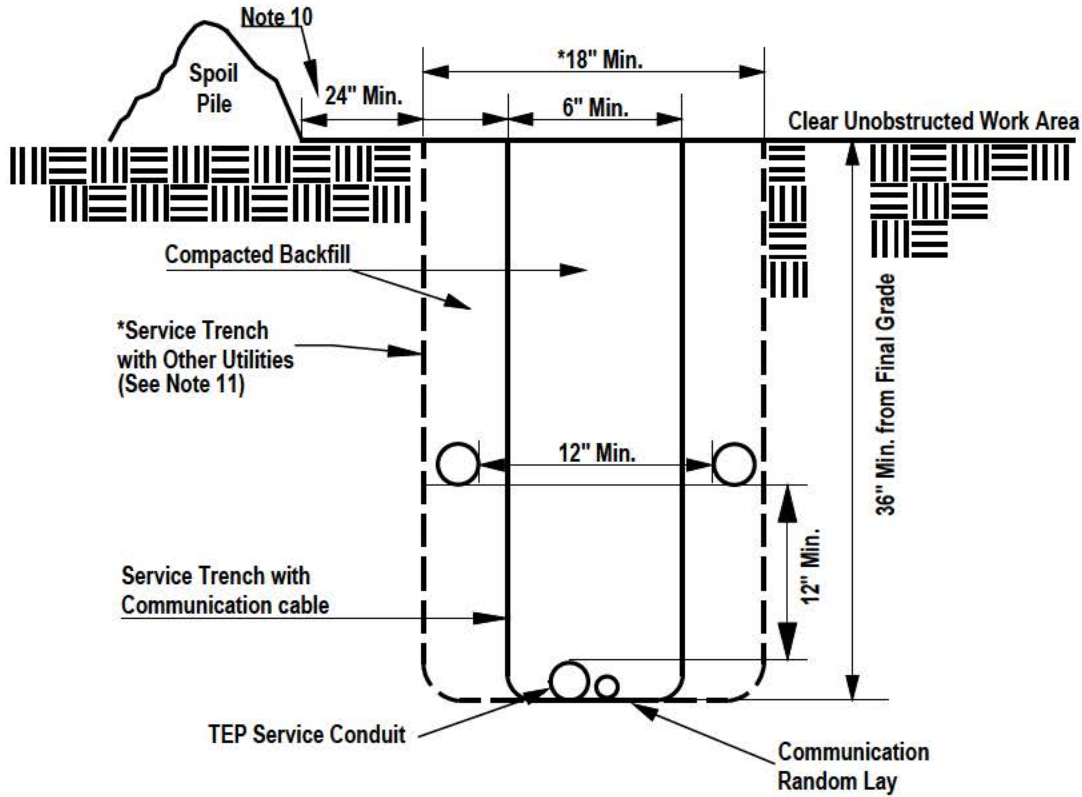

INITIATED BY	SC
STANDARDS COMM.	8-76

REVISION NO.	14
ESR COMM.	3-07
EFFECTIVE DATE	4-07

SR-312
Pg. 1 of 2

TRENCHING, SERVICE (SINGLE-PHASE)

NOTES:

1. For location of existing buried electric facilities, call Blue Stake 1-800-782-5348. Permit number for excavation within the R.O.W. will be provided to TEP prior to starting excavation.
2. Any change in location of work space or trench must be approved by the Design Department.
3. Call TEP @ 918-8300 or UES @ 761-7972 to schedule an access appointment when needing to install a conduit sweep into existing equipment in order to complete the service conduit installation. Please note that a 5 day advance scheduling notice is required.
4. The Service trench recommended width is to be 6" minimum with communication cable and 18" minimum with other utilities. The minimum depth is 36" with a 12.6' (PVC) or 4' (Wave-Rib or Dura · Line) minimum horizontal radius.
5. When installing a conduit into existing underground equipment, it must be field located in the transformer pad opening and must have a 90° sweep with a 36" radius. The trench depth is to be 36" minimum, and horizontal radius shall be 12'-6". All ducts to be 1" above the existing transformer pad or 5" above final grade where the transformer pad will be installed. The trench width is to be 12" minimum. If installing the duct into energized equipment, an access crew will be required.
6. See SR-220 if a 2.5" or 4" riser is required at a pole.
7. In all 10' strip easements, transformers and pedestals are to be located within the 4' of the easement adjacent to property.
8. Where trench cannot be left open, see SR-210 for Requirements for Installation of Sleeve(s).
9. The service trench must be backfilled completely prior to the service cable installation by TEP.
10. The excavation spoil pile must be placed a minimum 2' away from the edge of the trench. This 2' area shall be level and free of debris to permit safe footing during inspection.
11. A joint Service trench with other utilities is acceptable with the exception of sewer. Water and gas lines shall maintain a 1' separation (horizontal or vertical / horizontal) other than directly above the electric facility (see SR-312 pg. 1). Other utilities are not permitted to pass underneath any TEP equipment.
12. If only a service sweep / stub is being installed into TEP/ UES equipment, it shall be per SR-209 & SR-218. An access crew appointment is required for the conduit sweep installation. (TEP 918-8300 and UES 761-7972)

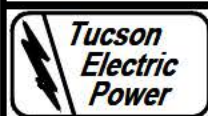

INITIATED BY	SC	REVISION NO.	8
ESR COMM.	3-76	ESR COMM.	7-12
		EFFECTIVE DATE	8-12

USE: 1Ø temporary service
 from an underground source,
 200 A max.

SERVICE ENTRANCE Temporary, Underground

Refer to SR-452 for the complete
 Approved Metering and Service
 Equipment list

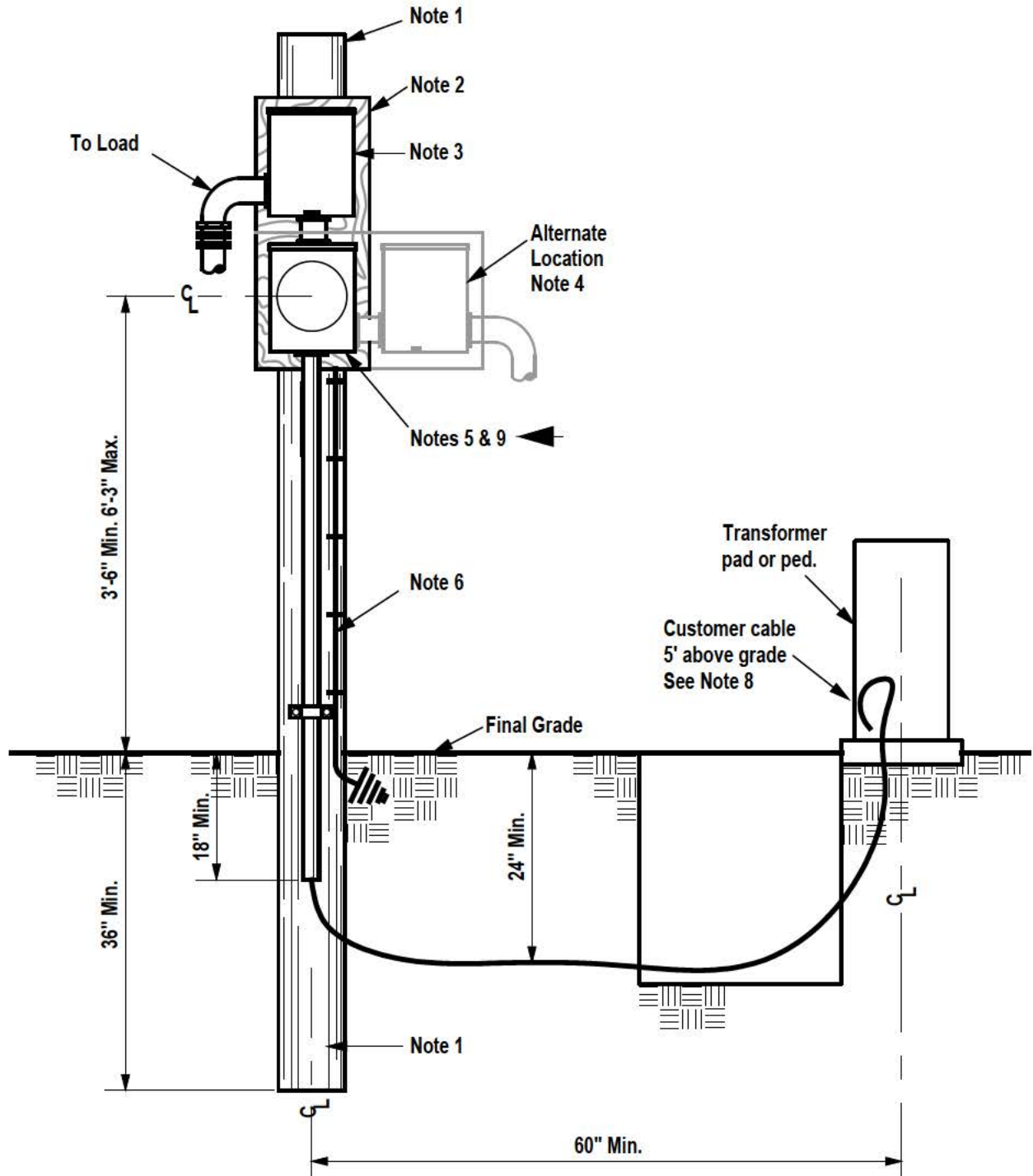

INITIATED BY	SC
STANDARDS COMM.	3-75

REVISION NO.	11
ESR COMM.	11-12
EFFECTIVE DATE	12-12

SR-314
 Pg. 1 of 2

USE: 1Ø temporary service
 from an underground source,
 200 A max.

SERVICE ENTRANCE Temporary, Underground

NOTES:

1. A service pole shall be nominal 4" x 4" or 6" diameter. The pole shall be set 3' deep.

2. A meter board 10" x 22" x 3/4" or larger, treated for outdoor application, shall be fastened securely to the pole for mounting meter sockets, switches, and any other devices necessary for adequate metering and protection.

3. The customer shall provide a service disconnecting device which meets all requirements of the current National Electrical Code. The operation of the device shall be such that the neutral (grounded conductor) is not broken when the device is opened. The operating handle or member shall be capable of being sealed either open or closed.

4. The service disconnect switch described in Note 3 above may be mounted either above or beside the meter socket as shown on Page 1.

5. Meters will be supplied by TEP or Service Provider. Meter sockets are to be furnished, installed and maintained by the customer per SR-400 Series. For 120/208V and 277/480V services, refer to SR-410 page 2 regarding five terminal sockets.

6. The service disconnect switch shall be effectively grounded in compliance with the applicable requirements of local governmental codes, or National Electrical Code requirements in the absence of local codes.

7. The service trench shall comply with local governmental codes, or National Electrical Code requirements in the absence of local codes. All trenching shall be backfilled by the customer.

8. The customer is to provide and install the temporary service cable under the supervision of a TEP/UES access crew. In some circumstances, an outage may be required. The conductor size range shall be #6 - 350kcmil in order to connect to TEP/UES underground equipment. The neutral conductor is to be identified with white tape at both ends for 3 inches in length. In addition, an address tag (Ex. Dymo aluminum embossing tape) including the word TEMP, shall be attached to the neutral conductor at the transformer or pedestal location. Direct burial conductors are allowed only upon approval by the local governing agency. The service cable shall be in compliance with the applicable requirements of local governmental codes, or National Electrical Code in the absence of local codes.

9. Panels must be identified in accordance with SR-405 'METER SOCKET AND METER SWITCH IDENTIFICATION.'

10. Temporary service duration is 2 years or less.

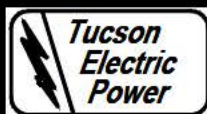

INITIATED BY	SC
STANDARDS COMM.	3-78

REVISION NO.	5
ESR COMM.	11-12
EFFECTIVE DATE	12-12

REVISION NO.	5
ESR COMM.	11-12
EFFECTIVE DATE	12-12

400 SECTION METERING INSTALLATION

<u>TITLE</u>	<u>SR-No.</u>
General Requirements (pg. 1-6)	
Definitions (pg. 7-8)	
Requirements for Residential Socket Interiors (pg. 9)	
Meter Enclosures and Clear Working Space (pg. 10)	405
Residential, Small & Permanently Unoccupied Commercial Service Entrance, 0-200A	
Socket, Class 100, 0-30A, 2W, Single-Phase, O.H. or U.G. Service (For Maintenance Only) (pg. 1)	
Socket, Class 100, 0-100A, 3W, Single-Phase, O.H. Service (pg. 1)	
Socket, Class 200, 101-200A, 3W, Single-Phase, O.H. Service (pg. 2)	
Socket, Class 200, 0-200A, 3W, Single-Phase, U.G. Service (pg. 3)	
Underground Combination Meter Socket and Distribution (pg. 4)	
Meter Post, U.G. Service to Mobile Home (pg. 5-6)	408
Service Pedestal for Use in Common Public Area & Right-of-Way, 0-200A, 0-600V	409
Commercial Service, 0-200A, 3W or 4W, Single-Phase or Three-Phase	410
Residential or Commercial Service, 201-400A, 3W, Single-Phase	412
Socket Requirements , Single-Phase or Three-Phase w/Instrument Transformers	414
Residential or Commercial Service, Multi-Metering Installations	418
Residential, High-Rise Building, Individually Metered Units	419
Metering Protective Cabinets (See Note 4 for Totalized Metering)	420
Current Transformer Installations in Cabinet	422
Meter Socket and Conduit Installation Detail for Primary Metered Service	423
Remote Meter Cabinet for Primary Metered Service, 201-800A	424
Terminating Box or Section	425
Combination Terminating Box and Main Disconnect	426
▶ Commercial CT Power and Control Cabinet, 400-800A	429
Current Transformer Installations in Switchgear	430
Metering Remote	431
Low Profile Switchboards	432
CT Compartment, 401-800A, Single-Phase	433
CT Compartment, 201-1000A, Three-Phase	434
CT Compartment, 1001-3000A, Three-Phase	435
CT Compartment, 3001-4000A, Three-Phase	436
Enclosed Meter Panel in Raintight Switchgear	437
Switchboard Meter Panels	438
Removable Bus Links and CT Supports	439
Primary Metering Overhead and Underground	451
Approved Metering and Service Equipment	452



Tucson Electric Power



SANTA CRUZ COUNTY

METERING INSTALLATION

GENERAL REQUIREMENTS



1. METER SOCKETS

Meter sockets are supplied and installed by the customer or an electrical contractor. The meter socket shall be mounted so the socket jaws are in true horizontal and vertical planes and will support the meter without tilt in any direction.

Meter sockets shall comply with applicable Company Service Requirements, per SR-400 Series and will be bonded per code.

Self-contained socket ratings:

Residential - All sockets shall have a maximum ampere rating not less than the ampacity of the main service switch. Maximum ampere rating of socket being 125 percent of continuous duty rating.

Commercial - All sockets shall have a continuous duty ampere rating not less than the ampacity of the main service switch.

2. METER SWITCH

For each and every meter, the customer or his contractor shall furnish and install a switch or other "approved disconnecting means" which shall control all of and only the energy registered by that meter. Service will not be rendered until switch is installed. The meter switch or other approved disconnecting device must have provisions for sealing it in the OFF position with a padlock seal. This may be accomplished by sealing the handle or breaker in the OFF position or by placing the handle or breaker in the OFF position and sealing the cover of the meter switch. Pull Out fused disconnects are not allowed. In the latter case, each meter switch must be individually covered. The meter switch shall be bonded per code. Meter switch panel designs that circumvent the locking mechanism of the door or switch, by means of removing the panel cover are not approved for installation. This requirement applies to all switchboards, stand-alone, and switchgear installations.

3. METER SWITCH LOCATION WITH RESPECT TO METER

Every meter switch installed on a service of less than 600V shall be on the load side of the meter or metering equipment.

For residential service installations, the switch must be located outside in the immediate vicinity of the meter socket and accessible from the same working area as the meter socket.

For commercial installations, the switch may be located in an Equipment Room, as described on Page 7 or a Meter Room, as described on Page 8. However, if the switch is installed outside, it must be located in the immediate vicinity of the meter socket, the same as for residential services.



For 480V 3-phase switchboards or switchgear containing a self contained meter or multiple self-contained meters, a circuit breaker(s) shall be installed on the source side of the meter equipment. The circuit breaker(s) shall be sized to limit available arc flash incident energy at the metering equipment to less than 8 calories/cm². The switchboard or switchgear shall have appropriate arc flash labeling, including all information required by OSHA. The circuit breaker(s) shall be installed in a cubicle with a panel designed to be sealed with a Company lock, but allowing the breaker operating handle to remain exposed for manual trip and reset operations.

		INITIATED BY	SC	REVISION NO.	14	SR-405 Pg. 1 of 10
		ESR COMM.	8-77	ESR COMM.	3-23	
				EFFECTIVE DATE	3-23	

METERING INSTALLATION



GENERAL REQUIREMENTS

4. MAXIMUM AND MINIMUM SOCKET HEIGHTS

Maximum height to center of socket is six feet, three inches. Minimum height to center of socket is three feet, six inches. When a meter room is provided, the minimum height shall be three feet, except for multi-meter packs for which the minimum height is permitted to be two feet, six inches.

5. METER SOCKET AND METER SWITCH IDENTIFICATION

Residential, apartments and commercial service entrances shall have the complete street address of premises where new service is required plainly displayed. The address is to be placed on the front of the building and at each apartment or suite in plain view. For individual residential homes permanent addressing is required at the service entrance (See below for permanent identification requirements).

For apartment buildings and commercial buildings, TEP will not install service until all switches, meter sockets and interior distribution panels (first sub-panel) are permanently identified and the wiring from the multi-meter pack to the interior distribution panel is installed and terminated. Interior distribution panels (first sub-panel) will be labeled on the panel door and on the back or side of the interior of the panel (See below for permanent identification requirements).

Permanent identification for switches, meter sockets and interior distribution panels shall be made with metal tags with raised letters and/or numbers no smaller than 1/2 inch. Identification labeling must maintain identity after being painted and shall be attached with rivets or screws. Apartment and commercial unit door labeling will be no smaller than 3/4 inch.

When all of the meters in a multi-meter pack are scheduled to be set, Company's Meter Department will require the assistance of the customer, customer's agent or Service Provider prior to the setting of meters to verify that each meter socket is for the unit served through the socket.

6. METER ROOM



Meters and metering equipment may be grouped in an accessible meter room. Service Provider must have unrestricted access to meter room(s) to facilitate reading and testing of meters. (See Meter Room defined on Page 8)

7. SEALING OF TERMINATING PULL BOXES, RACEWAYS, ETC.

All terminating pull boxes, raceways, etc., installed on the line side of meter sockets shall have provisions for sealing with a padlock and/or wire seal.



Access plates are required to cover hubs, knockouts or non-factory created holes entering the Companies section of metering equipment. The opening must be secured with an access plate that is rainproof and can be secured with an internal wingnut bar that spans beyond the opening. A carriage bolt must be installed from the external side of the plate and be long enough to be properly secured on the inside of the box, meter socket or raceway.

 Tucson Electric Power		INITIATED BY	SC	REVISION NO.	12	SR-405 Pg. 2 of 10
		ESR COMM.	3-77	ESR COMM.	9-20	
				EFFECTIVE DATE	9-20	

METERING INSTALLATION



GENERAL REQUIREMENTS

8. SEALS



Service Provider will seal all meter rings and devices mentioned in Requirement 7. The seal is a bond of mutual protection for the Service Provider and the customer. It may not be broken by anyone except Company personnel and persons provided permission by the Service Provider. If it becomes necessary for an electrician to access an enclosure which has been sealed by the Service Provider, customer must call to schedule a Power Kill a minimum of 5 working days prior to the time the access is required, refer to SR-106 for additional detail. Seals installed by the Company will have the Company name identified on the seal.

9. METER AND/OR INSTRUMENT TRANSFORMER CABINET LOCATIONS





Meter equipment shall be installed on an exterior wall and will be accessible for reading and testing without entering the building. With approval from Design Services meter(s) and metering equipment may be grouped in an accessible meter room. See Meter Room, Requirement 6 and Meter Room Definition, SR-405, Page 8, for additional information.

10. PROHIBITED METER AND/OR INSTRUMENT TRANSFORMER CABINET LOCATIONS

In the interest of providing service to our customers and safe working conditions for our employees, certain locations for equipment installations shall be prohibited. Meters and associated equipment shall not be installed in the following locations unless prior approval is given by Design Services.

- A. In any rest, bath, shower, or toilet room.
- B. Directly over any door, window, stairway, ramp, or steps.
- C. In any hazardous location.
- D. On any roof, attic, or place not in general use.
- E. In any basement.
- F. In any equipment room.
- G. Approval of locations D, E, and F will be based on the following facts:
 - 1) The meter and metering equipment are readily accessible for reading and testing, and access to them does not require procuring a key from the customer or permission to enter on each occasion. If, for any reason the customer (original or future) decides to stop Service Provider access to a metering location, the meter and metering equipment must be moved to a new approved location at the customer's expense.
 - 2) The location shall not be used to store valuable merchandise, equipment, etc.
 - 3) The location does not require Company employees to take hazardous or time consuming methods to gain access.
 - 4) The location is not a high security area with restricted access.



		INITIATED BY	SC	REVISION NO.	10	SR-405 Pg. 3 of 10
		ESR COMM.	8-77	ESR COMM.	8-20	
				EFFECTIVE DATE	8-20	



METERING INSTALLATION



GENERAL REQUIREMENTS

10. PROHIBITED METER AND/OR INSTRUMENT TRANSFORMER CABINET LOCATIONS (CONTINUED)

- H. Any location where moisture, fumes, vibrations, or dust may interfere with the operation or materially damage the meter or metering equipment or may present a hazard to Company employees.
- I. In any substation or transformer vault, unless the meter is in an enclosure which is effectively screened from the high voltage compartment and contains no bare or exposed energized parts. Entry to vaults must be through normal doorways, not manholes, etc.
- J. In any enclosed show window or one having a raised platform or behind a sales counter.
- K. In or on any transformer cabinet, unless specifically designed and approved for that purpose.
-  L. Under any carport, breezeway, patio, porch or area that can be enclosed with building expansion. Existing overhead type service entrances may remain under a carport, breezeway, patio or porch unless the area is to be enclosed. Underground type service entrances must be relocated if the service is upgraded. All residential service types must be relocated if the service entrance is enclosed within any room, garage, screened in area, etc..
- M. In any school building hallway subject to student traffic.
- N. Any location subject to vehicular traffic which will present a hazard to the meter, meter readers, or service men, such as driveways, loading docks, etc.
- O. Any location where at least three feet of working clearance is not provided in front of all meter equipment.
- P. Any location that will require reading or servicing from within the fenced portion of a freeway.
- Q. In any area where a door swings and could result in damage to equipment or prevent safe operation.
- R. In any elevator shaft or hatchway.
- S. On any surface subject to excessive vibration.
- T. In any projection room.
- U. Directly over any stove or plumbing fixture.
- V. On any balcony or mezzanine floor, unless such balcony or mezzanine floor has a clear stairway of normal tread or rise and with utility approval.
- W. On the front exterior wall of a residence, unless mutually agreed to by the home builder, or customer and Service Provider. Other locations may be deemed prohibited, by Design Services, because of hazardous conditions or inaccessibility.
-  X. Any floor above ground floor or sub-grade, without prior approval from Service Provider, except as allowed per SR-419.
- Y. On or enclosed in any bedroom wall or bedroom closet wall.
- Z. On or recessed in the external surface of any building that is built within 3 feet of any property line or inline with any walk, alley, or driveway giving access to commercial or Industrial property. Other locations may be deemed prohibited, by Design Services, because of hazardous conditions or inaccessibility.

 	INITIATED BY	SC	REVISION NO.	13	SR-405 Pg. 4 of 10
	ESR COMM.	8-77	ESR COMM.	11-21	
			EFFECTIVE DATE	11-21	

METERING INSTALLATION



GENERAL REQUIREMENTS

11. WORKING SPACE

A level standing and working surface shall be provided and maintained in front of each metering installation. The service trench will be backfilled to final grade before calling for a metering inspection. The meter height is to be 3'-6" minimum and cannot exceed 6'-3". A clear and unobstructed working space shall be provided above the surface. The width of the working space shall be sufficient to permit ready access to the metering equipment and in no case less than 3 feet. The height of the working space shall be no less than 7 feet. The working space shall extend at least 3 feet in front of the surface on which the metering equipment is mounted and no less than 10 inches from the meter centerline to any obstruction such as walls, plants or trees, see SR-405, Page 10, for additional information.

12. PROTECTION OF METERS AND METERING EQUIPMENT

In the interest of public safety and to prevent destruction of the customer's meter socket and Service Provider's meter, the customer when instructed by the Company shall provide and install a protective cabinet for enclosure of the socket and meter. This requirement shall be mandatory for installations located in parks or school yards. (See SR-420, Page 1, Meter Enclosure Cabinets.)

13. SEPARATION OF WIRING

Unmetered customer service wires and metered load wires are not to be run in the same conduit, raceway, or wiring gutter. Metered and un-metered wires shall be separated by suitable barriers. Metered wires from the customer's distribution section (branch circuits) shall not pass through sealable sections.

14. GROUNDING

The meter socket or enclosure shall be effectively grounded in compliance with applicable requirements of local governmental inspection codes, or National Electrical Code requirements in the absence of local codes.

15. SERVICE REPLACEMENT, UPGRADE OR RELOCATION

Where the meter or service line location on the Customer's premises is changed at the request of the Customer or due to alterations on the Customer's premises, the Customer, at his expense, must provide and have installed all wiring and equipment necessary for relocating the service entrance and service line connection. The Company will assess a charge for moving the meter and/or service line. Where the customer alters his premises, the relocation of the service line and/or meter is at the Customer's expense.



All efforts shall be made to insure the existing underground service conductors terminate on the manufactured connector in the new service panel. In the event the existing service conductors are insufficient in length, the Company may install a splice in the customer's pull section or within Company equipment to restore power to the customer. Splices will not be installed in inaccessible areas or within conduit systems. At the Company's discretion, the customer may be required to lower the service entrance to obtain sufficient length or provide a new conduit system and service riser from the service entrance to the Company equipment. Meter sockets that are lowered must still maintain the minimum height requirement of 3'-6" from final grade to center of the socket or they will not be approved. If the existing service conductor is damaged and meets the Service Provider's required design criteria, the replacement of the conductor will be billable.

Current transformers (CTs) used for transformer-rated metered services are no longer allowed in the secondary compartment of the Service Provider's three-phase pad-mount transformers. Upgrades or replacements of this service type require removal of CTs from the transformer and installation in an approved customer installed CT cabinet or switchgear section. Refer to SR-422 and SR-430 for additional information.

		INITIATED BY	SC	REVISION NO.	15	SR-405	
		ESR COMM.	8-77	ESR COMM.	7-23		Pg. 5 of 10
				EFFECTIVE DATE	7-23		

METERING INSTALLATION



GENERAL REQUIREMENTS

16. COLOR CODING FOR THREE-PHASE SERVICE CONDUCTORS

Wiring shall be color coded as follows:

PHASE	208/120V	240/120V	480/277V
A	BLACK	BLACK	BROWN
B	RED	ORANGE	ORANGE
C	BLUE	BLUE	YELLOW
NEUTRAL	WHITE	WHITE	GRAY
GROUND	GREEN	GREEN	GREEN

The service conductors shall be marked (taped) at the source and at the termination can or CT can. Start the marking tape 6 inches from the end of the conduit and for minimum of 4 inches. Each Neutral will have a complete addressed 1/2 inch DYMO aluminum label installed above this area facing out, so it can be read when accessing the cabinet compartment.

NOTE:

As a reminder when marking the power leg inside of a 240/120V or 480/240V safety socket box, place the conductor in the far right hand side of the safety socket box. Refer to SR-410, Page 3 Note 11, Page 7 Note 8 and Page 10 Note 11.

17. ATTACHMENTS TO OR COVERING OF COMPANY METERS

Unless granted prior permission from the Service Provider, Customer shall not cover or attach anything to any Company meter.

18. DAMAGE TO UNDERGROUND CONDUCTOR



If the existing service conductor is damaged and meets the Service Provider's required design criteria, the replacement of the conductor will be billable. Customer may also be responsible for installing and updating service and conduit system to align with current standards and design criteria. The Company will not allow splices on damaged underground service conductor.

METERING INSTALLATION



DEFINITIONS

ABOVE GROUND PEDESTAL (J-BOX): Houses secondary to service cable connections typically in residential subdivisions.

AGENCY CLEARANCE: The approval of an electrical installation by the governmental agency having jurisdiction as an indication of compliance with its standards.

AMPS INTERRUPTING CURRENT (AIC OR SHORT CIRCUIT DUTY): The device rating to safely interrupt the flow of fault current.

ALL-IN-ONE SERVICE ENTRANCE SECTION (SES): Equipment manufactured as one unit.

AMERICAN WIRE GAUGE (AWG): The AWG assigns a number to a particular size of wire according to circular mill area to a maximum size of #0000.

AGENCY CLEARANCE: The approval of an electrical installation by the governmental agency having jurisdiction as an indication of compliance with its standards.

CONTINUOUS DUTY RATING: Operation at a substantially constant load for an indefinitely long time.

CONTINUOUS LOAD: A load where the maximum current is expected to continue for three hours or more.

CURRENT OR VOLTAGE TRANSFORMERS (CT AND VT) INSTRUMENT TRANSFORMERS: Transformers used to change electric current or voltage to values suitable for use in metering the consumption of electric energy. These are owned, furnished and installed by the Company.

CT CABINET OR CAN (INSTRUMENT TRANSFORMER ENCLOSURE): In general, a metal cabinet owned and furnished by the customer, installed by the customer's electrical contractor, for use by the Company to enclose the Company's instrument transformers. Only CT cans approved by the Company and meeting Company specifications may be installed.

EMT: Electrical Metallic Tubing

EQUIPMENT ROOMS (COMMERCIAL AND INDUSTRIAL): An equipment room is an illuminated room provided by the customer for the customer's service entrance equipment. The room doesn't have a doorway opening to the outside of the building or into a public hallway; therefore, the Service Provider's meter or meters must be located on an outside wall in the immediate proximity of the equipment room. Service Provider must have access to the equipment room during normal working hours.

ELECTRIC UTILITY SERVICE EQUIPMENT REQUIREMENTS COMMITTEE (EUSER or EUSERC): The EUSER Committee is an organization comprised of utility representatives from the Western Section of the United States which works to promote the standardization of electric service requirements and the design and engineering of metering and service equipment.

FAULT CURRENT: The short circuit amperage current produced during the unintentional contact of two parts of an electrical circuit that offers an alternate path for current to flow.

GENERAL PUBLIC AREA: An area where the general public has free access.

GROUNDING: Connected to earth or to some conducting body that serves in place of earth.

GROUNDING CONDUCTOR: A system or circuit conductor that is intentionally grounded.

GROUNDING CONDUCTOR: A conductor used to connect equipment or the grounded circuit of a wiring system to a grounding electrode or electrodes.

GROUNDING ELECTRODE: A ground electrode (rod) driven into earth to provide a base reference for voltage and a path to ground for fault current.

IMPAIRED CLEARANCE: The condition where a customer's structure(s), including, but not limited to, buildings, signs, towers, poles, fencing and swimming pools, is in a position or manner in which insufficient clearance, as specified by any applicable local code(s) and the National Electric Safety Code, as such codes now exist or as such codes may be amended, exists between the structure and the Company's existing transmission, substation, express feeder, street light or distribution line facilities, or any combination thereof.

		INITIATED BY	GC	REVISION NO.	10	SR-405
		ESR COMM.	8-77	ESR COMM.	8-20	
				EFFECTIVE DATE	8-20	

METERING INSTALLATION



DEFINITIONS

INSTRUMENT TRANSFORMER COMPARTMENT OR CABINET: The Company requires a compartment in the service entrance equipment, or a separate cabinet furnished by the customer for the installation of the Service Provider's current transformers and, in some cases, voltage transformers. The compartment or cabinet is for Service Provider use only and shall be locked and/or sealed Company seals and locking devices. Contact Service Provider for their requirements. The compartment or cabinet shall not be used as a raceway for customer load conductors, other service conductors or any other equipment. The compartment or cabinet is to be used solely for Company equipment.

INSTRUMENT TRANSFORMER METERING: Instrument transformers are used when either the current or voltage of a service is too great for a meter supplied by the Service Provider to be installed as a self-contained meter. Current and voltage transformers have "secondary" windings in which the current or voltage is reduced by known ratios from that of the incoming service. These smaller voltages and/or currents are applied to an "instrument-rated" meter, the readings of which must be multiplied by a constant to obtain actual usage of the service. Instrument transformers are normally used on voltages above the nominal 480V level, on 480V services with 201 amps or more and on 208Y/120V or 120/240V services with 201 amps or more.

LOAD: The ratings of the power consuming apparatus which may be connected to the Service Provider's installation or system under consideration.

MANUAL BYPASS: A mechanical jumper installed by a technician to keep the customer in service while a meter is removed for inspection or exchange.

METER ROOM (COMMERCIAL AND INDUSTRIAL): A meter room is an accessible, illuminated room provided by the customer for the location of the customer's electric service and metering equipment and for the installation of the Service Provider's meter(s). The meter room may not be used for communication equipment. The meter room shall not be used for storage, and the working space is to be kept clear and unobstructed. Meter rooms shall be provided with a doorway opening to the outside of the building or into a public hallway. Meter rooms are not required to be locked. If a meter room must be locked, a push-button wall mount key lock box will be provided to customer for installation to provide unrestricted access to the Service Provider. Upon notification Design Services will provide the required number of key lock box(es) to the customer to be securely attached on the exterior wall, within 12 inches of each meter room door. A key for the door shall be provided to the Service Provider for placement in the key lock box, prior to energizing of meter equipment. It is the responsibility of the customer to ensure that if a door lock is changed a new key is provided to the Company. The customer is to ensure that any locking mechanism on a meter room door(s) is in compliance with any Federal or State Fire Code Requirements.

METER ENCLOSURE: A Company approved metal cabinet owned and furnished by the customer and installed by the customer to enclose the Company's metering equipment. Meter enclosures will be sealed by the Company with an approved seal or lock.

POWER LEG (WILD LEG): The "C" (third) phase of a 4-wire delta secondary service shall be marked "orange". Orange colored vinyl electrical tape is an acceptable means for marking the conductor.

SECURELY ATTACHED: Attached to withstand anticipated loads and not subject to loosening.

SELF-CONTAINED METERING: A self-contained meter is one which, when installed on a socket or mounting device, is capable of carrying the total current of the service supplied to the customer and of being directly connected to the line voltage of the service.

SERVICE ENERGIZATION: The connection of a service to a voltage source.

TYPE OF SERVICE: The characteristics of electric service described in terms of voltage, phase, frequency and number of wires.

WILD LEG: See "POWER LEG".

WITHSTAND CURRENT RATING: The maximum fault current rating that the device is rated to withstand.

		INITIATED BY	GC	REVISION NO.	4	SR-405
		ESR COMM.	2-06	ESR COMM.	8-20	
				EFFECTIVE DATE	8-20	

USE: REQUIREMENTS FOR
RESIDENTIAL SOCKET
MAXIMUM 200 AMP SERVICE

METERING INSTALLATION

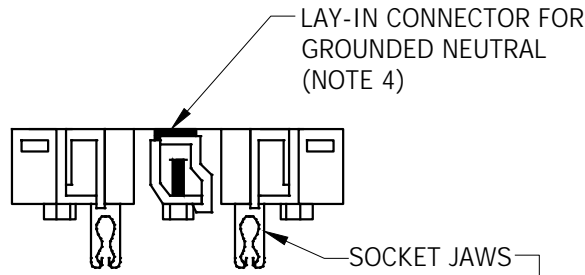

FIGURE 1
TOP VIEW

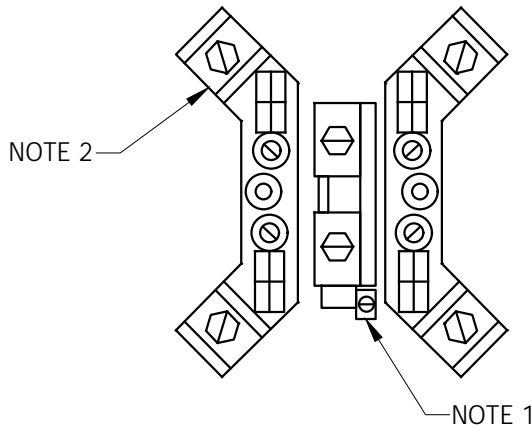

FIGURE 3
FRONT VIEW

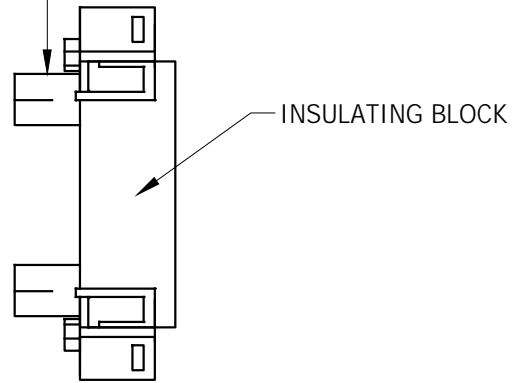

FIGURE 2
SIDE VIEW

NOTES:

1. NEUTRAL TAP REQUIRED FOR 5 JAW SOCKETS ONLY, 120/208V, SINGLE-PHASE.
2. FOR UNDERGROUND SERVICE, LINE SIDE CONNECTORS MUST BE LAY-IN TYPE APPROVED FOR COPPER OR ALUMINUM CONDUCTOR AND SHALL BE CAPABLE OF ACCEPTING #6-1/0 AWG (100A) OR 1/0AWG-250kcmil (200A). FOR OVERHEAD SERVICE, THEY MUST ACCOMMODATE CUSTOMER'S LINE AND LOAD CONDUCTORS WITHOUT REMOVAL OF STRANDS FROM ENDS OF CONDUCTORS.
3. SOCKETS MUST CONFORM TO ANSI C12.7 AND BE LISTED BY A QUALIFIED ELECTRICAL TESTING LABORATORY PER NEC.
4. FOR UNDERGROUND SERVICE, THE LAY-IN CONNECTOR FOR GROUNDED NEUTRAL MUST BE SUITABLE TO TERMINATE LINE AND LOAD NEUTRAL CONDUCTORS IN THE SOCKET AND SHALL BE BONDED TO ENCLOSURE. LINE SIDE NEUTRAL CONNECTOR MUST BE APPROVED FOR COPPER AND ALUMINUM CONDUCTOR AND ACCEPT 1/0-3/0 AWG CONDUCTOR.
5. RESIDENTIAL SOCKETS SHALL HAVE A MAXIMUM AMPERE RATING NOT LESS THAN THE RATING OF THE MAIN SWITCH OR SERVICE EQUIPMENT. MAXIMUM AMPERE RATING OF SOCKET IS 125 PERCENT OF THE CONTINUOUS DUTY RATING.
6. ONLY RING-TYPE SOCKETS WILL BE APPROVED.
7. SOCKET COVER SHALL NOT BE REMOVABLE WITHOUT REMOVING METER. LATCHING DEVICE OR MOUNTING SCREWS SHALL BE ACCESSIBLE ONLY AFTER METER IS REMOVED. SEE SR-418 FOR METER PACK REQUIREMENTS.

USE: SPECIFICATIONS FOR
METER ENCLOSURES AND
CLEAR WORKING SPACE

METERING INSTALLATION



EUSERC DWG. NO. G6 & G7

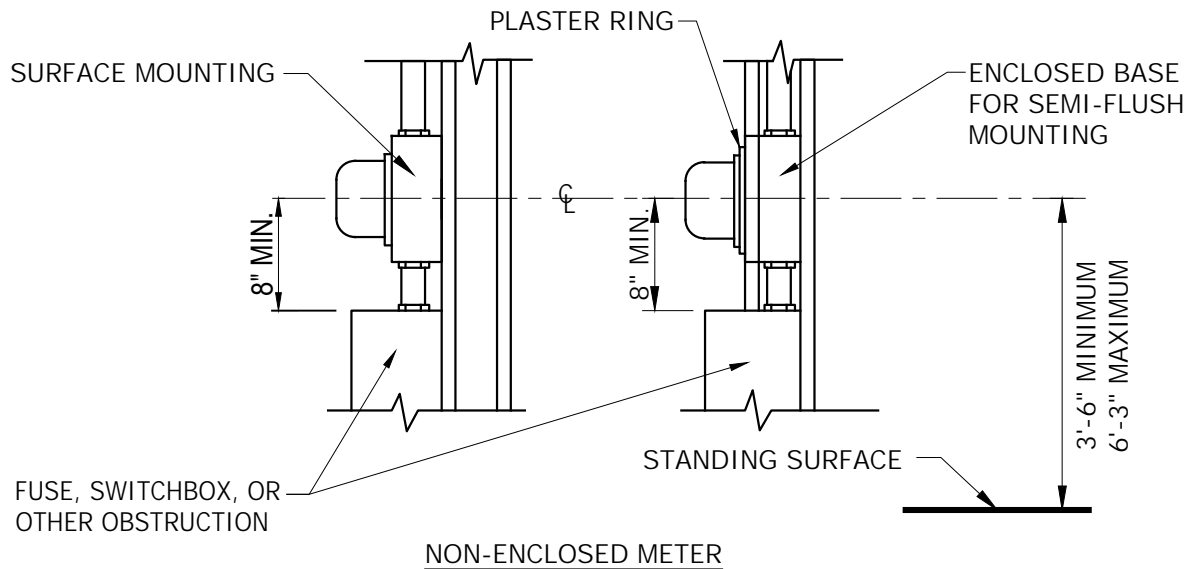

NON-ENCLOSED METER

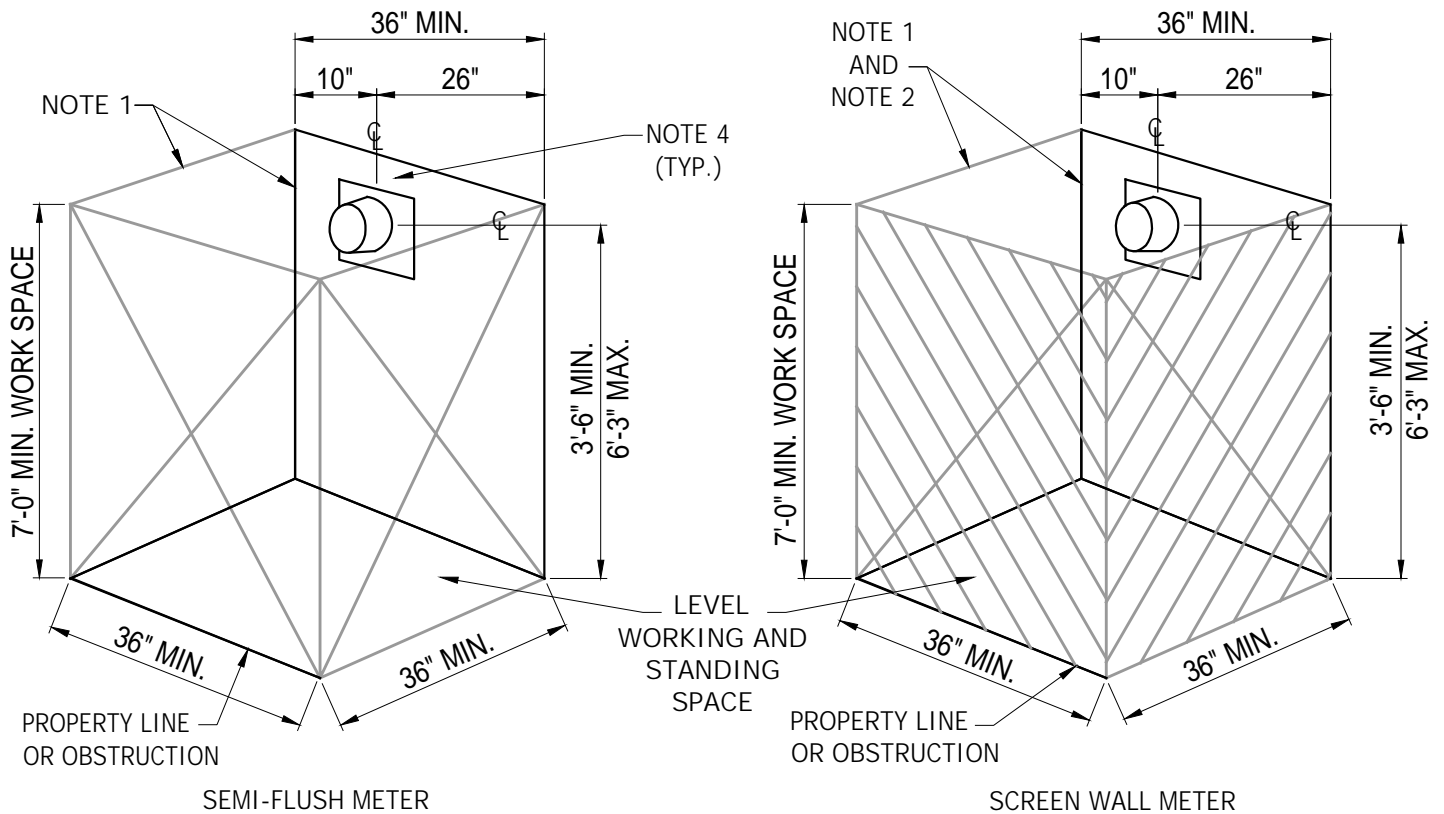

NOTES:

1. NEAREST SIDE WALL OR OTHER OBSTRUCTION.
2. ONE SIDE OF SCREEN WALL TO REMAIN OPEN.
3. SR-405, PAGE 5, NOTE 11.
4. NINE (9) INCH MINIMUM TO ANY OBSTRUCTION ABOVE METER.

 Tucson Electric Power	 SANTA CRUZ COUNTY	INITIATED BY	SC	REVISION NO.	8	SR-405 Pg. 10 of 10
		ESR COMM.	5-78	ESR COMM.	8-20	
				EFFECTIVE DATE	8-20	

USE: Residential and Small Commercial 100A, 3 Wire, Overhead Service or 30A Maximum, 2 Wire Overhead or Underground Services.

RESIDENTIAL, SMALL & PERMANENTLY UNOCCUPIED COMMERCIAL SERVICE ENTRANCE, 0-200A

Refer to SR-452 for the Complete Approved Metering and Service Equipment List.



RING TYPE SOCKET, CLASS 100
2W, 30A MAXIMUM SERVICES
FOR MAINTENANCE ONLY

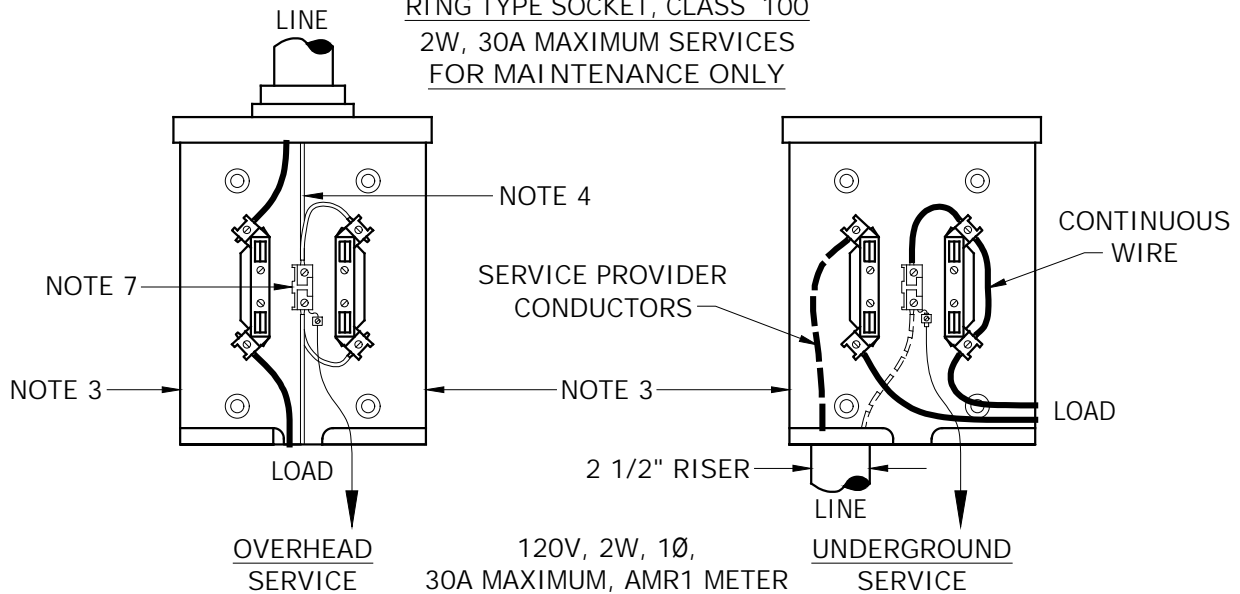

OVERHEAD SERVICE

120V, 2W, 1Ø,
30A MAXIMUM, AMR1 METER

UNDERGROUND SERVICE

RING TYPE SOCKET, CLASS 100
3W, 100A MAXIMUM,
OVERHEAD SERVICES

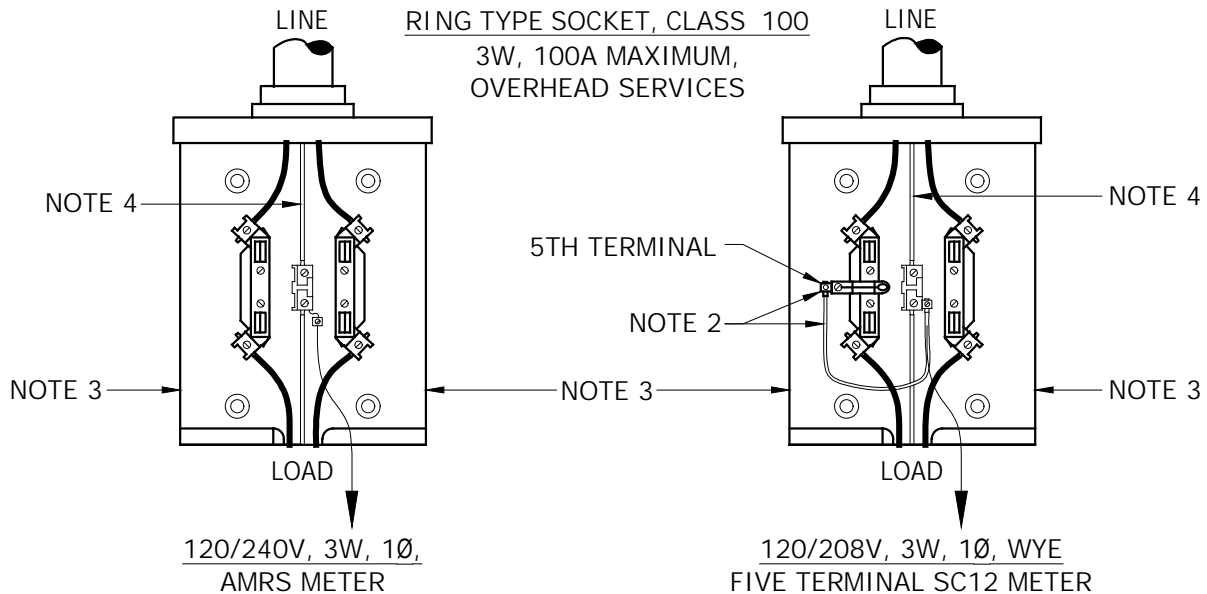

120/240V, 3W, 1Ø,
AMRS METER

120/208V, 3W, 1Ø, WYE
FIVE TERMINAL SC12 METER

NOTES:

1. Small commercial is defined as permanently unoccupied facilities, such as construction power, billboards, wells, etc.
2. Use #12 THHN or THW, solid copper wire, white in color, for neutral potential lead to connect 5th terminal, jaw installed in the 9 o'clock position, to neutral connection.
3. Optional load conductors exit. Plug any hole in socket not used for conductors.
4. If service is overhead, neutral conductor must be identified at the socket and weatherhead with white tape.
5. Refer to SR-405, Page 9, for approved socket interior.
6. Round sockets may be used on overhead installations.
7. Neutral connector shall be bonded to socket enclosure.
8. Refer to SR-408, Pages 2-3, for 200A maximum OH/UG commercial services where a bypass system is not required.



USE: Residential and
Permanently Unoccupied
Commercial Overhead,
1Ø, 200A Services.

RESIDENTIAL, SMALL & PERMANENTLY
UNOCCUPIED COMMERCIAL
SERVICE ENTRANCE, 0-200A

Refer to SR-452 for the Complete
Approved Metering and Service
Equipment List.



RING TYPE SOCKET, CLASS 200

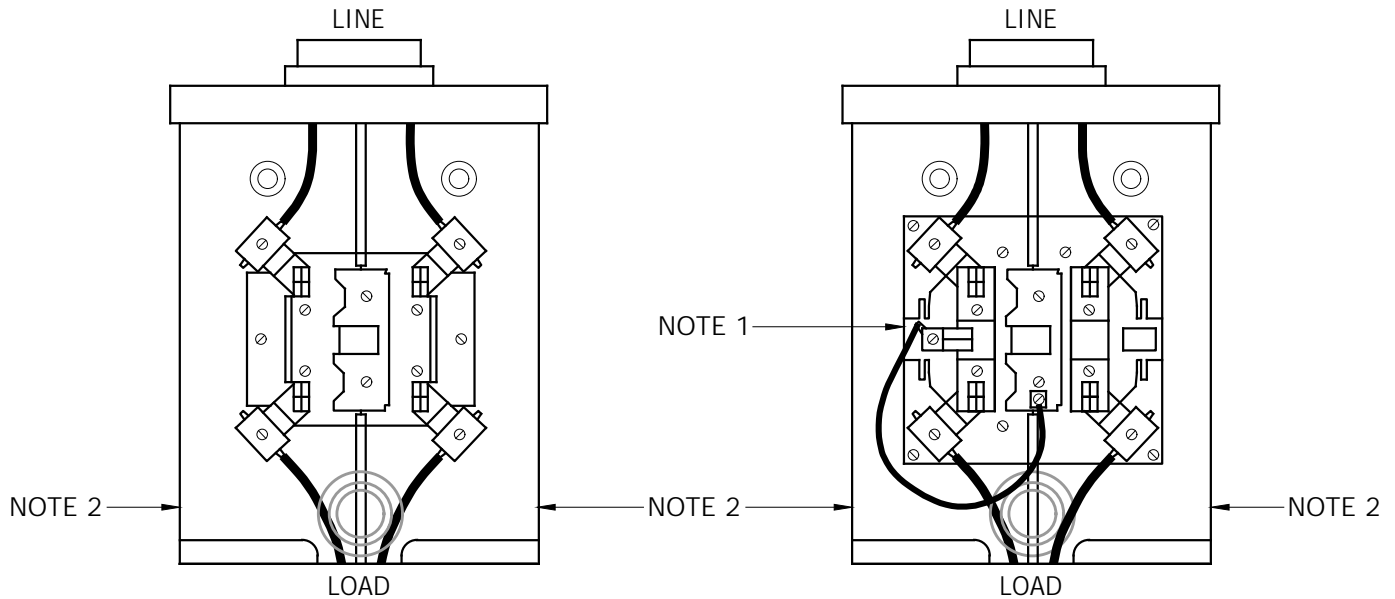

FIGURE 1
120/240V, 3W, 1Ø

FIGURE 2
120/208V, 1Ø, WYE



NOTES:

1. For Figure 2, install 5th terminal, jaw in the 9 o'clock position and connect to neutral connection with #12 THHN or THW, solid copper wire, white in color.
2. Optional load conductors exit. Plug any hole in socket not used for conductors.
3. Refer to SR-405, Page 9, for approved socket interior.
4. Neutral conductor must be identified at the socket and weatherhead with white tape.
5. Permanently unoccupied commercial installations defined as water wells, billboards, irrigation systems, etc. This installation for unoccupied services does not have bypass capability.
6. Neutral connector shall be bonded to socket enclosure.

USE: Residential & Permanently Unoccupied Commercial Underground, 0-200A, 3 Wire, 1Ø, Services.

RESIDENTIAL, SMALL & PERMANENTLY UNOCCUPIED COMMERCIAL SERVICE ENTRANCE, 0-200A

Refer to SR-452 for the Complete Approved Metering and Service Equipment List.



RING TYPE SOCKET, CLASS 200

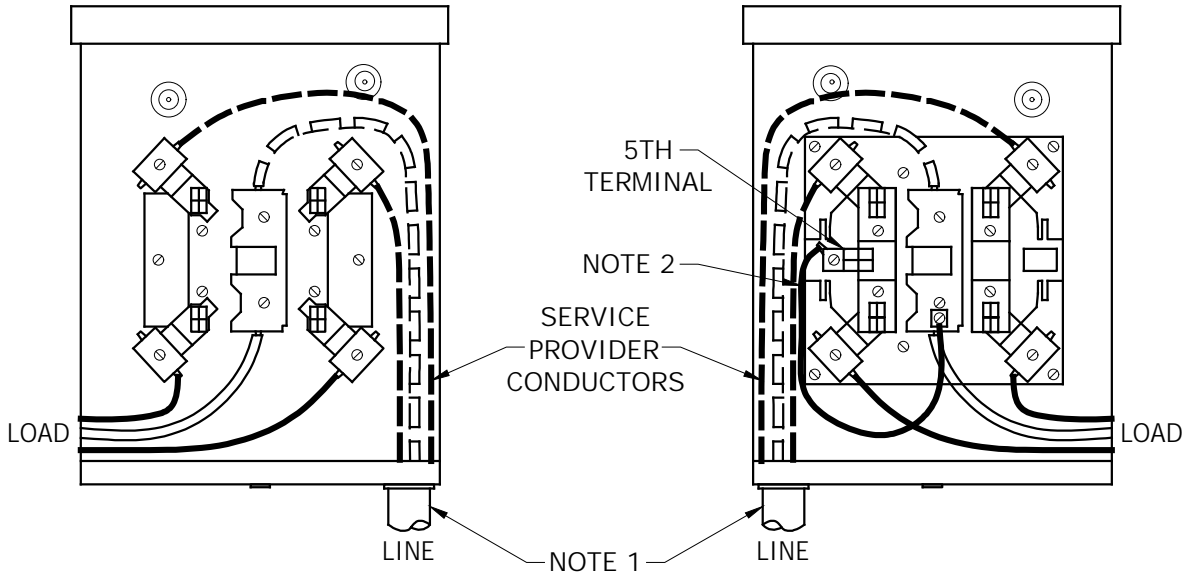

FIGURE 1
120/240V, 3W, 1Ø

FIGURE 2
120/208V, 1Ø, WYE



NOTES:

1. For underground service the 2 1/2" conduit riser must enter socket on the side opposite from that of the load conductors exit.
2. For Figure 2, install 5th terminal, jaw in the 9 o'clock position and connect to neutral connection with #12 THHN or THW, solid copper wire, white in color.
3. Lay-in grounded neutral connector must be suitable to terminate service neutral conductor in socket.
4. Line connectors must accommodate up to 250 kcmil aluminum stranded conductor.
5. Neutral connector shall be bonded to socket enclosure.
6. Minimum dimensions: 11" wide, 14" high, 4 1/2" deep.
7. Refer to SR-405, Page 9, for approved socket interior.
8. Permanently unoccupied commercial installations defined as water wells, billboards, irrigation systems, etc.
9. Neutral conductor must be identified at the socket and switch with white tape.

		INITIATED BY	SC	REVISION NO.	12	SR-408 Pg. 3 of 6
		ESR COMM.	8-77	ESR COMM.	5-19	
				EFFECTIVE DATE	5-19	

USE: Single Family Residential
120/240V, 3 wire, 1Ø

RESIDENTIAL, SMALL & PERMANENTLY
UNOCCUPIED COMMERCIAL
SERVICE ENTRANCE, 0-200A



EUSERC No. 301

Refer to SR-452 for the
Complete Approved Metering
and Service Equipment List.

UNDERGROUND COMBINATION METER
AND DISTRIBUTION

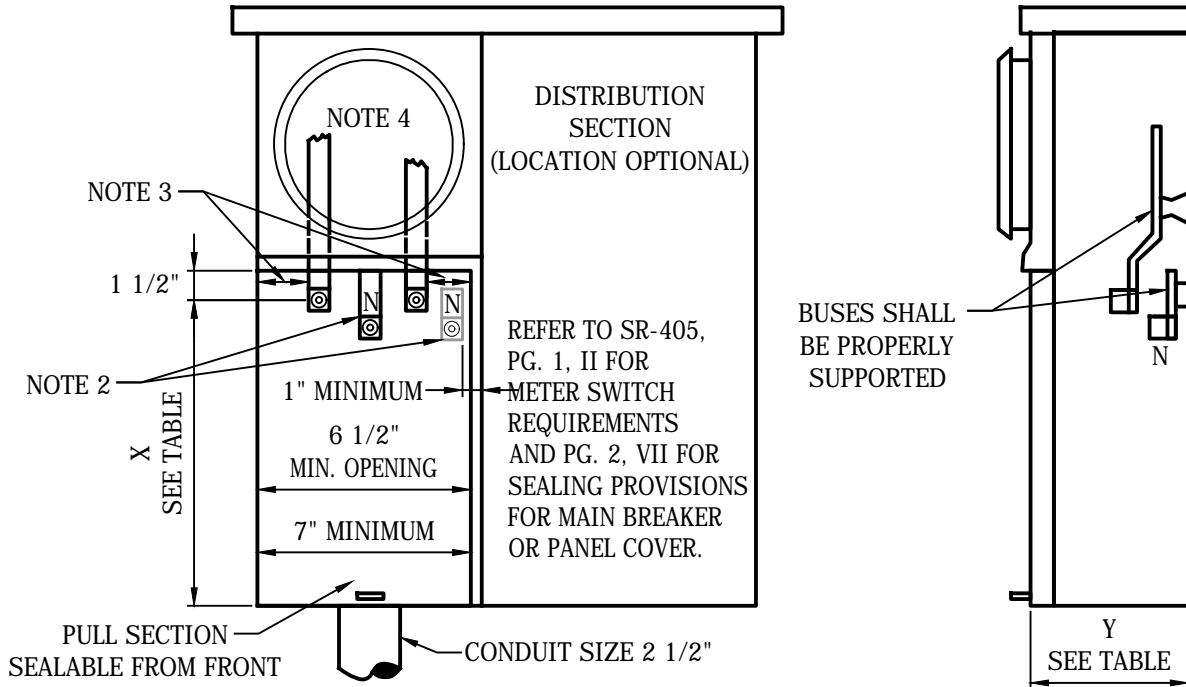

MAXIMUM AMPACITY	"X" MINIMUM DIMENSION		"Y" MINIMUM DIMENSION	CONNECTOR RANGE
	BARREL-TYPE LUGS	LAY-IN LUGS		
125	8"	6"	4"	#6-1/0 AWG
225	11"	8 1/2"	5-1/2"	1/0 AWG- 250 kcmil

NOTES:

1. Terminals for service conductors shall be aluminum bodied lugs.
2. Neutral terminal shall be a minimum dimension from the bottom of the enclosure of 6" (lay-in lugs 5") for the 125A device and 8-1/2" (lay-in lugs 6 1/2") for the 200 A device. Neutral bus shall be bonded to enclosure.
3. A minimum radial clearance of 1 1/2 inches, shall be provided between hot bus terminals and ground or neutral surfaces.
4. Socket interior must conform to SR-405, Pg. 9.
5. This equipment may be constructed for overhead (OH), underground (UG), or for combination OH/UG service applications. When built as an OH/UG device, a yellow caution label, 2" x 3" minimum, shall be installed below the termination in the pull section reading "Caution - Bus Energized at ALL times".
6. Pull section and breakers in distribution section must comply with sealing provisions specified in SR-405, Pg. 2.

USE: Underground Service
 0-200A, 120/240V,
 3 wire, 1Ø

RESIDENTIAL, SMALL & PERMANENTLY
 UNOCCUPIED COMMERCIAL
 SERVICE ENTRANCE, 0-200A



EUSERC No. 307

Refer to SR-452 for the
 Complete Approved Metering
 and Service Equipment List.

METER POST

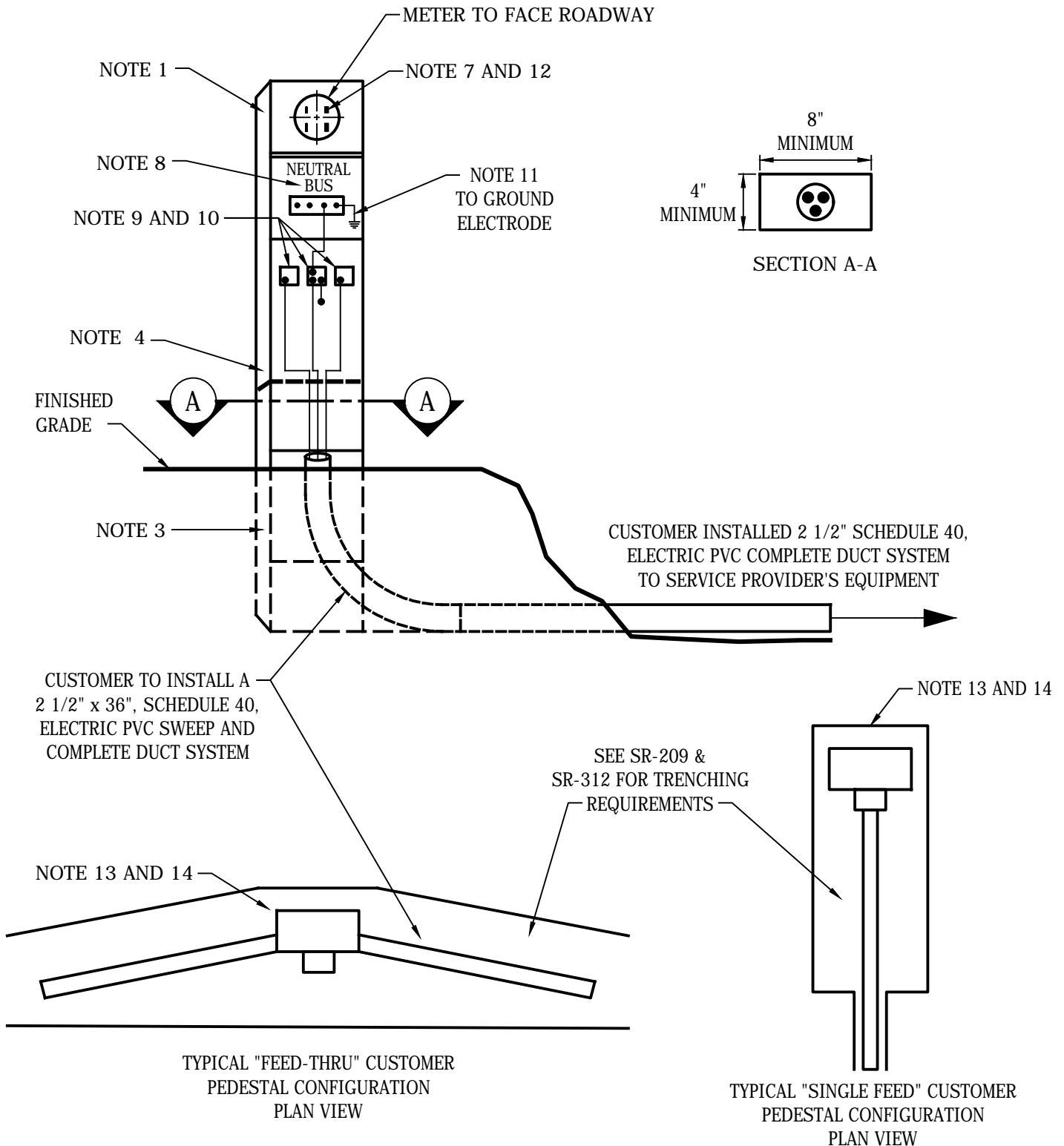

		INITIATED BY	SC	REVISION NO.	18	SR-408
		ESR COMM.	8-79	ESR COMM.	5-19	
				EFFECTIVE DATE	5-19	

USE: Underground Service
0-200A, 120/240V,
3 wire, 1Ø

RESIDENTIAL, SMALL & PERMANENTLY
UNOCCUPIED COMMERCIAL
SERVICE ENTRANCE, 0-200A

EUSERC No. 307



METER POST

GENERAL CONSTRUCTION:

1. This type post shall have a minimum rating of 100 amperes. Construction, material, and corrosive-resistant finish shall be approved by a Nationally-recognized test laboratory.
2. The post shall have a minimum cross sectional dimension of 4" x 8" ID, minimum access opening width of 7 1/2 inches.
3. The minimum depth of the post in the ground shall be 24 inches, with openings at the base sufficient to permit 2 1/2" x 36", 90° elbow(s) to sweep into the post from the front (meter side). A fixed panel shall extend 2 inches minimum to 6 inches maximum above grade, and 18 inches minimum below grade.
4. Adequate ventilation shall be provided to inhibit the condensation of moisture within the enclosure such as required by UL-231.
5. The minimum meter height shall be 48 inches above grade line when the meter is exposed or 36 inches when enclosed with a shatter proof window through which to read the meter.
6. The service cable pull and terminating section shall be accessible from either the front or rear of the post by removing an 8 inch minimum width sealable panel (or panels). All removable panels must be equipped with sealable fasteners. The removable panel (or panels) shall extend from the top of the fixed panel (see Note 3) and when removed, allow full access to the terminating lugs. The service cable pull and termination section space shall be restricted to serving agency use only.
7. If the meter is enclosed, the enclosing cover shall be hinged and self-supporting, equipped with a shatter proof reading window and be removable for meter testing or inspections.
8. The service main disconnect and power outlet section shall have barriers installed to prevent access to the service cable pull and termination section and to un-metered conductors which connect to the socket.



SERVICE TERMINATING FACILITIES:

9. The service terminating lugs shall be twin No. 2 to 350 kcmil aluminum bodied pressure type lug height, measured to the bottom of terminating lug from the grade line, shall be 18 inches minimum and 48 inches maximum. The space between termination lugs, from lugs to sides of post, from lugs to any grounded surface, or from lugs to panel above shall be 1-1/2 inches minimum. Rigid insulating barriers are required and shall project 1/4 inch minimum beyond any energized parts when this space is reduced. Terminating lugs may be positioned either in line or staggered, and access shall be unobstructed when all service conductors are in place.
10. The neutral terminating lug, shall be bonded to the enclosure.

GROUNDING FACILITIES:

11. An accessible equipment grounding lug shall be provided in accordance with UL-414. The service disconnect switch shall be effectively grounded per local governmental code or national electrical code requirements in the absence of local codes.

METERING FACILITIES:



12. The meter socket base shall be fabricated with components tested by a EUSERC recognized test laboratory and shall be provided with a sealing ring. See SR-405, pg. 9, for additional requirements. The meter socket shall be mounted on support and attached to meter panel. The socket shall be factory-wired with the conductors located in a separate or barriered raceway from the service terminating lugs to the meter socket. The conductors which extend to the meter socket shall be connected at the service terminating lugs independently of the connection for the service lateral conductors. Dual socket meter posts are acceptable.

INSTALLATION:

13. The customer is to obtain a service installation date from the company and be responsible for having the meter post(s), elbow(s) and complete conduit system installed at each location per the drawing on Page 5. The meter post to be in a upright and plumb position with backfill and tamping to support the meter post. These installations will all be completed prior to Service Provider's arrival.
14. Prior to service installation, the customer is to backfill and compact the service trench. After the backfill has been completed the customer will be responsible for any cost incurred by Service Provider, should a relocation of the meter post be requested by the customer. Relocation work by Service Provider, anytime after the initial terminations have been made will be billable to the customer.
15. An approved disconnecting means will be required prior to service being turned on for an individual applicant.

ENCLOSURE ATTACHMENT:

16. For authorization to attach telephone and cable T.V. terminating facilities to the post, contact Design Services.

 Tucson Electric Power		INITIATED BY	SC	REVISION NO.	16	SR-408 Pg. 6 of 6
		ESR COMM.	8-79	ESR COMM.	5-19	
				EFFECTIVE DATE	5-19	

USE: SERVICE TO UNOCCUPIED FACILITIES WHERE METERING INSTALLATION IS EXPOSED TO POTENTIAL VANDALISM (TRAFFIC SIGNALS, WIRELESS SITES, ETC.)

SERVICE PEDESTAL FOR USE IN COMMON PUBLIC AREA & RIGHT-OF-WAY, 0-200A, 0-600V



EUSERC DWG. NO. 308

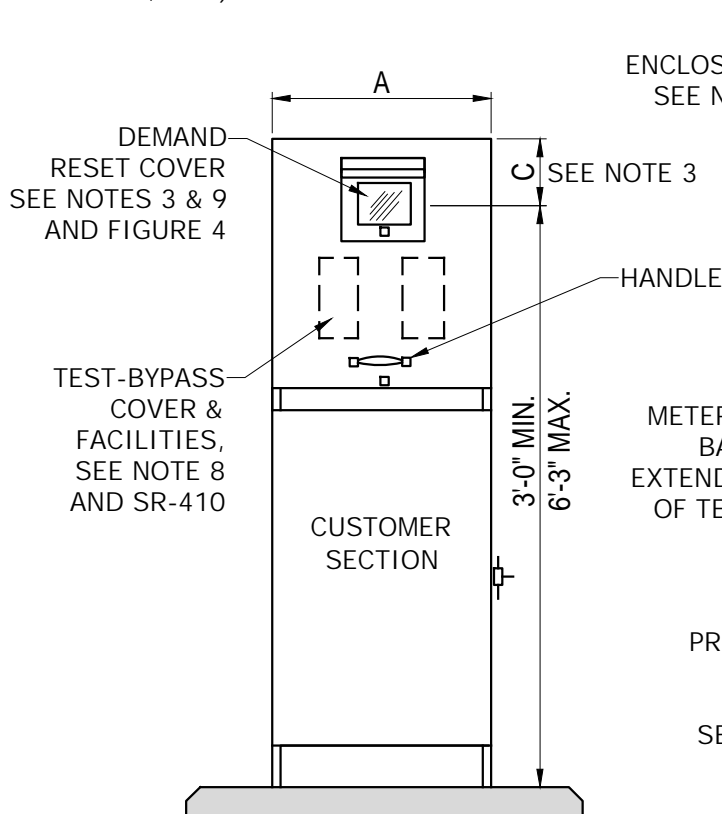

FIGURE 1
FRONT VIEW

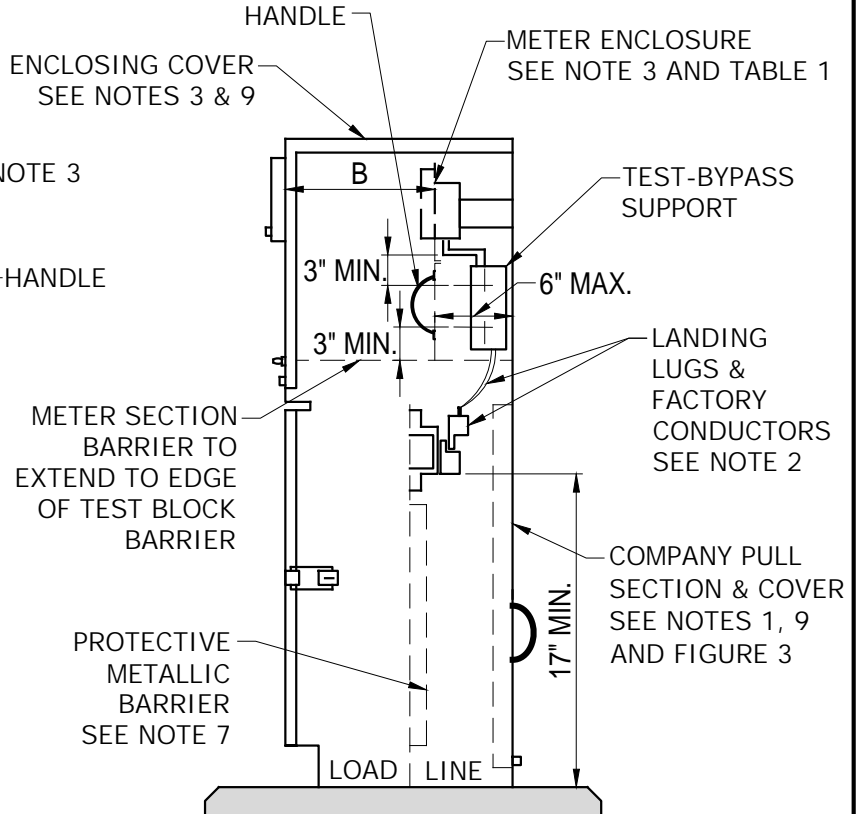

FIGURE 2
SIDE VIEW

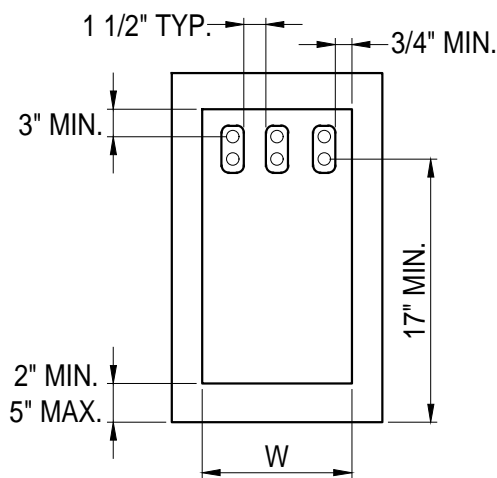

FIGURE 3
COMPANY PULL SECTION

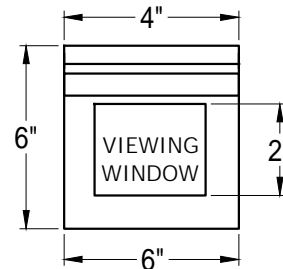

FIGURE 4
DEMAND RESET COVER
NOTE: ALL DIMENSIONS ARE MINIMUM

SERVICE TYPE	W	A	B	C
SINGLE-PHASE	10 1/2	20	11	9
THREE-PHASE	12 1/2			

USE: SERVICE TO UNOCCUPIED FACILITIES WHERE METERING INSTALLATION IS EXPOSED TO POTENTIAL VANDALISM (TRAFFIC SIGNALS, WIRELESS SITES, ETC.)

SERVICE PEDESTAL FOR USE IN COMMON PUBLIC AREA & RIGHT-OF-WAY, 0-200A, 0-600V



EUSERC DWG. NO. 308

NOTES:

1. Company pull section shall be dimensioned as shown in TABLE 1. These dimensions are the minimum access openings allowed for these types of termination sections. The bottom of pull section shall accept a 3 inch minimum conduit.
2. Service conductors are to be terminated on landing lugs. The service terminating lugs shall be #6 through 350 kcmil pressure-type, CU-AL listed. Insulated cable or buss shall be installed between the landing lugs and the test-bypass facilities.
3. The meter shall be enclosed. The enclosing cover (top and front) shall be hinged or the top may be fixed in place if the front is removable. When the top is fixed in place, dimension "C" from TABLE 1 must be maintained. When the top and front are hinged, dimension "C" does not apply. If the sides are removable, dimension "A" does not apply. A hinged enclosing cover shall not exceed 25 pounds. A demand reset cover constructed of steel shall be provided. This cover shall have a hinged polycarbonate viewing window and comply with the minimum dimensions as shown in FIGURE 4.
4. Ringless sockets are not acceptable.
5. Internal equipment shall be secured in place without screws or nuts on the outer surface of the enclosure that may be loosened from the outside.
6. For structural mounting and support of the pedestal consult the Agency Having Jurisdiction (AHJ).
7. A protective metallic barrier (16 gauge minimum) shall be installed between the utility wireway and the customer distribution section. There shall be a 1/4 inch minimum clearance between the customer section and protective barrier to prevent screws and bolts from protruding into the termination section.
8. Test-bypass blocks with rigid insulation barriers shall be furnished, installed and wired or bussed to the meter socket by the manufacturer. Connection sequence is LINE-LOAD from left to right. Each line and load position shall be clearly identified by 3/4 inch minimum block letter labeling. Test-bypass cover panels shall be sealable and fitted with a lifting handle. All panels exceeding 16 inches in width shall require two lifting handles.
9. All utility compartments (meter cover, demand reset cover, and pull section) shall be sealable and pad-lockable.
10. See SR-452 for the approved service pedestal list.
11. The customer is to provide and install a 2 1/2 inch total conduit system per SR-205, SR-207, SR-209, SR-310, SR-312, and SR-405. Design Services will determine the location where the new service is to be installed.
12. At no time shall an alternate power source exist in parallel operation with The Company's distribution system. Any mechanical or automatic means of source transfer or throw-over must operate in open transition (break-before-make).
13. Voltages available for use are 120/240V or 120/208V for single-phase; and 240/480V or 277/480V for three-phase installations.

		INITIATED BY	SC	REVISION NO.	6	SR-409
		ESR COMM.	7-93	ESR COMM.	11-21	
				EFFECTIVE DATE	11-21	
						Pg. 2 of 2

USE: SINGLE-PHASE,
120/240V, 100A &
200A, 4 TERMINAL

SAFETY SOCKET BOX, TEST-BYPASS BLOCK AND SWITCHBOARDS



EUSERC DWG.
NO. 304 & 305



REFER TO SR-452 FOR THE
COMPLETE APPROVED METERING
AND SERVICE EQUIPMENT LIST

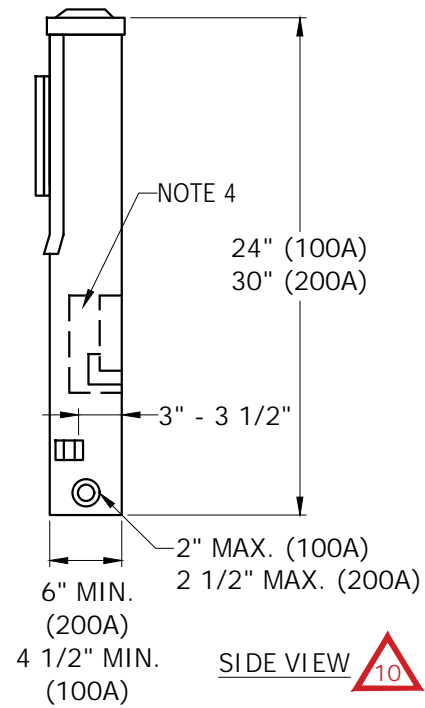
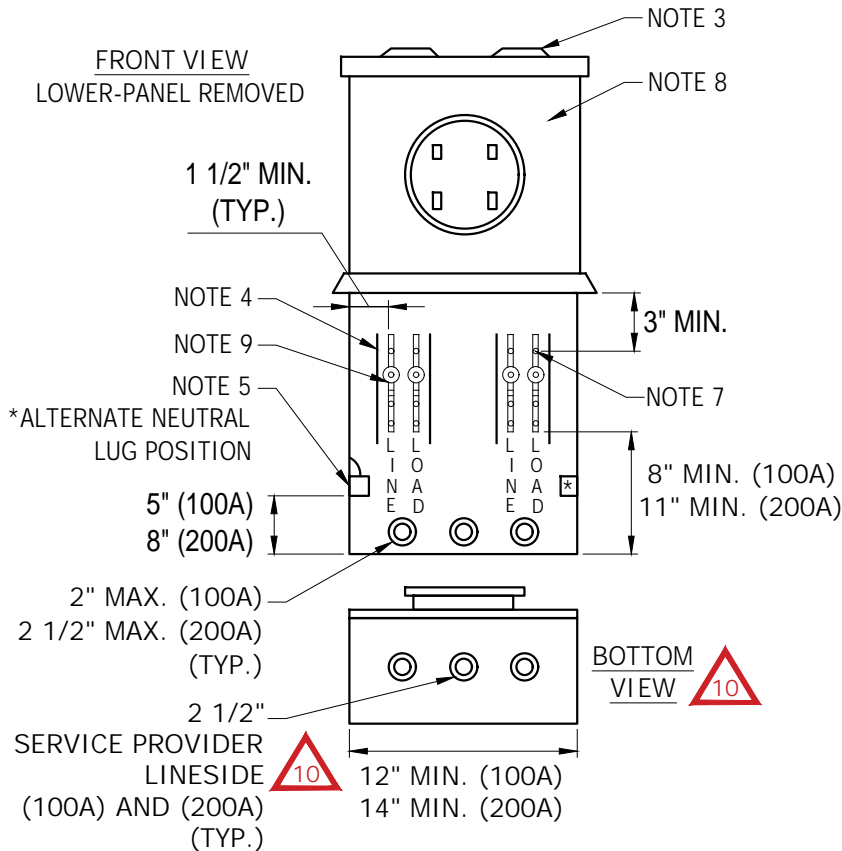

NOTES:

- THIS DEVICE MAY BE USED FOR TERMINATING/PULLING AND METER SOCKET BOX FOR AN UNDERGROUND SERVICE.
- ALUMINUM BODIED TERMINALS FOR NO. 6 THROUGH NO. 1/0AWG WIRE (100A) OR 1/0AWG THROUGH 250KCMIL (200A).
- UNUSED HUBS CAPPED OFF WITH A RAINPROOF ACCESS PLATE(S) THAT IS SECURED INTERNALLY UTILIZING A CARRIAGE BOLT AND A WINGNUT BAR THAT SPANS BEYOND THE OPENING, SEE SR-405.
- RIGID INSULATING BARRIERS.
- INSULATED BONDABLE VERTICAL LAY-IN, DOUBLE NEUTRAL LUG WITH NO. 1/0 (100A), NO. 250 KCMIL (200A), AWG WIRE CAPACITY MOUNTED ON EITHER SIDEWALL. NEUTRAL LUG SHALL BE BONDED TO ENCLOSURE.
- TEST-BYPASS BLOCKS SHALL BE BUSSED OR WIRED TO SOCKET JAWS OR TERMINALS.
- UPPER TEST CONNECTOR STUDS.
- ALL SECTION PANELS SHALL BE INDEPENDENTLY REMOVABLE. UPPER PANEL SHALL BE NON-REMOVABLE WHEN METER IS IN PLACE. METER SOCKET SHALL BE MOUNTED ON SUPPORT AND ATTACHED TO UPPER PANEL. LOWER PANEL SHALL BE SEALABLE AND PERMANENTLY LABELED, "DO NOT BREAK SEALS, NO FUSES INSIDE".
- TEST-BYPASS BLOCK DETAIL. SEE SR-410, PAGE 3.
- FOR SINGLE-PHASE, 3 WIRE SERVICE, PROVIDE TWO TEST-BYPASS BLOCKS MOUNTED IN THE OUTER POSITIONS AND A FOUR JAW SOCKET (FORM 2 METER).
- PERMANENT LABEL ON INSIDE BACK OF ENCLOSURE IS 3/4" MINIMUM HIGH BLOCK LETTERS.
- FOR SWITCHBOARD APPLICATION, REFER TO SR-410, PAGE 6.
- THIS SOCKET IS REQUIRED FOR MULTI-METERED COMMERCIAL APPLICATIONS, SR-418.
- REFER TO SR-408, PAGES 1, 3 AND 4 FOR SOCKET REQUIREMENTS FOR PERMANENTLY UNOCCUPIED COMMERCIAL INSTALLATIONS SUCH AS WATER WELLS, BILLBOARDS, IRRIGATION SYSTEMS, ETC., WHERE A BY-PASS SYSTEM IS NOT NEEDED.
- MINIMUM WIDTH OF ACCESS OPENING SHALL BE 11 1/2" FOR 100A, 13 1/2" FOR 200A SOCKET.
- WHEN INSTALLING A SAFETY SOCKET FOR METERING OF STREET LIGHT INSTALLATIONS OR IN PARKS, SCHOOL YARDS AND OTHER AREAS SUBJECT TO VANDALISM, INSTALL A PROTECTIVE COVER (METER DEVICES/BROOKS CAT. #4042) ON THE METER BASE.

USE: SINGLE-PHASE,
 120/208V, 120/240V,
 100A & 200A, 5 TERMINAL

SAFETY SOCKET BOX, TEST-BYPASS BLOCK AND SWITCHBOARDS

EUSERC DWG.
NO. 304 & 305

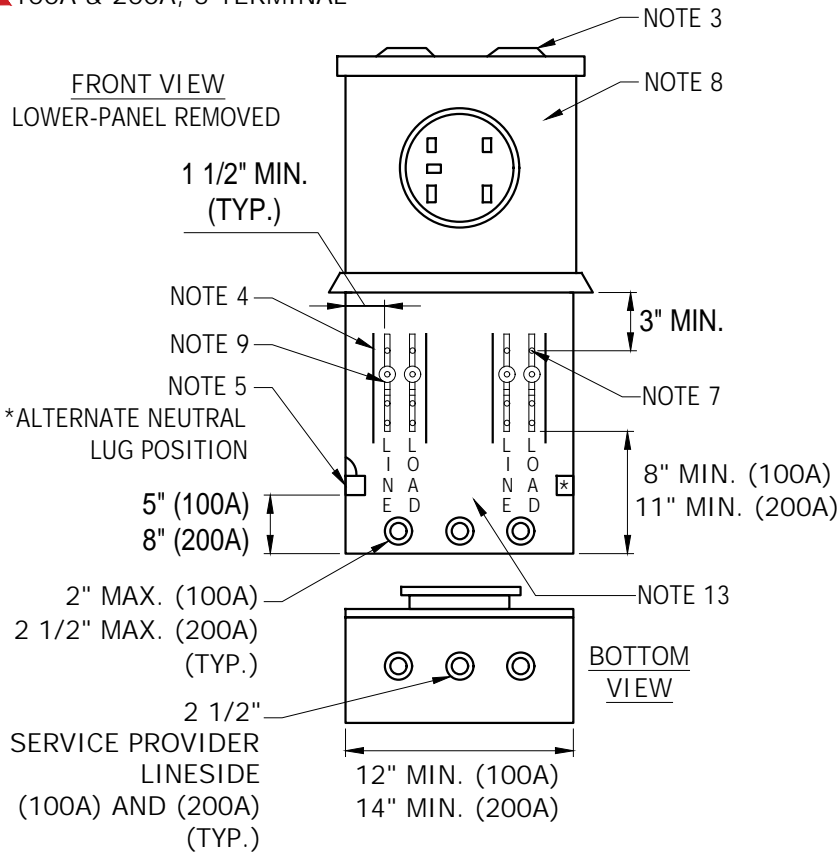

REFER TO SR-452 FOR THE COMPLETE APPROVED METERING AND SERVICE EQUIPMENT LIST

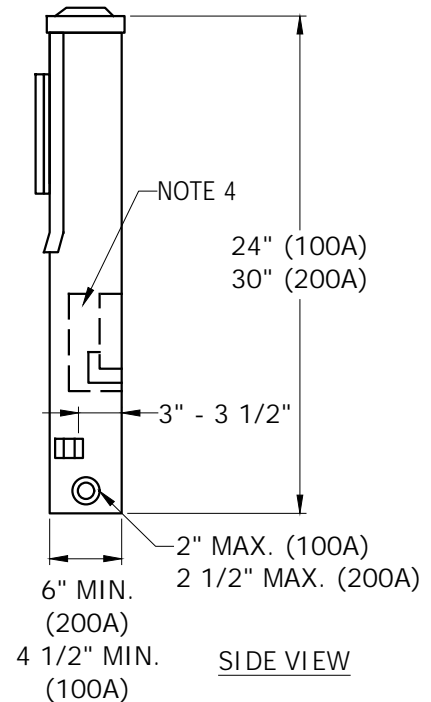

NOTES:

1. THIS DEVICE MAY BE USED FOR TERMINATING/PULLING AND METER SOCKET BOX FOR AN UNDERGROUND SERVICE.
2. ALUMINUM BODIED TERMINALS FOR NO. 6 THROUGH NO. 1/0AWG WIRE (100A) OR 1/0AWG THROUGH 250 KCMIL (200A).
3. UNUSED HUBS CAPPED OFF WITH A RAINPROOF ACCESS PLATE(S) THAT IS SECURED INTERNALLY UTILIZING A CARRIAGE BOLT AND A WINGNUT BAR THAT SPANS BEYOND THE OPENING, SEE SR-405.
4. RIGID INSULATING BARRIERS.
5. INSULATED BONDABLE VERTICAL LAY-IN, DOUBLE NEUTRAL LUG WITH NO. 1/0 (100 A), NO. 250 KCMIL (200 A), AWG WIRE CAPACITY MOUNTED ON EITHER SIDEWALL. NEUTRAL LUG SHALL BE BONDED TO ENCLOSURE.
6. TEST-BYPASS BLOCKS SHALL BE BUSSED OR WIRED TO SOCKET JAWS OR TERMINALS.
7. UPPER TEST CONNECTOR STUDS.
8. ALL SECTION PANELS SHALL BE INDEPENDENTLY REMOVABLE. UPPER PANEL SHALL BE NON-REMOVABLE WHEN METER IS IN PLACE. METER SOCKET SHALL BE MOUNTED ON SUPPORT AND ATTACHED TO UPPER PANEL. LOWER PANEL SHALL BE SEALABLE AND PERMANENTLY LABELED, "DO NOT BREAK SEALS, NO FUSES INSIDE".
9. TEST-BYPASS BLOCK DETAIL. SEE SR-410, PAGE 3.
10. FOR SINGLE-PHASE, 3 WIRE, 208V, FORM 12 METER, PROVIDE TWO TEST-BYPASS BLOCKS MOUNTED IN THE OUTER POSITION AND A FIVE JAW SOCKET. CONNECT 5TH JAW OF METER SOCKET TO BODY OF NEUTRAL LUG WITH #12 MIN. COPPER WIRE, WHITE IN COLOR. THE 5TH JAW OF THE METER SOCKET IS TO BE SECURELY ATTACHED TO THE METER SOCKET.
11. PERMANENT LABEL ON INSIDE BACK OF ENCLOSURE IS 3/4" MINIMUM HIGH BLOCK LETTERS.
12. FOR SWITCHBOARD APPLICATION, REFER TO SR-410, PAGE 6.
13. THIS SOCKET IS REQUIRED FOR MULTI-METERED COMMERCIAL INSTALLATIONS, SR-418.
14. REFER TO SR-408, PAGE 1, 3 & 4 FOR SOCKET REQUIREMENTS FOR PERMANENTLY UNOCCUPIED COMMERCIAL INSTALLATIONS SUCH AS WATER WELLS, BILLBOARDS, IRRIGATION SYSTEMS, ETC., WHERE A BYPASS SYSTEM IS NOT NEEDED.
15. MINIMUM WIDTH OF ACCESS OPENING SHALL BE 11 1/2" FOR 100A, 13 1/2" FOR 200A SOCKET.
16. WHEN INSTALLING A SAFETY SOCKET FOR METERING OF STREET LIGHT INSTALLATIONS OR IN PARKS, SCHOOL YARDS AND OTHER AREAS SUBJECT TO VANDALISM, INSTALL A PROTECTIVE COVER (METER DEVICES/BROOKS CAT. #4042) ON THE METER BASE.

USE: THREE-PHASE,
120/208V, 120/240V,
277V/480V, 240/480V,
100A & 200A, 7 TERMINAL

SAFETY SOCKET BOX, TEST-BYPASS BLOCK AND SWITCHBOARDS



EUSERC DWG.
NO. 304 & 305



REFER TO SR-452 FOR THE
COMPLETE APPROVED METERING
AND SERVICE EQUIPMENT LIST

FRONT VIEW
LOWER-PANEL REMOVED

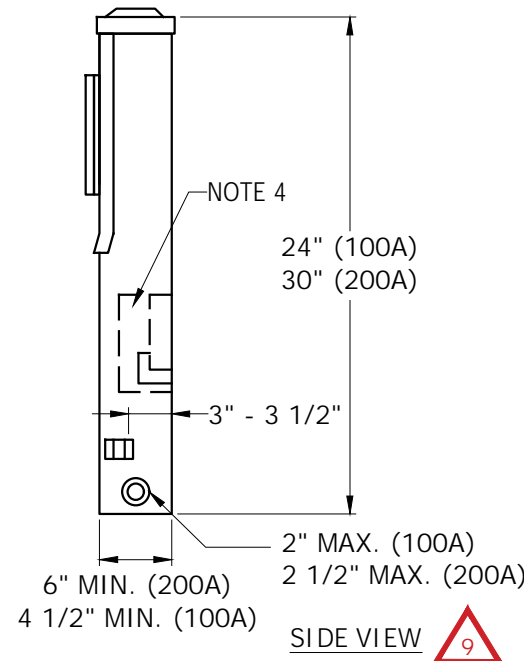
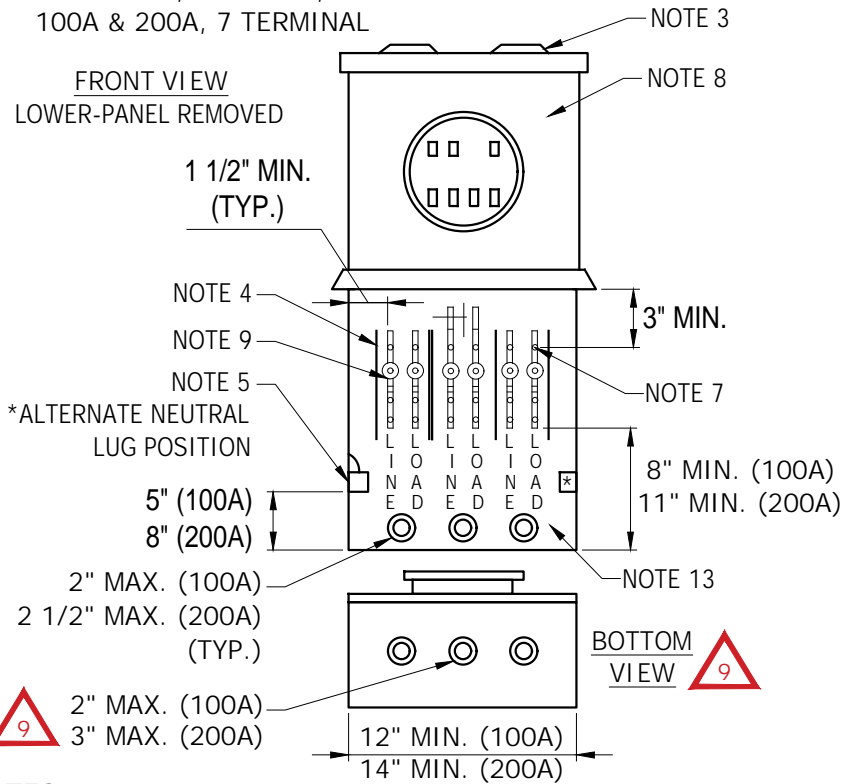

NOTES:

1. THIS DEVICE MAY BE USED FOR TERMINATING/PULLING AND METER SOCKET BOX FOR AN UNDERGROUND SERVICE.
2. ALUMINUM BODIED TERMINALS FOR NO. 6 THROUGH NO. 1/0 AWG WIRE (100A) OR 1/0 AWG THROUGH 250 KCMIL (200A).
3. UNUSED HUBS CAPPED OFF WITH A RAINPROOF ACCESS PLATE(S) THAT IS SECURED INTERNALLY UTILIZING A CARRIAGE BOLT AND A WINGNUT BAR THAT SPANS BEYOND THE OPENING, SEE SR-405.
4. RIGID INSULATING BARRIERS.
5. INSULATED BONDABLE VERTICAL LAY-IN, DOUBLE NEUTRAL LUG WITH NO. 1/0 (100A), NO. 250 KCMIL (200A), AWG WIRE CAPACITY MOUNTED ON EITHER SIDEWALL. NEUTRAL LUG SHALL BE BONDED TO ENCLOSURE.
6. TEST-BYPASS BLOCKS SHALL BE BUSSED OR WIRED TO SOCKET JAWS OR TERMINALS.
7. UPPER TEST CONNECTOR STUDS.
8. ALL SECTION PANELS SHALL BE INDEPENDENTLY REMOVABLE. UPPER PANEL SHALL BE NON-REMOVABLE WHEN METER IS IN PLACE. METER SOCKET SHALL BE MOUNTED ON SUPPORT AND ATTACHED TO UPPER PANEL. LOWER PANEL SHALL BE SEALABLE AND PERMANENTLY LABELED, "DO NOT BREAK SEALS, NO FUSES INSIDE".
9. TEST-BYPASS BLOCK DETAIL. SEE SR-410, PAGE 3.
10. FOR THREE-PHASE, 4 WIRE, CONNECT 7TH JAW TO BODY OF NEUTRAL LUG WITH #12 AWG COPPER WIRE WHITE IN COLOR (SEVEN JAW SOCKET).
11. FOR THREE-PHASE, 240/120V, 4 WIRE DELTA, IDENTIFY RIGHT HAND SIDE OF THE TEST-BYPASS BLOCK, LINE AND LOAD SIDE (2 POLES) AS THE POWER LEG (SEVEN JAW SOCKET).
12. PERMANENT LABEL ON INSIDE BACK OF ENCLOSURE IS 3/4" MINIMUM HIGH BLOCK LETTERS.
13. FOR SWITCHBOARD APPLICATION, REFER TO SR-410, PAGE 6.
14. THIS SOCKET IS REQUIRED FOR MULTI-METERED COMMERCIAL INSTALLATIONS, SEE SR-418.
15. REFER TO SR-408, PAGES 1, 3 & 4 FOR SOCKET REQUIREMENTS FOR PERMANENTLY UNOCCUPIED COMMERCIAL INSTALLATIONS SUCH AS WATER WELLS, BILLBOARDS, IRRIGATION SYSTEMS, ETC., WHERE A BYPASS SYSTEM IS NOT NEEDED.
16. MINIMUM WIDTH OF ACCESS OPENING SHALL BE 11 1/2" FOR 100A, 13 1/2" FOR 200A SOCKET.
17. WHEN INSTALLING A SAFETY SOCKET FOR METERING OF STREET LIGHT INSTALLATIONS OR IN PARKS, SCHOOL YARDS AND OTHER AREAS SUBJECT TO VANDALISM, INSTALL A PROTECTIVE COVER (METER DEVICES/BROOKS CAT. #4042) ON THE METER BASE.
18. ALL METER SOCKETS AND SERVICES ARE TO IDENTIFIED WITH AN ADDRESS TAG AS PER SR-405, NOTE 5 AND 16.
19. ALL CONDUCTORS SHALL BE COLOR CODE IDENTIFIED AS PER SR-405, NOTE 16.

		INITIATED BY	MS	REVISION NO.	9	SR-410 Pg. 3 of 10
		ESR COMM.	10-89	ESR COMM.	9-20	
				EFFECTIVE DATE	9-20	

USE: TEST BYPASS,
DISCONNECT BLOCK
FOR SAFETY SOCKET,
100A AND 200A

SAFETY SOCKET BOX, TEST-BYPASS BLOCK
AND SWITCHBOARDS



EUSERC DWG.
NO. 311



TEST-BYPASS BLOCK
100A AND 200A

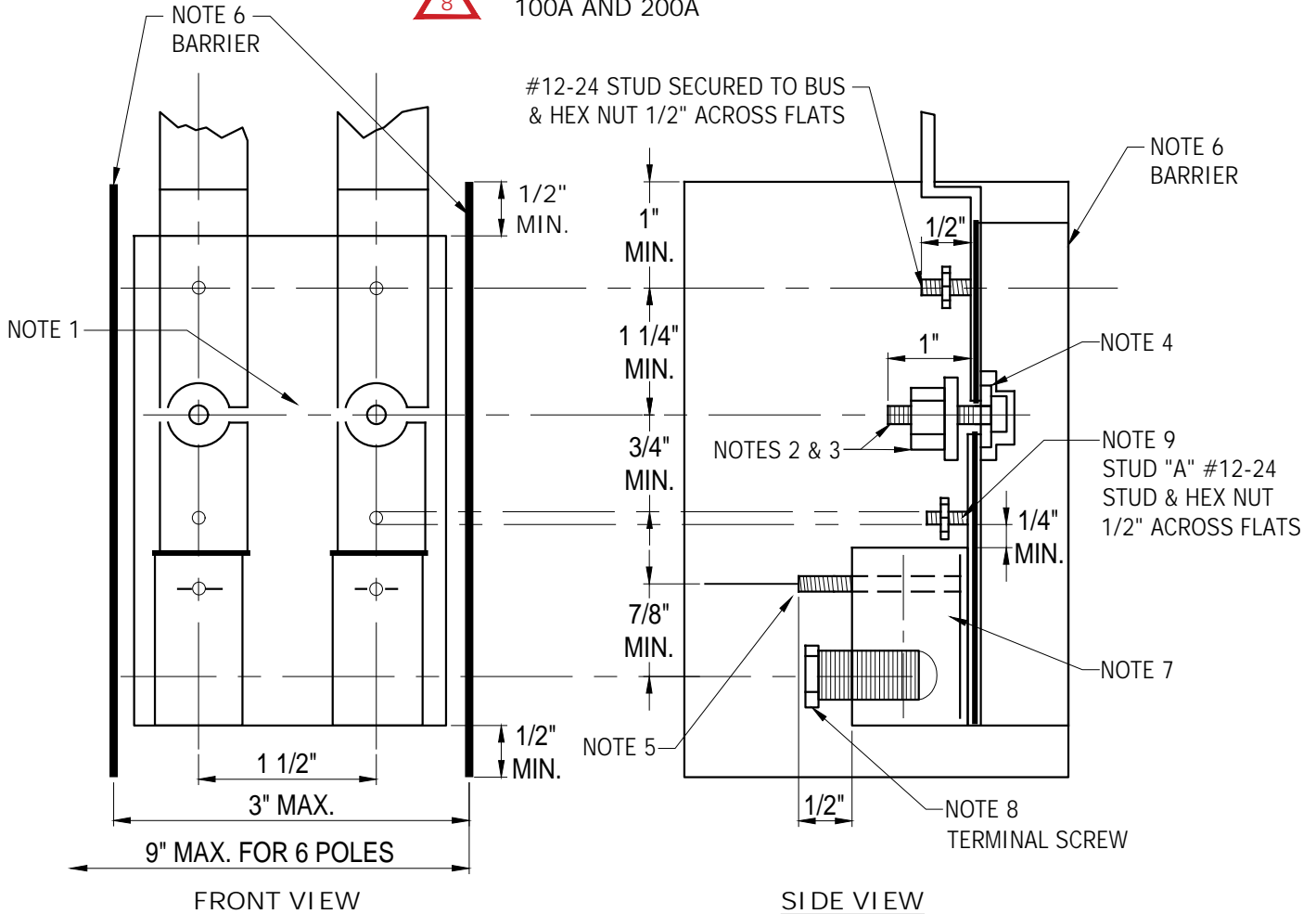

NOTES:

1. DISTANCE BETWEEN UPPER AND LOWER BUS SECTIONS SHALL NOT BE LESS THAN 1/4 INCH WHEN SHORTING NUT IS BACKED OFF.
2. CIRCUIT-CLOSING NUT SHALL BE A HEX NUT 5/8 INCH ACROSS FLATS WITH PLATED COPPER WASHER ATTACHED AND HAVE THREADS COUNTER-BORED AT BOTTOM TO FACILITATE RE-INSTALLATION. BOLT HEAD SHALL BE SECURED IN PLACE TO PREVENT TURNING AND BACKOUT.
3. THE CIRCUIT-CLOSING NUT AND BOLT ASSEMBLY SHALL MAINTAIN THE APPLIED CONTACT PRESSURE BETWEEN THE PLATED COPPER WASHER AND THE BUS MEMBERS OF THE TEST-BYPASS BLOCK.
4. INSULATING WASHER SHALL BE MADE FROM DIMENSIONALLY STABLE, NON-TRACKING MATERIAL AND SHALL PROVIDE A MINIMUM OF 1/8 INCH CREEP DISTANCE BETWEEN THE BOLT AND THE BUS SECTIONS. BUS SECTIONS SHALL BE PLATED.

USE: TEST BYPASS,
DISCONNECT BLOCK
FOR SAFETY SOCKET,
100A AND 200A

SAFETY SOCKET BOX, TEST-BYPASS BLOCK
AND SWITCHBOARDS





EUSERC DWG.
NO. 311



NOTES (CONTINUED):

5. WIRE STOPS SHALL EXTEND TO CENTER OF TERMINAL OPENING OR BEYOND. THE WIRE STOP STUDS SHALL NOT BE USED FOR THE PURPOSE OF MODIFY MOUNTING OF TERMINAL CONNECTORS.
6. RIGID INSULATING BARRIERS SHALL PROJECT AT LEAST 1/4 INCH BEYOND ANY ENERGIZED PARTS WHEN THE MAXIMUM WIRE SIZE IS INSTALLED.
7. TERMINALS SHALL BE ALUMINUM BODIED. FOR REQUIRED CONDUCTOR RANGE, SEE SR-410, PAGES 1 & 2. THE OPENING SHALL EXTEND THROUGH THE TERMINAL BODY AND, IF WIRE HOLE IS ROUND, SHALL BE CHAMFERRED AS NECESSARY TO FACILITATE INSTALLATION OF THE LARGEST SIZE WIRE.
8. THE TERMINAL SCREW MAY BE OF THE ALLEN TYPE (3/16 INCH ACROSS FLATS FOR 200A. IF STUD "A" IS A PART OF THE TERMINAL SCREW, THE TERMINAL SCREW SHALL BE 5/8 INCH HEX ACROSS FLATS.
9. STUD "A" SHALL BE LOCATED IN THE CLEAR AREA BETWEEN THE TERMINATING LUG AND THE CIRCUIT-CLOSING NUT, AND MAY BE POSITIONED ON THE TERMINAL BODY, ON THE TERMINAL SCREW, ON THE BUS MEMBER, OR INCORPORATED AS PART OF THE WIRE STOP.

 	INITIATED BY	SC	REVISION NO.	8	SR-410 Pg. 5 of 10
	ESR COMM.	8-77	ESR COMM.	9-20	
			EFFECTIVE DATE	9-20	

USE: SELF-CONTAINED
METERING SINGLE
AND THREE-PHASE,
FOUR WIRE SERVICE,
MAX. 200A, 0-600V

SAFETY SOCKET BOX, TEST-BYPASS BLOCK
AND SWITCHBOARDS



EUSERC DWG.
NO. 306



SWITCHBOARDS
200A MAXIMUM

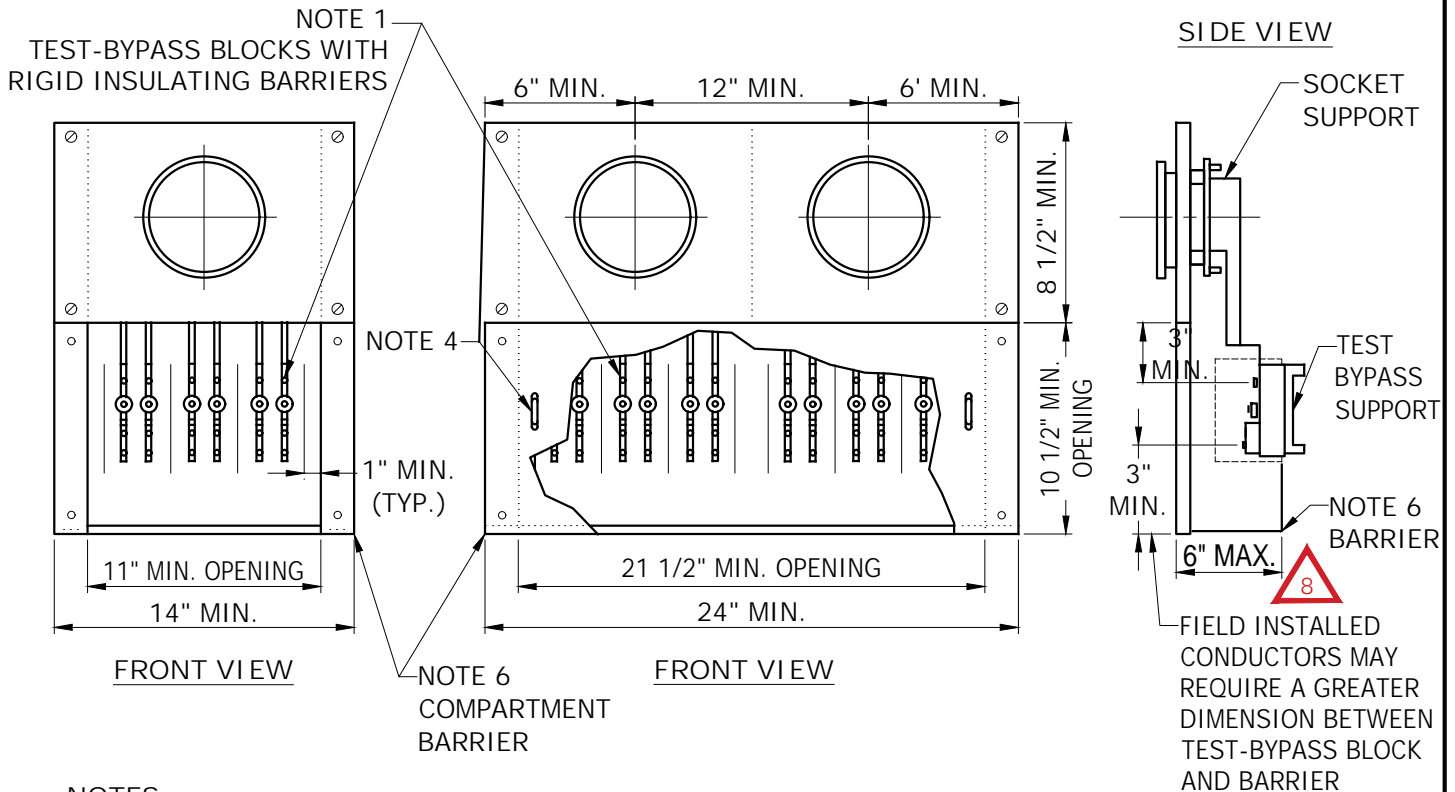

NOTES:

1. TEST-BYPASS BLOCKS WITH RIGID INSULATING BARRIERS SHALL BE FURNISHED, INSTALLED, AND WIRED OR BUSSED TO THE METER SOCKET BY THE MANUFACTURER. CONNECTION SEQUENCE IS LINE-LOAD FROM LEFT TO RIGHT.
2. METERED CONDUCTORS SHALL NOT PASS THROUGH ADJACENT METERING COMPARTMENTS EXCEPT IN ENCLOSED WIREWAYS. TO INSURE PROPER IDENTIFICATION OF CABLES IN FACTORY CABLED EQUIPMENT, METERED CABLES (EXCEPT IN THE TEST-BYPASS AREA), SHALL BE EITHER PHYSICALLY BARRIERED OR BUNDLED SO AS TO SEPARATE THEM FROM UNMETERED CABLE OR PERMANENTLY MARKED AND ISOLATED FROM UNMETERED CABLES. PHYSICAL BARRIERS WILL NOT BE REQUIRED IF THE UNMETERED CONDUCTORS ARE BUS.
3. METER PANELS SHALL BE REMOVABLE WITH A MAXIMUM OF TWO METERS PER PANEL. BREAKERS MUST BE SEALABLE IN THE OFF POSITION WITH A TEP OR SERVICE PROVIDER SEAL, OR INDIVIDUAL BREAKERS MUST HAVE INDIVIDUAL SEALABLE COVERS.
4. TEST- BYPASS BLOCK COVER PANEL SHALL BE SEALABLE AND FITTED WITH A LIFTING HANDLE. ALL PANELS EXCEEDING 16" IN WIDTH SHALL REQUIRE TWO LIFTING HANDLES.
5. WHEN A NEUTRAL IS REQUIRED FOR METERING OR TESTING, AN INSULATED NEUTRAL TERMINAL SHALL BE PROVIDED BEHIND EACH TEST-BYPASS COVER PANEL. THE TERMINAL SHALL BE READILY ACCESSIBLE WHEN THE COVER PANEL IS REMOVED AND SHALL BE INDIVIDUALLY CONNECTED TO THE NEUTRAL BUS WITH A MINIMUM SIZE NO. 8 COPPER WIRE.

USE: SELF-CONTAINED
METERING SINGLE
AND THREE-PHASE,
FOUR WIRE SERVICE,
MAX. 200A, 0-600V

SAFETY SOCKET BOX, TEST-BYPASS BLOCK
AND SWITCHBOARDS





EUSERC DWG.
NO. 306



NOTES (CONTINUED):

6. FACTORY INSTALLED FULL WIDTH INSULATING BARRIER WITH A MAXIMUM DEFLECTION OF 1/2 INCH FROM AN APPLIED FORCE OF 25 POUNDS DOWNWARD, SHALL BE LOCATED AT THE BOTTOM OF EACH TEST BY-PASS COMPARTMENT.
7. FOR THREE-PHASE, 4 WIRE, CONNECT 7TH JAW TO BODY OF NEUTRAL LUG WITH NO. 12 MINIMUM. COPPER WIRE, WHITE IN COLOR.
8. FOR THREE-PHASE, 240/120V, 4 WIRE DELTA, IDENTIFY RIGHT-HAND TEST-BYPASS BLOCK (2 POLES) AS POWER LEG. IDENTIFICATION TO BE ORANGE IN COLOR (NOT AVAILABLE FOR NEW SERVICE).
9. FOR SINGLE-PHASE, 3 WIRE, PROVIDE TWO TEST-BYPASS BLOCKS MOUNTED IN THE OUTER POSITIONS, AND A FOUR JAW SOCKET.
10. FOR SINGLE-PHASE, 3 WIRE, 120/208V, PROVIDE TWO TEST-BYPASS BLOCKS MOUNTED IN THE OUTER POSITION AND A 5 JAW SOCKET. CONNECT 5TH JAW TO BODY OF NEUTRAL LUG WITH NO. 12 MIN. COPPER WIRE, WHITE IN COLOR.
11. METER PANELS SHALL BE REMOVABLE BUT SHALL BE NON-REMOVABLE WHEN METER IS IN PLACE. METER SOCKET IS TO BE SUPPORTED INDEPENDENT OF AND ATTACHED TO METER PANEL.
12. SEPARATE LINE AND LOAD CONDUCTORS SHALL BE INSTALLED BY THE CONTRACTOR OR MANUFACTURER FOR EACH METER SOCKET.
13. EACH LINE AND LOAD POSITION SHALL BE CLEARLY IDENTIFIED 3/4 INCH MINIMUM BLOCK LETTER LABELING.
14. ALL SECURING SCREWS SHALL BE CAPTIVE. ALL PANELS SHALL BE SEALABLE.

		INITIATED BY	SC	REVISION NO.	9	SR-410 Pg. 7 of 10
		ESR COMM.	8-77	ESR COMM.	9-20	
				EFFECTIVE DATE	9-20	

USE: SINGLE-PHASE,
120/240V, 100A &
200A, 4 TERMINAL

SAFETY SOCKET BOX, TEST-BYPASS BLOCK AND SWITCHBOARDS

EUSERC DWG.
NO. 304 & 305

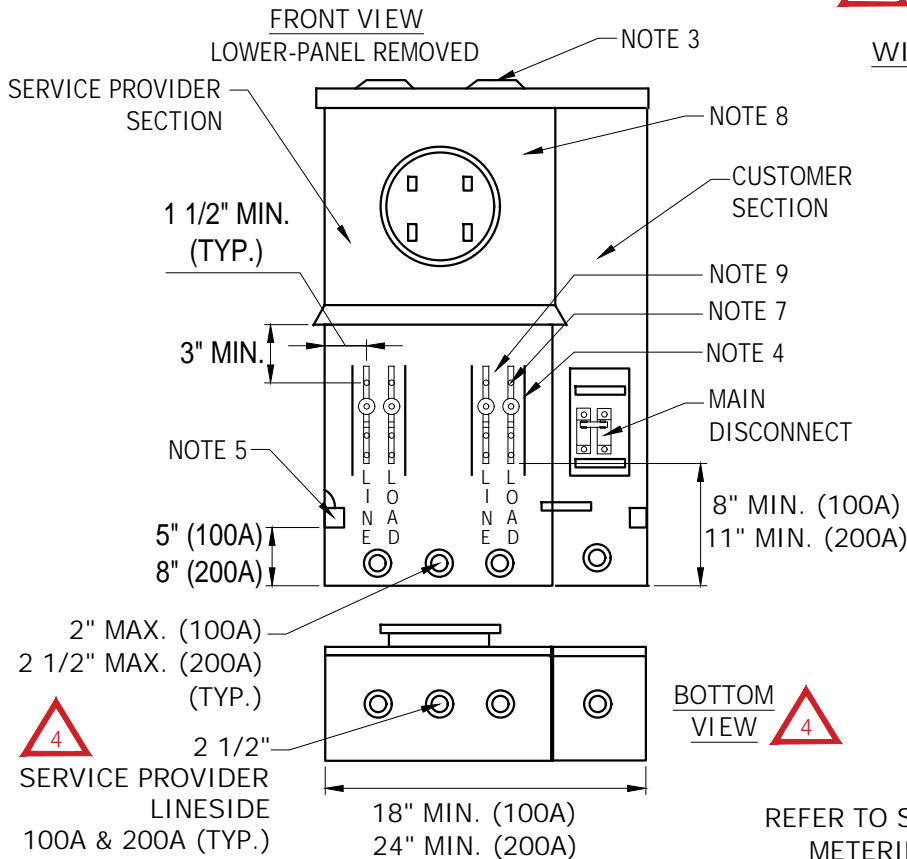

SAFETY SOCKET WITH MAIN DISCONNECT

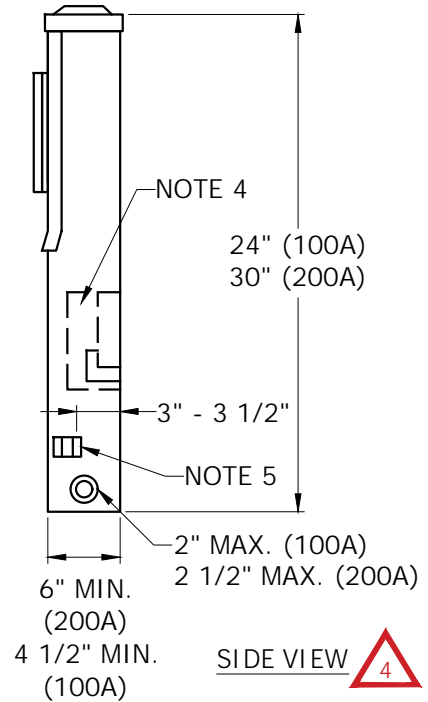

REFER TO SR-452 FOR THE COMPLETE APPROVED
METERING AND SERVICE EQUIPMENT LIST

NOTES:

- THIS DEVICE MAY BE USED FOR TERMINATING/PULLING AND METER SOCKET BOX FOR AN UNDERGROUND SERVICE.
- ALUMINUM BODIED TERMINALS FOR NO. 6 THROUGH NO. 1/0AWG WIRE (100A) OR 1/0AWG THROUGH 250 KCMIL (200A).
- UNUSED HUBS CAPPED OFF WITH A RAINPROOF ACCESS PLATE(S) THAT IS SECURED INTERNALLY UTILIZING A CARRIAGE BOLT AND A WINGNUT BAR THAT SPANS BEYOND THE OPENING. SEE SR-405.
- RIGID INSULATING BARRIERS.
- INSULATED BONDABLE VERTICAL LAY-IN, DOUBLE NEUTRAL LUG WITH NO. 1/0 (100A), NO. 250 KCMIL, (200A) AWG WIRE CAPACITY MOUNTED ON EITHER SIDEWALL. NEUTRAL LUG SHALL BE BONDED TO ENCLOSURE.
- TEST-BYPASS BLOCKS SHALL BE BUSSED OR WIRED TO SOCKET JAWS OR TERMINALS.
- UPPER TEST CONNECTOR STUDS.
- ALL SECTION PANELS SHALL BE INDEPENDENTLY REMOVABLE. UPPER PANEL SHALL BE NON-REMOVABLE WHEN METER IS IN PLACE. METER SOCKET SHALL BE MOUNTED ON SUPPORT AND ATTACHED TO UPPER PANEL. LOWER PANEL SHALL BE SEALABLE AND PERMANENTLY LABELED, "DO NOT BREAK SEALS, NO FUSES INSIDE".
- TEST-BYPASS BLOCK DETAIL. SEE SR-410, PAGE 3.
- FOR SINGLE-PHASE, 3 WIRE, PROVIDE TWO TEST-BYPASS BLOCKS MOUNTED IN THE OUTER POSITIONS AND A FOUR JAW SOCKET (FORM 2 METER).
- PERMANENT LABEL ON INSIDE BACK OF ENCLOSURE IS 3/4 INCH MINIMUM HIGH BLOCK LETTERS.
- FOR SWITCHBOARD APPLICATION, REFER TO SR-410, PAGE 6.
- THIS SOCKET IS REQUIRED FOR MULTI-METERED COMMERCIAL APPLICATIONS, SEE SR-418.
- REFER TO SR-408, PAGES 1, 3 & 4 FOR SOCKET REQUIREMENTS FOR PERMANENTLY UNOCCUPIED COMMERCIAL INSTALLATIONS SUCH AS WATER WELLS, BILLBOARDS, IRRIGATION SYSTEMS, ETC., WHERE A BYPASS SYSTEM IS NOT NEEDED.
- MINIMUM WIDTH OF ACCESS OPENING SHALL BE 11-1/2" FOR 100A, 13-1/2" FOR 200A SOCKET.
- WHEN INSTALLING A SAFETY SOCKET FOR METERING OF STREET LIGHT INSTALLATIONS OR IN PARKS, SCHOOL YARDS AND OTHER AREAS SUBJECT TO VANDALISM, INSTALL A PROTECTIVE COVER (METER DEVICES/BROOKS CAT. #4042) ON THE METER BASE.



		INITIATED BY	GC	REVISION NO.	4	SR-410
		ESR COMM.	10-04	ESR COMM.	9-20	
				EFFECTIVE DATE	9-20	

USE: SINGLE-PHASE,
 120/208V, 120/240V,
 100A & 200A, 5 TERMINAL

SAFETY SOCKET BOX, TEST-BYPASS BLOCK AND SWITCHBOARDS

EUSERC DWG.
 NO. 304 & 305

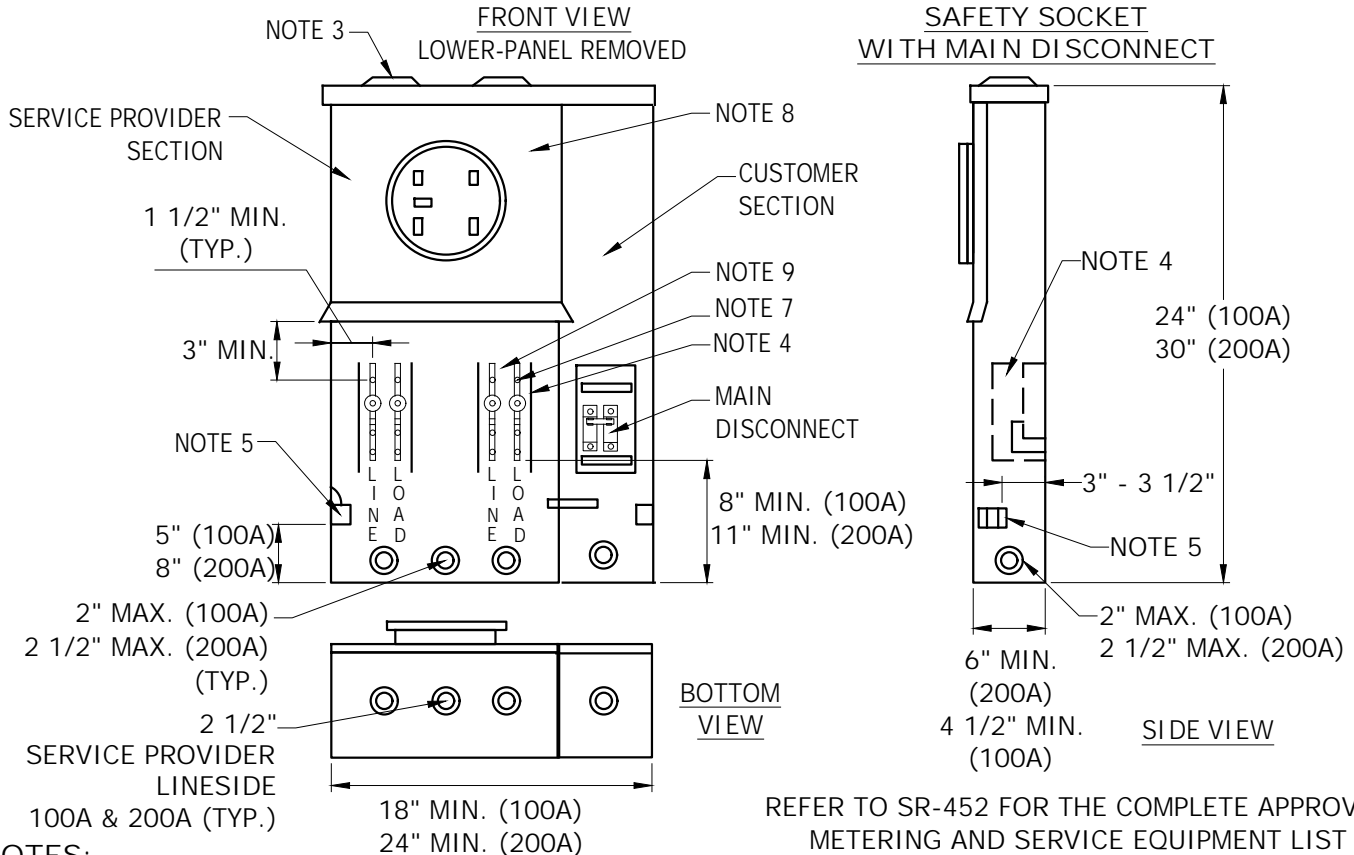

REFER TO SR-452 FOR THE COMPLETE APPROVED
 METERING AND SERVICE EQUIPMENT LIST

NOTES:

1. THIS DEVICE MAY BE USED FOR TERMINATING/PULLING AND METER SOCKET BOX FOR AN UNDERGROUND SERVICE.
2. ALUMINUM BODIED TERMINALS FOR NO. 6 THROUGH NO. 1/0AWG WIRE (100A) OR 1/0 AWG THROUGH 250 KCMIL (200A).
3. UNUSED HUBS CAPPED OFF WITH A RAINPROOF ACCESS PLATE(S) THAT IS SECURED INTERNALLY UTILIZING A CARRIAGE BOLT AND A WINGNUT BAR THAT SPANS BEYOND THE OPENING, SEE SR-405.
4. RIGID INSULATING BARRIERS.
5. INSULATED BONDABLE VERTICAL LAY-IN, DOUBLE NEUTRAL LUG WITH NO. 1/0 (100A), NO. 250 KCMIL (200A), AWG WIRE CAPACITY MOUNTED ON EITHER SIDEWALL. NEUTRAL LUG SHALL BE BONDED TO ENCLOSURE.
6. TEST-BYPASS BLOCKS SHALL BE BUSSED OR WIRED TO SOCKET JAWS OR TERMINALS.
7. UPPER TEST CONNECTOR STUDS.
8. ALL SECTION PANELS SHALL BE INDEPENDENTLY REMOVABLE. UPPER PANEL SHALL BE NON-REMOVABLE WHEN METER IS IN PLACE. METER SOCKET SHALL BE MOUNTED ON SUPPORT AND ATTACHED TO UPPER PANEL. LOWER PANEL SHALL BE SEALABLE AND PERMANENTLY LABELED, "DO NOT BREAK SEALS, NO FUSES INSIDE".
9. TEST-BYPASS BLOCK DETAIL. SEE SR-410, PAGE 3.
10. FOR SINGLE-PHASE, 3 WIRE, 208V, FORM 12 METER, PROVIDE TWO TEST-BYPASS BLOCKS MOUNTED IN THE OUTER POSITION AND A FIVE JAW SOCKET. CONNECT 5TH JAW OF METER SOCKET TO BODY OF NEUTRAL LUG WITH #12 MIN. COPPER WIRE, WHITE IN COLOR. THE 5TH JAW OF THE METER SOCKET IS TO BE SECURELY ATTACHED TO THE METER SOCKET.
11. PERMANENT LABEL ON INSIDE BACK OF ENCLOSURE IS 3/4 INCH MINIMUM HIGH BLOCK LETTERS.
12. FOR SWITCHBOARD APPLICATION, REFER TO SR-410, PAGE 6.
13. THIS SOCKET IS REQUIRED FOR MULTI-METERED COMMERCIAL APPLICATIONS, SR-418.
14. REFER TO SR-408, PAGES 1, 3 AND 4 FOR SOCKET REQUIREMENTS FOR PERMANENTLY UNOCCUPIED COMMERCIAL INSTALLATIONS SUCH AS WATER WELLS, BILLBOARDS, IRRIGATION SYSTEMS, ETC., WHERE A BYPASS SYSTEM IS NOT NEEDED.
15. MINIMUM WIDTH OF ACCESS OPENING SHALL BE 11-1/2" FOR 100A, 13-1/2" FOR 200A SOCKET.
16. WHEN INSTALLING A SAFETY SOCKET FOR METERING OF STREET LIGHT INSTALLATIONS OR IN PARKS, SCHOOL YARDS AND OTHER AREAS SUBJECT TO VANDALISM, INSTALL A PROTECTIVE COVER (METER DEVICES/BROOKS CAT. #4042) ON THE METER BASE.

Tucson Electric Power	SANTA CRUZ COUNTY	INITIATED BY	GC	REVISION NO.	5	SR-410
		ESR COMM.	10-04	ESR COMM.	11-21	
				EFFECTIVE DATE	11-21	

USE: THREE-PHASE,
120/208V, 120/240V,
277/480V, 240/480V,
100A & 200A, 7 TERMINAL

SAFETY SOCKET BOX, TEST-BYPASS BLOCK AND SWITCHBOARDS



EUSERC DWG.
NO. 304 & 305

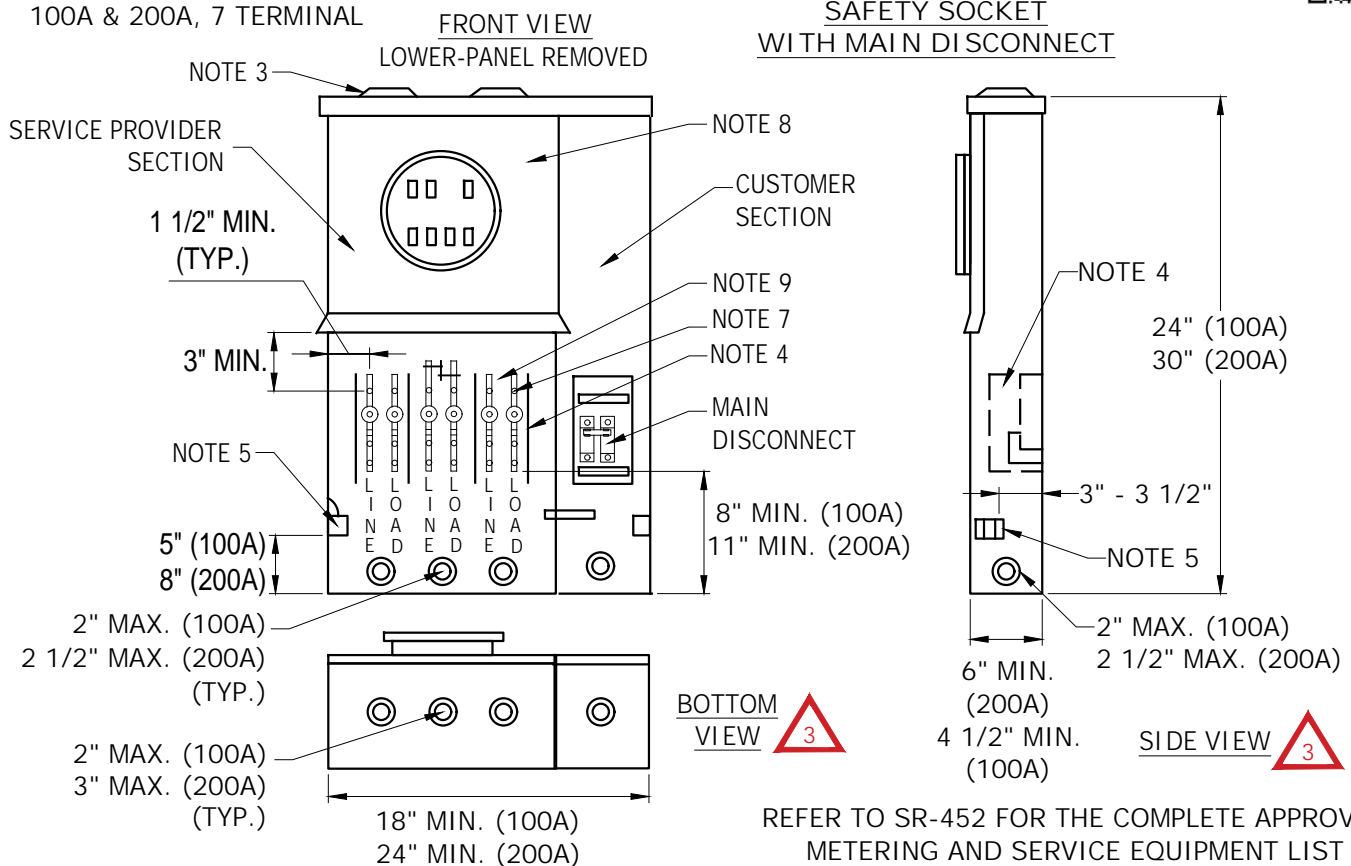

REFER TO SR-452 FOR THE COMPLETE APPROVED
METERING AND SERVICE EQUIPMENT LIST

NOTES:

1. THIS DEVICE MAY BE USED FOR TERMINATING/PULLING AND METER SOCKET BOX FOR AN UNDERGROUND SERVICE.
2. ALUMINUM BODIED TERMINALS FOR NO. 6 THROUGH NO. 1/0 AWG WIRE (100 A) OR 1/0 AWG THROUGH 250 KCMIL (200A).
3. UNUSED HUBS CAPPED OFF WITH A RAINPROOF ACCESS PLATE(S) THAT IS SECURED INTERNALLY UTILIZING A CARRIAGE BOLT AND A WINGNUT BAR THAT SPANS BEYOND THE OPENING, SEE SR-405.
4. RIGID INSULATING BARRIERS.
5. INSULATED BONDABLE VERTICAL LAY-IN, DOUBLE NEUTRAL LUG WITH NO. 1/0 (100 A), NO. 250 KCMIL (200 A), AWG WIRE CAPACITY MOUNTED ON EITHER SIDEWALL. NEUTRAL LUG SHALL BE BONDED TO ENCLOSURE.
6. TEST-BYPASS BLOCKS SHALL BE BUSSED OR WIRED TO SOCKET JAWS OR TERMINALS.
7. UPPER TEST CONNECTOR STUDS.
8. ALL SECTION PANELS SHALL BE INDEPENDENTLY REMOVABLE. UPPER PANEL SHALL BE NON-REMOVABLE WHEN METER IS IN PLACE. METER SOCKET SHALL BE MOUNTED ON SUPPORT AND ATTACHED TO UPPER PANEL. LOWER PANEL SHALL BE SEALABLE AND PERMANENTLY LABELED, "DO NOT BREAK SEALS, NO FUSES INSIDE."
9. TEST-BYPASS BLOCK DETAIL. SEE SR-410, PAGE 3.
10. FOR THREE-PHASE, 4 WIRE, CONNECT 7TH JAW TO BODY OF NEUTRAL LUG WITH #12 AWG COPPER WIRE, WHITE IN COLOR (SEVEN JAW SOCKET).
11. FOR THREE-PHASE, 240/480V, 4 WIRE DELTA, IDENTIFY RIGHT HAND SIDE OF THE TEST-BYPASS BLOCK, LINE AND LOAD SIDE (2 POLES) AS THE POWER LEG (SEVEN JAW SOCKET).
12. PERMANENT LABEL ON INSIDE BACK OF ENCLOSURE IS 3/4 INCH MINIMUM HIGH BLOCK LETTERS.
13. FOR SWITCHBOARD APPLICATION, REFER TO SR-410, PAGE 6.
14. THIS SOCKET IS REQUIRED FOR MULTI-METERED COMMERCIAL APPLICATIONS, SR-418.
15. REFER TO SR-408, PAGE 1, 3 AND 4 FOR SOCKET REQUIREMENTS FOR PERMANENTLY UNOCCUPIED COMMERCIAL INSTALLS SUCH AS WATER WELLS, BILLBOARDS, IRRIGATION SYSTEMS, ETC., WHERE A BYPASS SYSTEM IS NOT NEEDED.
16. MINIMUM WIDTH OF ACCESS OPENING SHALL BE 11 1/2" FOR 100A, 13 1/2" FOR 200A SOCKET.
17. WHEN INSTALLING A SAFETY SOCKET FOR METERING OF STREET LIGHTS OR IN PARKS, SCHOOL YARDS AND OTHER AREAS SUBJECT TO VANDALISM, INSTALL A PROTECTIVE COVER (METER DEVICES/BROOKS CAT. #4042) ON THE METER BASE.

USE: COMMERCIAL OR RESIDENTIAL, UG OR OH 120/240V, 201-400A, WITH BYPASS CAPABILITY

SINGLE-PHASE, OVERHEAD OR UNDERGROUND, METER PANEL AND COMBINATION METER DISTRIBUTION SECTION, BY-PASS CAPABLE

EUSERC DWG. NO. 302B



REFER TO SR-452 FOR THE COMPLETE APPROVED METERING AND SERVICE EQUIPMENT LIST

PROVISIONS FOR UP TO AND INCLUDING 4 INCH CONDUIT IN THE CENTER POSITION

METER SOCKET (NOTES 2 & 4)

MANUAL BYPASS STUDS (NOTE 3)

1 1/8" MIN.

13 HEX SCREW LUG (NOTE 6 & 10)

15 1/2" MIN.

1 1/2"

1 1/2"

1 1/2"

NEUTRAL BONDED TO ENCLOSURE

8 1/2" MIN.

PROVISIONS FOR UP TO AND INCLUDING 4 INCH CONDUIT IN THE CENTER POSITION

FRONT VIEW

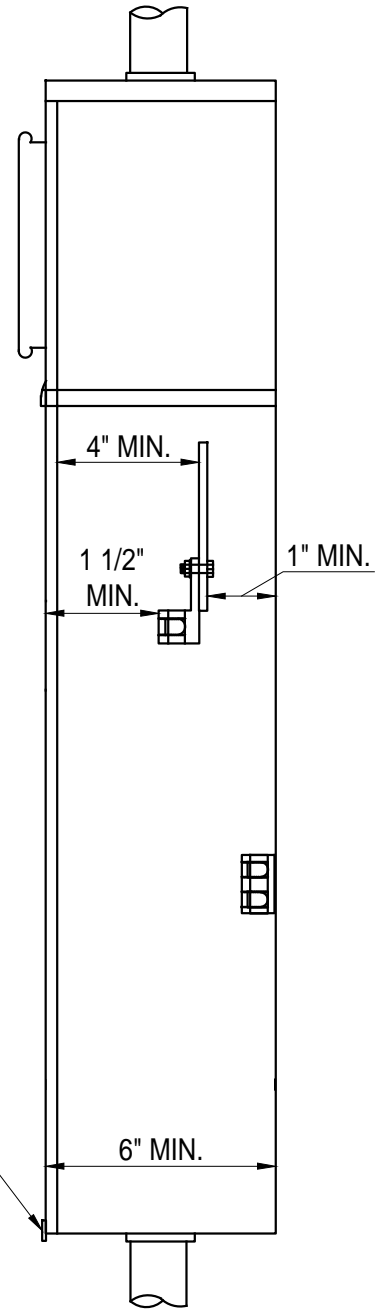





SIDE VIEW



USE: COMMERCIAL OR
RESIDENTIAL, OH OR UG,
120/240V, 201-400A,
WITH BYPASS CAPABILITY

SINGLE-PHASE, OVERHEAD OR
UNDERGROUND, METER PANEL AND
COMBINATION METER DISTRIBUTION
SECTION, BY-PASS CAPABLE



NOTES:

1. This service equipment shall be listed by an approved testing laboratory and marked with a continuous ampere rating of 320 amperes. Alternatively, it may be marked "400 amps" (320 amperes continuous)".
2. Only ring type sockets are acceptable. For ring-type meter panels, the panel shall be provided with a sealing ring and the meter socket shall be rigidly mounted on a support and attached to the meter panel.
3. 12-24 bypass studs, 1/2 inch height with 1/2 inch hex-nut (measured across the flat) shall be provided on each phase bus section. The studs shall have a horizontal spacing of 1 1/2 inch (measured from the centers) between the line and load bus sections, and shall be offset from the line side termination lugs to permit cable entry from the top without interference with the service provider's manual bypass links.
-  4. Socket cover panels shall be removable, sealable and rainproof. The socket cover panel shall be provided with a sealing ring and shall not be removable with the meter in place.
5. The bypass and cable termination compartment cover panel shall be independent of the meter panel and it shall be removable, lockable and sealable.
6. Termination for service conductors shall be aluminum-bodied mechanical lugs with a range of 1/0 AWG - 350 KCMIL. The lugs shall be secured to assure vertical alignment and line side lugs shall be offset from the face of the bus to permit cable entry from the top. The line and load positions shall be identified in 3/4 inch block letters.
-  7. If insulating material is provided the 1 1/2 inch dimension may be reduced between the line and load bus sections.
8. If panel is installed as an upgrade, the Service Provider will not splice underground service cable in order to terminate to the new panel. If additional cable length is required due to meter base changeout the customer will be required to lower the meter socket to obtain sufficient length or provide a new continuous conduit system (including new service riser) to the Company equipment. Design Services will determine if the current service conductor is adequate for the service entrance amperage. If the current conductor meets the Service Provider's design needs and is damaged, the replacement of the conductor will be billable. See Note 12.
-  9. This panel is the replacement for the K-4U meter socket, this includes the K-4U all-in-one load centers. The K-4U (bolt in meter) style panel is no longer approved.
-  10. Customer shall provide the terminal connectors with a connector range of 1/0 AWG - 350 KCMIL per the specifications stated in Note 2, Page 2 of SR-425.
11. Customer owned conductors shall not pass through the pull section or meter socket section.
-  12. For all underground service entrance panels rated at 320A or 400A, regardless of whether installation is new service or service upgrade the customer will be required to install a 2 1/2 inch continuous conduit system, unless such system already exists.

 Tucson Electric Power	 UniSource Energy SERVICES SANTA CRUZ COUNTY	INITIATED BY	GC	REVISION NO.	3	SR-412 Pg. 2 of 4
		ESR COMM.	8-06	ESR COMM.	5-22	
				EFFECTIVE DATE	5-22	

USE: COMMERCIAL OR RESIDENTIAL, UG, 120/240V, 400A (320A CONTINUOUS), WITH BYPASS CAPABILITY

SINGLE-PHASE, OVERHEAD OR UNDERGROUND METER PANEL WITH BYPASS STUDS AND COMBINATION METER DISTRIBUTION SECTION

EUSERC DWG. NO. 302



REFER TO SR-452 FOR THE COMPLETE APPROVED METERING AND SERVICE EQUIPMENT LIST

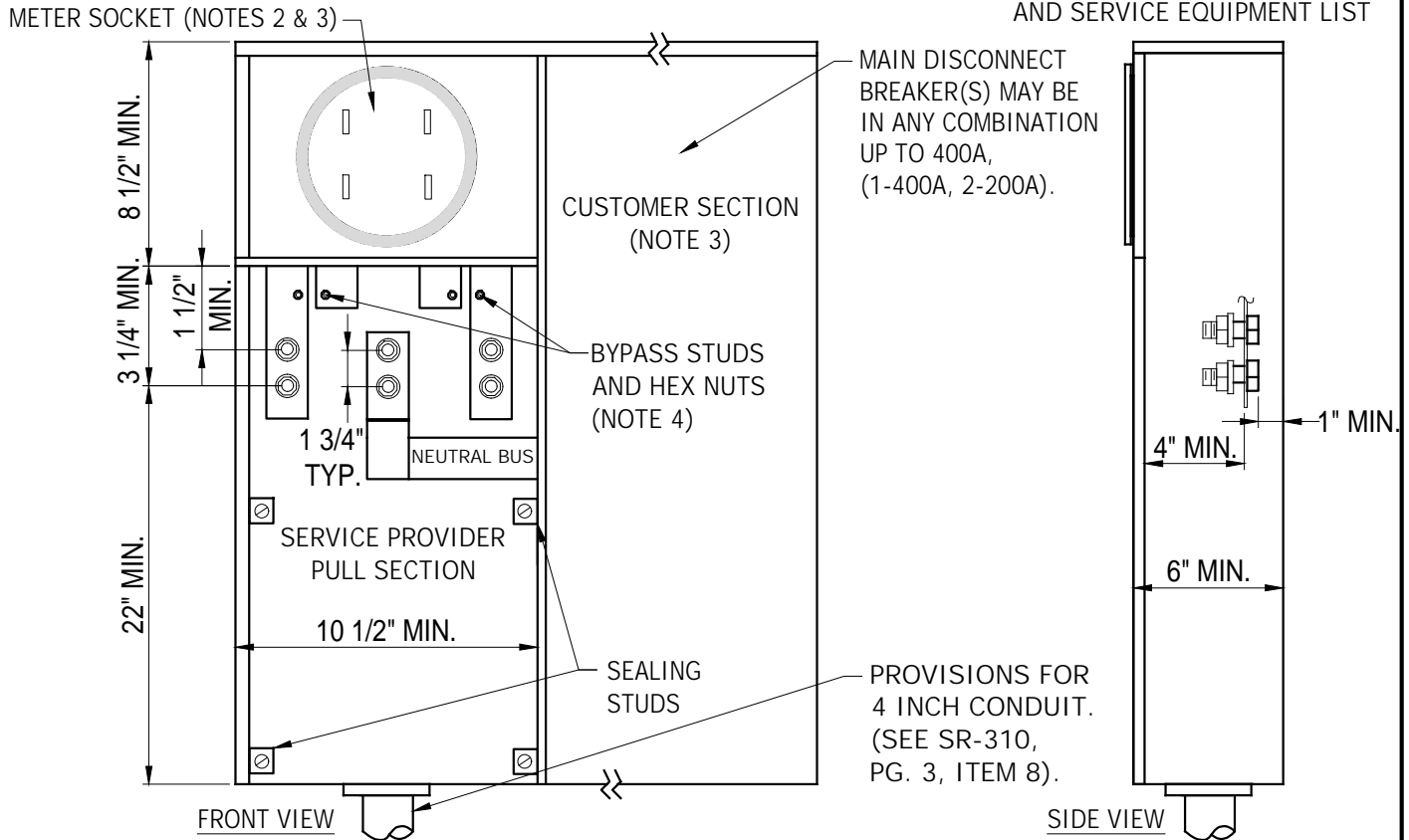

NOTES:

1. THIS SERVICE EQUIPMENT SHALL BE LISTED BY AN APPROVED TESTING LABORATORY AND MARKED WITH A CONTINUOUS AMPERE RATING OF 320 AMPERES. ALTERNATIVELY, IT MAY BE MARKED "400 AMPS" (320 AMPERES CONTINUOUS)."
2. ONLY RING TYPE SOCKETS ARE ACCEPTABLE. SOCKET COVER PANELS SHALL BE REMOVABLE, SEALABLE AND RAINPROOF.
3. THE METER SOCKET MAY BE LOCATED ABOVE, TO THE LEFT, OR TO THE RIGHT OF THE UNDERGROUND PULL SECTION. A SINGLE UNIT WITH ONLY SERVICE TERMINATION FACILITIES AND METERING IS ALSO ACCEPTABLE.
4. MANUAL BYPASS FACILITIES SHALL BE PROVIDED FOR COMMERCIAL SERVICE ONLY, WHICH WILL MAINTAIN SERVICE CONTINUITY TO THE CUSTOMER WHILE THE METER IS REMOVED FOR TEST OR INSPECTION.
5. MANUAL BYPASS PROVISIONS WHICH DE-ENERGIZE THE METER SOCKET ARE PREFERRED BUT NOT REQUIRED FOR RESIDENTIAL INSTALLATION. (AUTOMATIC BYPASSES ARE UNACCEPTABLE). ▲ 1
6. CUSTOMER-OWNED WIRING EXTENDING FROM THE DISTRIBUTION SECTION (BRANCH CIRCUITS) SHALL NOT PASS THROUGH ANY SECTION SEALED BY THE SERVICE PROVIDER.
7. PULL SECTION COVER PANELS SHALL BE REMOVABLE, SEALABLE, PROVIDED WITH TWO LIFTING HANDLES, AND LIMITED TO A MAXIMUM SIZE OF 9 SQUARE FEET IN AREA. SEALING PROVISIONS SHALL CONSIST OF TWO DRILLED STUD AND WING NUT ASSEMBLIES ON OPPOSITE SIDES OF THE PANELS. ALL SECURING SCREWS SHALL BE CAPTIVE.
8. TERMINAL CONNECTORS WITH A CONNECTOR RANGE OF #1/0 AWG-350 KCMIL ARE TO BE PROVIDED AS PER THE SPECIFICATIONS STATED IN SR-425, PAGE 2, NOTE #2.
12. FOR ALL UNDERGROUND SERVICE ENTRANCE PANELS RATED AT 320A OR 400A, REGARDLESS OF WHETHER INSTALLATION IS NEW SERVICE OR SERVICE UPGRADE THE CUSTOMER WILL BE REQUIRED TO INSTALL A 2 1/2 INCH CONTINUOUS CONDUIT SYSTEM, UNLESS SUCH SYSTEM ALREADY EXISTS. ▲ 1

Tucson Electric Power	SANTA CRUZ COUNTY	INITIATED BY	GC	REVISION NO.	1	SR-412
		ESR COMM.	7-07	ESR COMM.	5-22	
				EFFECTIVE DATE	5-22	

USE: RESIDENTIAL AND UNOCCUPIED COMMERCIAL, UG, 120/240V, 320A CONTINUOUS

SINGLE-PHASE, OVERHEAD OR UNDERGROUND METER PANEL WITH BYPASS STUDS AND COMBINATION METER DISTRIBUTION SECTION

EUSERC DWG. NO. 302



REFER TO SR-452 FOR THE COMPLETE APPROVED METERING AND SERVICE EQUIPMENT LIST

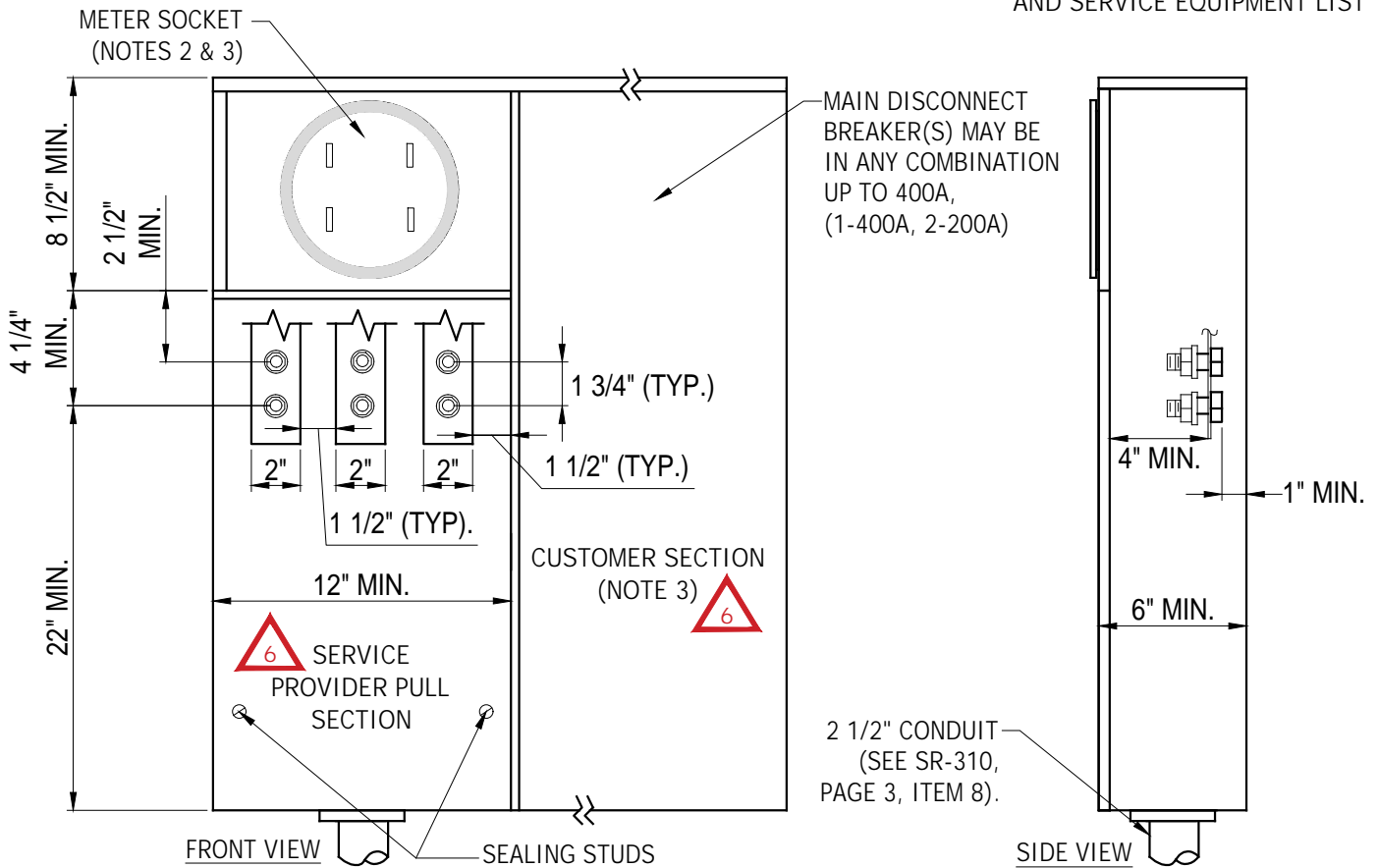

NOTES:

- THIS SERVICE EQUIPMENT SHALL BE LISTED BY AN APPROVED TESTING LABORATORY AND MARKED WITH A CONTINUOUS AMPERE RATING OF 320 AMPERES. ALTERNATIVELY, IT MAY BE MARKED "400 AMPS" (320 AMPERES CONTINUOUS).
- ONLY RING TYPE SOCKETS ARE ACCEPTABLE. SOCKET COVER PANELS SHALL BE REMOVABLE, SEALABLE AND RAINPROOF.
- THE METER SOCKET MAY BE LOCATED ABOVE, TO THE LEFT, OR TO THE RIGHT OF THE UNDERGROUND PULL SECTION. A SINGLE UNIT WITH ONLY SERVICE TERMINATION FACILITIES AND METERING IS ALSO ACCEPTABLE.
- CUSTOMER-OWNED WIRING EXTENDING FROM THE DISTRIBUTION SECTION (BRANCH CIRCUITS) SHALL NOT PASS THROUGH ANY SECTION SEALED BY THE SERVICE PROVIDER.
- PULL SECTION COVER PANELS SHALL BE REMOVABLE, SEALABLE, PROVIDED WITH TWO LIFTING HANDLES, AND LIMITED TO A MAXIMUM SIZE OF 9 SQUARE FEET IN AREA. SEALING PROVISIONS SHALL CONSIST OF TWO DRILLED STUD AND WING NUT ASSEMBLIES ON OPPOSITE SIDES OF THE PANELS. ALL SECURING SCREWS SHALL BE CAPTIVE.
- TERMINAL CONNECTORS WITH A CONNECTOR RANGE OF #1/0 AWG-350 KCMIL ARE TO BE PROVIDED AS PER THE SPECIFICATIONS STATED IN sr-425, PAGE 2, NOTE #2.
- SEE SR-412, PG. 1 OR 3 FOR SELF CONTAINED METERING FOR OCCUPIED COMMERCIAL INSTALLATIONS
- FOR ALL UNDERGROUND SERVICE ENTRANCE PANELS RATED AT 320A OR 400A, REGARDLESS OF WHETHER INSTALLATION IS NEW SERVICE OR SERVICE UPGRADE THE CUSTOMER WILL BE REQUIRED TO INSTALL A 2 1/2 INCH CONTINUOUS CONDUIT SYSTEM, UNLESS SUCH SYSTEM ALREADY EXISTS.



		INITIATED BY	CO	REVISION NO.	6	SR-412
		ESR COMM.	2-90	ESR COMM.	5-22	
				EFFECTIVE DATE	5-22	

USE: 120/240V, SINGLE-PHASE,
3-WIRE, 401A -800A

SOCKET REQUIREMENTS WITH INSTRUMENT TRANSFORMERS, SINGLE-PHASE AND THREE-PHASE

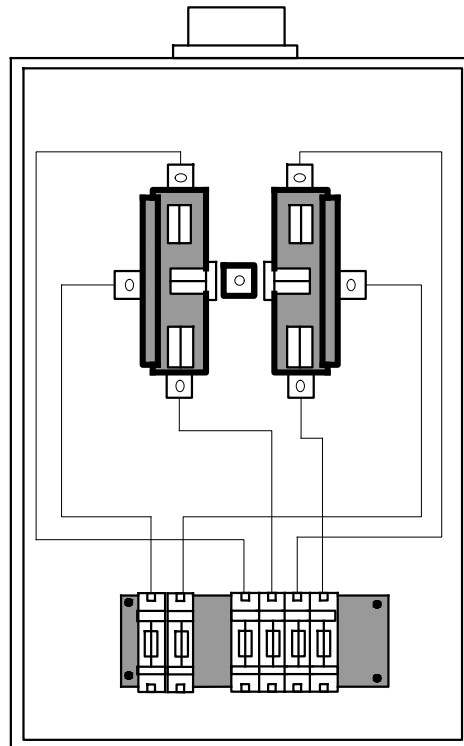

NOTES:

1. THE CUSTOMER SHALL PROVIDE AND INSTALL AN APPROVED 6 TERMINAL, RING-TYPE, PRE-WIRED SOCKET WITH TEST SWITCH, AS SHOWN.

APPROVED MANUFACTURERS:

DURHAM, CATALOG NO. RSTL6-2K503

DURHAM, CATALOG NO. RSTL6-2K978

MILBANK, CATALOG NO. UC7636-YL-TGE-DES

COOPER B-LINE, CATALOG NO. W12146

TESCO, CATALOG NO. 9070928-00



2. THE CUSTOMER SHALL PROVIDE AND INSTALL THE CONDUIT FOR THE METERING WIRE FROM THE CURRENT TRANSFORMERS (CT) ENCLOSURE TO THE METER SOCKET ENCLOSURE. CONDUIT SHALL ENTER THE METER SOCKET ENCLOSURE AT THE HUB OR THE PRECUT KNOCK-OUTS AND MEET THE FOLLOWING REQUIREMENTS;

- a. CONDUIT SHALL NOT INTERFERE WITH THE OPERATION OF THE TEST SWITCH.
- b. METERING CONDUIT SHALL NOT HAVE MORE THAN THREE 90 DEGREE BENDS, OR ANY COMBINATION OF BENDS GREATER THAN 270 DEGREES.
- c. THE METERING CONDUIT SHALL NOT EXCEED 120 FEET IN LENGTH.
- d. 2 INCH CONDUIT IS REQUIRED FOR RUNS THAT ARE IN EXCESS OF 50 FEET. 1 1/4 INCH CONDUIT MAY BE USED IF LENGTH IS 50 FEET OR LESS AND BENDS DO NOT EXCEED 90 DEGREES.
- e. A PULL ROPE MUST BE INSTALLED IN CONDUIT RUNS IN EXCESS OF 50 FEET.
- f. ACCESSIBLE AND SEALABLE PULLING JUNCTIONS MUST BE APPROVED BY DESIGN SERVICES AND MAY NOT BE MODIFIED, AS MODIFICATION WOULD VOID THE UL LISTING OF THE EQUIPMENT.
- g. CONDUIT SHALL ENTER CT ENCLOSURE SUCH THAT IT IS NOT BLOCKED BY THE BUS BARS, REFER TO SR-422 FOR APPROVED CONDUIT ENTRANCE LOCATIONS AND TYPICAL CT ENCLOSURES.



3. SERVICE PROVIDER WILL PROVIDE METERING WIRE FROM CURRENT TRANSFORMERS TO TEST SWITCH.

4. AUTOMATIC CIRCUIT CLOSING DEVICES ARE NOT PERMITTED IN SOCKETS USED ON SERVICE PROVIDER'S SYSTEM .

USE: THREE-PHASE,
201A - 4000A &
PRIMARY METERING

SOCKET REQUIREMENTS WITH INSTRUMENT TRANSFORMERS SINGLE-PHASE AND THREE-PHASE

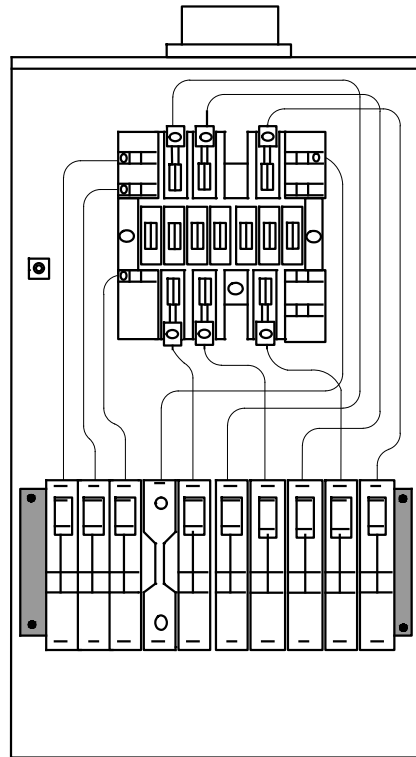

NOTES:

1. THE CUSTOMER SHALL PROVIDE AND INSTALL AN APPROVED 13 TERMINAL, RING-TYPE, PRE-WIRED SOCKET WITH TEST SWITCH, AS SHOWN.

APPROVED MANUFACTURERS:

DURHAM, CATALOG NO. RSTL13-2K504

DURHAM, CATALOG NO. RSTL13-2K979

MILBANK, CATALOG NO. UC7461-YL-TGE-DES

COOPER B-LINE, CATALOG NO. W121413

TESCO, CATALOG NO. 9070929-00



2. THE CUSTOMER SHALL PROVIDE AND INSTALL THE CONDUIT FOR THE METERING WIRE FROM THE CURRENT TRANSFORMERS (CT) ENCLOSURE TO THE METER SOCKET ENCLOSURE. CONDUIT SHALL ENTER THE METER SOCKET ENCLOSURE AT THE HUB OR THE PRECUT KNOCK-OUTS AND MEET THE FOLLOWING REQUIREMENTS;
 - a. CONDUIT SHALL NOT INTERFERE WITH THE OPERATION OF THE TEST SWITCH.
 - b. METERING CONDUIT SHALL NOT HAVE MORE THAN THREE 90 DEGREE BENDS, OR ANY COMBINATION OF BENDS GREATER THAN 270 DEGREES.
 - c. THE METERING CONDUIT SHALL NOT EXCEED 120 FEET IN MAXIMUM LENGTH.
 - d. 2 INCH CONDUIT IS REQUIRED FOR RUNS THAT ARE IN EXCESS OF 50 FEET. 1 1/4 INCH CONDUIT MAY BE USED IF LENGTH IS 50 FEET OR LESS AND BENDS DO NOT EXCEED 90 DEGREES.
 - e. A PULL ROPE MUST BE INSTALLED IN CONDUIT RUNS IN EXCESS OF 50 FEET.
 - f. ACCESSIBLE AND SEALABLE PULLING JUNCTIONS MUST BE APPROVED BY DESIGN SERVICES AND MAY NOT BE MODIFIED, AS MODIFICATION WOULD VOID THE UL LISTING OF THE EQUIPMENT.
 - g. CONDUIT SHALL ENTER CT ENCLOSURE SUCH THAT IT IS NOT BLOCKED BY THE BUS BARS, REFER TO SR-422 FOR APPROVED CONDUIT ENTRANCE LOCATIONS AND TYPICAL CT ENCLOSURES.
3. SERVICE PROVIDER WILL PROVIDE METERING WIRE FROM CURRENT TRANSFORMERS TO TEST SWITCH.
4. AUTOMATIC CIRCUIT CLOSING DEVICES ARE NOT PERMITTED IN SOCKETS USED ON SERVICE PROVIDER'S SYSTEM .

		INITIATED BY	SC	REVISION NO.	25	SR-414 Pg. 2 of 2
		ESR COMM.	8-77	ESR COMM.	7-25	
				EFFECTIVE DATE	7-25	

USE: COMMERCIAL AND RESIDENTIAL MULTI-METER INSTALLATIONS (0-800AMP). NOT INTENDED FOR TEMPORARY SERVICE INSTALLATIONS.

RESIDENTIAL AND COMMERCIAL MULTI-METERING INSTALLATIONS

MODIFIED EUSERC DWG. G2



REFER TO SR-452 FOR THE COMPLETE APPROVED METERING AND SERVICE EQUIPMENT LIST

UNDERGROUND INSTALLATION

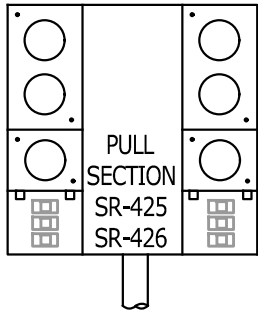

FIGURE 1

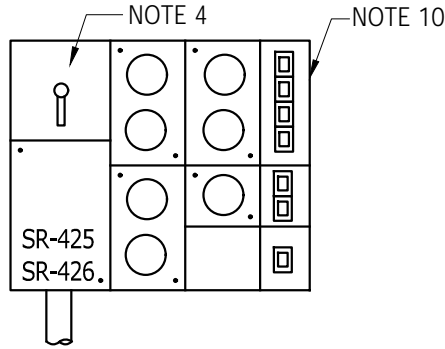

FIGURE 2

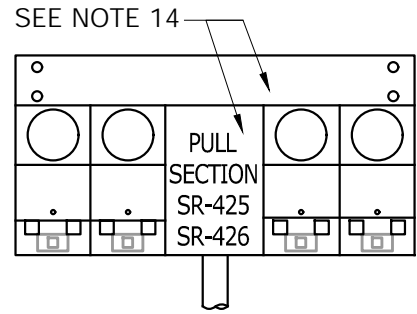

FIGURE 3

OVERHEAD INSTALLATION

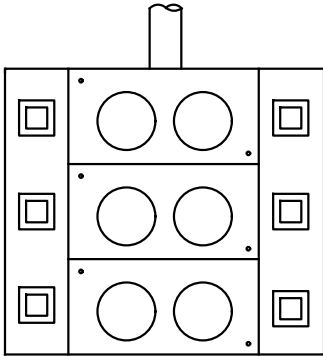

FIGURE 4

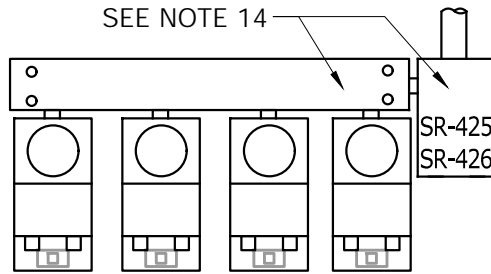

FIGURE 5

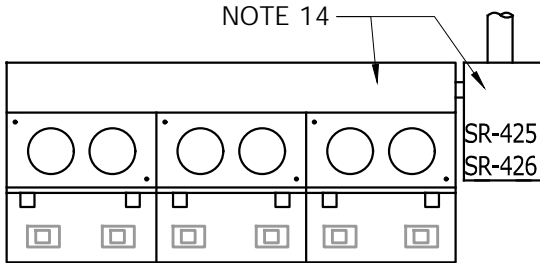
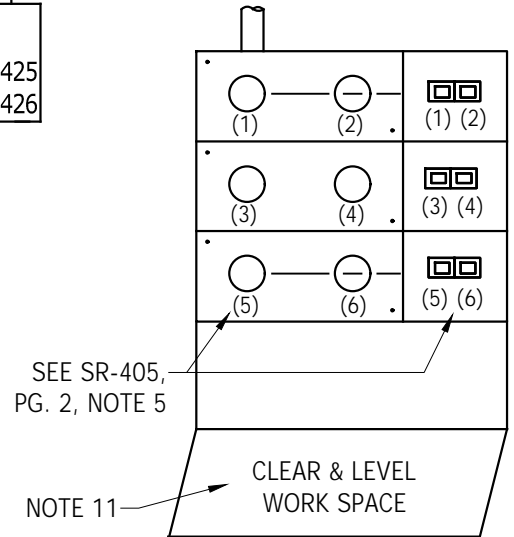

FIGURE 6



TYPICAL IDENTIFICATIONS



NOTE: DRAWINGS REPRESENT TYPICAL CONFIGURATIONS BUT MAY NOT ILLUSTRATE ALL CONFIGURATIONS FOR MULTI-METER INSTALLATION. CONSULT DESIGN SERVICES FOR REVIEW OF OTHER CONFIGURATIONS.

USE: COMMERCIAL AND
RESIDENTIAL MULTI-METER
INSTALLATIONS (0-800AMP).
NOT INTENDED FOR TEMPORARY
SERVICE INSTALLATIONS.

RESIDENTIAL AND COMMERCIAL
MULTI-METERING INSTALLATIONS



1. Refer to SR-405, Page 2, Meter Socket and Meter Switch Identification for Company requirements.
2. Refer to SR-425 for dimensions of terminating pull sections.
3. Underground pull sections and landing lugs shall be under a separate sealable cover.
4. Refer to Local Jurisdiction Having Authority (AHJ) for main disconnect requirements. See SR-426 for Company requirements.
5. Breakers must be sealable in the off position with a Service Provider padlock/seal or individual breakers must have individual sealable covers. Pull Out fused disconnects are not allowed. 13
6. Not more than two meters shall be placed on one panel, unless all of the following specifications are met:
 - a. Cover panel can be removed without removing meters.
 - b. Only metered load conductors are accessible after the panel has been removed.
 - c. Each socket interior shall be barricaded from the other socket interiors.
 - d. Sockets must be ring-type.
7. The use of a single-phase bypass systems is required for commercial installations, refer to SR-410. It is recommended that equipment not be purchased prior to approval by Design Services.
8. For multi-meter installations, the maximum height to the centerline of any meter shall be 6'-3" and the minimum height of the centerline of any meter shall be 3'-6" if the installation is outside. For multi-meter installation only, a minimum height of 2'-6" is permitted if the installation is in a meter room or lockable enclosure. PLEASE NOTE that some four-high and most five-high meter-paks will not fit within the permitted minimum and maximum heights for outside installations, these meter-paks will not be allowed.
9. Sealing provisions must be designed to prevent cover removal without breaking seal(s).
10. Breaker and wireway covers shall be independent of meter panels unless meter-pak is designed per Note 6 of this standard.
11. A clear and level work space at least 3 feet in depth and at least as wide as the electrical equipment shall be provided and maintained in front of all electrical equipment.
12. This service installation can not be used as a means of Temporary Service. Please refer to SR-307 or SR-314 for temporary overhead and underground service installations.
13. Multi-meter services shall utilize a pull section, see SR-425 or SR-426.
14. Refer to SR-405, Page 9, for requirements for residential meter socket.
15. Each meter socket connection shall have separate home run conductors to the termination can. No tapping of conductors will be allowed within the gutter section.
16. All conductors shall be addressed and marked (taped) in accordance with SR-405. Service Provided is not responsible to 'ring out' meter to verify power path.
17. Refer to SR-410 for approved meter socket interiors and by-pass systems.
18. All commercial installations must have a single-phase by-pass system.
19. All proposed installation utilizing this standard for multi-meter installation for wireless cell facilities must utilize a single-phase bypass system and be submitted for review and approval by Company Telecommunication Design Services.

 	INITIATED BY	SC	REVISION NO.	13	SR-418 Pg. 2 of 2
	ESR COMM.	6-78	ESR COMM.	2-23	
			EFFECTIVE DATE	2-23	

USE: Multi-Family housing, four or more floors.

RESIDENTIAL, HIGH-RISE BUILDING, INDIVIDUALLY METERED UNITS



1. GENERAL

This electric service requirement details metering requirements for high-rise multi-floor residential buildings comprised of rental or owner-occupied apartment dwelling units. This standard applies to metering above ground floor and does not apply to sub-grade meter installations in parking garages and basements.

The purpose of these requirements is to provide safe, reliable service to building occupants while also accommodating Service Provider's operating and maintenance responsibilities.

2. SCOPE

High-rise buildings covered under these requirements include those consisting of multi-family housing having four or more floors above ground level with each residential dwelling unit individually metered.

3. SERVICE ENTRANCE SECTION (SES) REQUIREMENTS



- a. Standard service for high-rise residential buildings is 120/208V, three-phase, four-wire.
- b. Metering of individual dwelling units may be 120/208V single-phase or three-phase.
- c. Maximum SES size shall be 3,000 amps.
- d. Should standard 120/208V service result in excessive voltage drop or does not meet capacity needs, 277/480-volt, 3-phase, 4-wire service, may be requested.
- e. Customer is responsible for furnishing and maintaining necessary transformation to provide required voltages for individual dwelling units.
- f. Company billing meters may be installed in SES switchgear.

4. POINT-OF-DELIVERY

- a. The point-of-delivery is where Service Provider's facilities connect to Customer-owned facilities.
- b. For high-rise residential buildings, the point-of-delivery is at the secondary terminals of the Service Provider's pad-mounted distribution transformer serving the building.
- c. Customer shall own, install, operate, and maintain all wiring and equipment beyond the point-of-delivery.
- d. Service Provider will only own, read, and maintain the electrical billing meters and any associated instrument transformers beyond the point-of-delivery.

5. MAIN DISCONNECT SWITCH

- a. Customer shall furnish a main disconnect switch in the SES for the purpose of isolating all residential dwelling unit billing meters from the Company supply.
- b. Main disconnect switch shall be load-break, have a rating equal to the bus duct riser rating, and be lockable in the open position.
- c. Main disconnect switch may be installed between the Service Provider's distribution transformer and the SES or may be installed in a dedicated compartment in the SES.

		INITIATED BY	EKD	REVISION NO.	0	SR-419 Pg. 1 of 4
		ESR COMM.	11-21	ESR COMM.	-	
		ESR COMM.	11-21	EFFECTIVE DATE	11-21	

USE: Multi-Family housing, four or more floors.

RESIDENTIAL, HIGH-RISE BUILDING, INDIVIDUALLY METERED UNITS



6. METER ROOM LOCATION & METERING



- a. Meters for all dwelling units shall be grouped in meter packs and located in locked meter rooms, refer to SR-405. All metering equipment shall be located on ground level for buildings with less than four floors.
- b. Maximum height to center of meter socket is 6'-3" minimum height shall be 3'-6", except for multi-meter packs for which the minimum height is permitted to be 2'-6".
- c. There shall be no more than one electrical meter room for every two floors.
- d. Each meter room shall be located within 50 feet of an elevator.
- e. Meter rooms shall be located in approximately the same location on each floor.
- f. Meter rooms shall have adequate space for installation, reading, and maintenance of metering equipment.
- g. Meter rooms shall not be used for any type of storage.
- h. Fire risers and water valves are not allowed in meter rooms.
- i. Fire sprinkler heads shall not be directly above meter panel equipment.
- j. Customer shall provide a 1 inch metal conduit from each above ground level switchgear/meter room to an exterior junction box located at ground level for Company installation of metering antennas.

7. ACCESS

- a. Service Provider's access to any locked electrical meter rooms shall be by means of a lock box, refer to SR-405, Definitions, Meter Room.
- b. A pushbutton wall-mounted key lock box will be provided to the Customer for installation to provide unrestricted access for Service Provider's personnel.
- c. The lock box shall be with 12 inches of the locked door and shall contain the key.
- d. The customer shall provide a key(s) to the Service Provider prior to energizing of meter equipment. It is the responsibility of the customer to ensure that if a door lock is changed a new key is provided to the Company.
- e. The customer is to ensure that any locking mechanism on a meter room door(s) is in compliance with any Federal or State Fire Code Requirements.

8. LABELING

- a. Meter sockets for dwelling units shall be clearly labeled with each unit's number, refer to SR-405.
- b. A building diagram shall be permanently posted on the SES pull section cover listing all meter locations and associated dwelling units.

		INITIATED BY	EKD	REVISION NO.	0	SR-419 Pg. 2 of 4
		ESR COMM.	11-21	ESR COMM.	-	
		ESR COMM.	11-21	EFFECTIVE DATE	11-21	

USE: Multi-Family housing, four or more floors.

RESIDENTIAL, HIGH-RISE BUILDING, INDIVIDUALLY METERED UNITS





9. SEALING OF UN-METERED CONDUCTORS

- a. Means shall be provided to seal the main disconnect switch and any SES compartments housing circuit breakers or fused switches that serve as the disconnecting means for the dwelling unit meter packs. Those sealing means shall be capable of accommodating a standard Service Provider meter lock.
- b. Means shall be provided to seal any box or conductor raceway containing un-metered conductors with a Service Provider meter lock, in the same manner as that described for the SES.

10. CONNECTION FROM SES TO METER PACKS

- a. Connection from each disconnecting means in the SES to each meter pack shall be made by metal-enclosed bus duct.
- b. Bus duct shall be designed to allow for a close-coupled connection with each meter pack.
- c. Installation of all bus duct, dwelling unit meter packs, and associated connections must be completed to all floors before Service Provider will energize the SES.
- d. See FIGURE 1 for a typical one-line diagram for high-rise residential building metering.

		INITIATED BY	EKD	REVISION NO.	0	SR-419 Pg. 3 of 4
		ESR COMM.	11-21	ESR COMM.	-	

USE: Multi-Family housing, four or more floors.

RESIDENTIAL, HIGH-RISE BUILDING, INDIVIDUALLY METERED UNITS

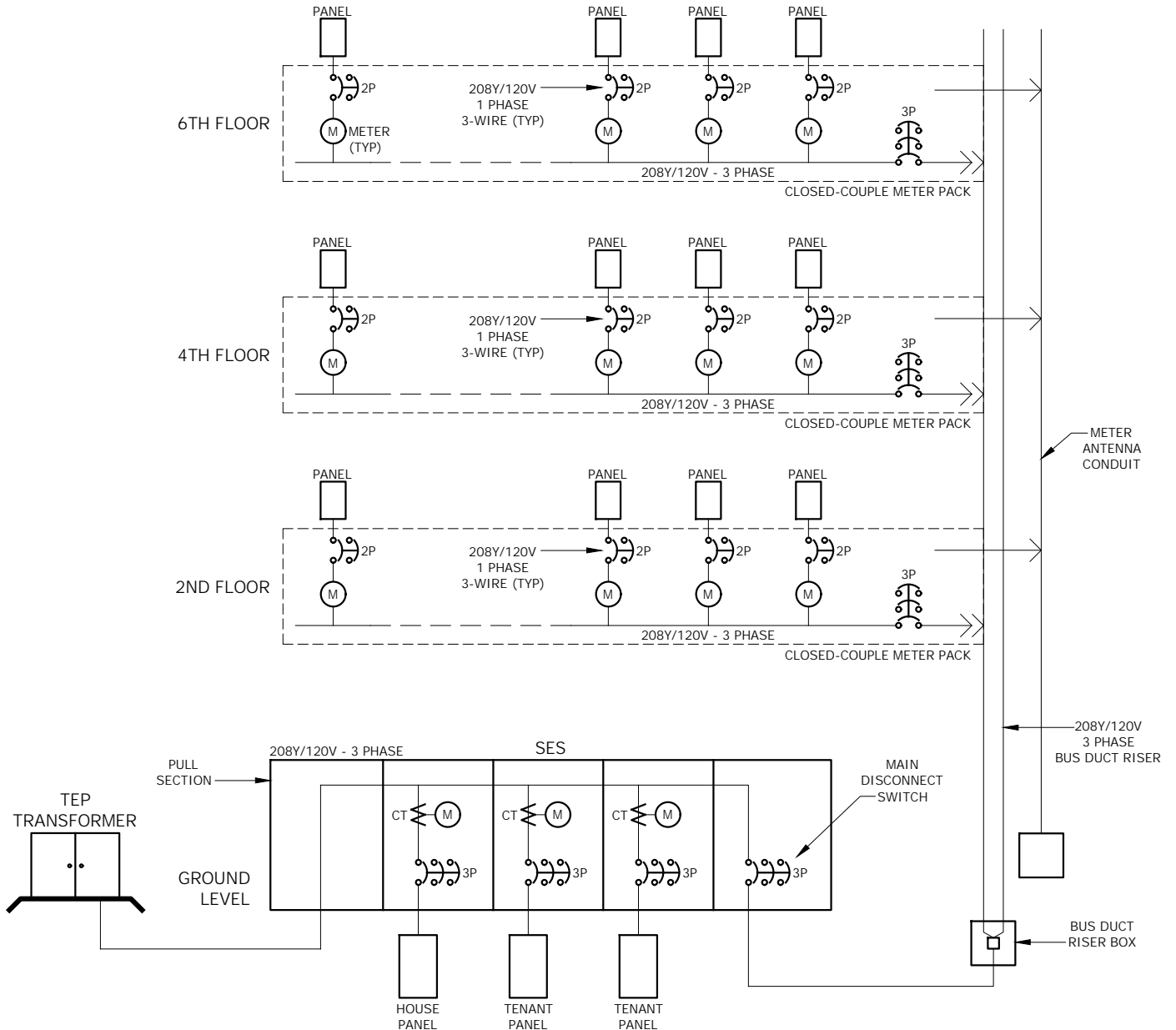
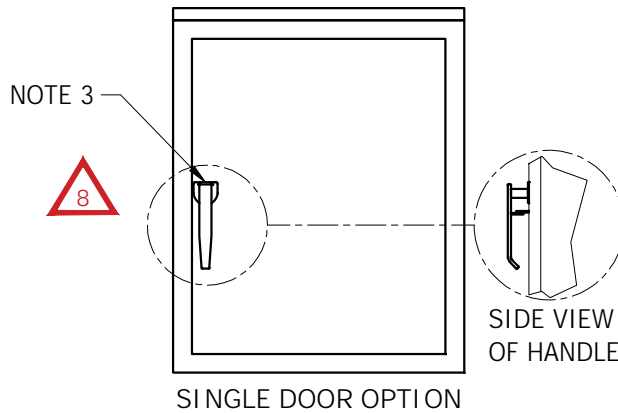
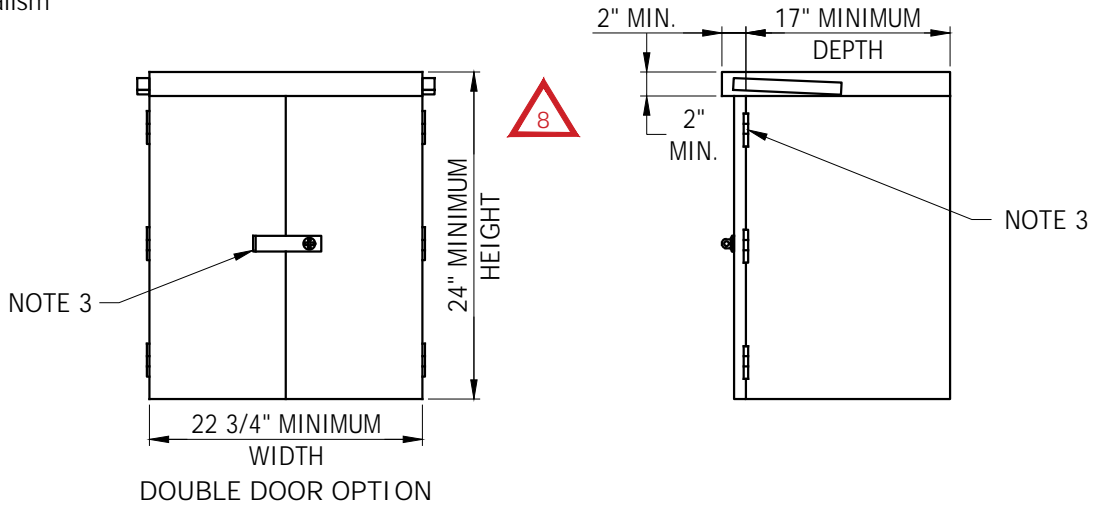

FIGURE 1
TYPICAL METERING ONE-LINE DIAGRAM

USE: Protect Company
Equipment from
Vandalism

EQUIPMENT ENCLOSURE CABINETS



NOTES:

1. CUSTOMER SHALL INSTALL CABINET AT THE REQUEST OF SERVICE PROVIDER FOR PROTECTION OF COMPANY EQUIPMENT. FOR SERVICE METER PANELS INSTALLED IN PUBLIC ROW OR COMMON PUBLIC AREAS, INSTALL PER SR-409.
2. EQUIPMENT ENCLOSURE CABINETS SHALL BE CONSTRUCTED OF STEEL OF NOT LESS THAN NO. 16 MSG, PROTECTED AGAINST CORROSION BOTH INSIDE AND OUTSIDE. THEY SHALL SHED WATER, BUT ARE NOT REQUIRED TO BE RAIN-TIGHT.
3. EQUIPMENT ENCLOSURE CABINET DOORS SHALL BE HINGED AND PROVIDED WITH A LATCHING DEVICE THAT WILL ACCOMMODATE A SERVICE PROVIDER PADLOCK. HINGES SHALL BE ON THE SIDES SO THAT MAXIMUM WORKING SPACE IS AVAILABLE. SINGLE OR DOUBLE DOORS ARE APPROVED.
4. NOT SUITABLE FOR METER POSTS (SR-408, PG. 5), SAFETY SOCKET BOX (SR-410, 480V INSTALLATIONS). CONSULT DESIGN SERVICES FOR INSTALLATION OF THESE DEVICES.
5. SUGGESTED PART NUMBERS & MANUFACTURERS:

P/N: EP222415
T. A. CAID & SONS
GENERAL SHEET METAL
2049 W. HIGHWAY DRIVE
TUCSON, AZ 85705



P/N: 514U7946
METER DEVICES CO., INC.
BROOKS UTILITY PRODUCTS
43045 W. NINE MILE ROAD
NOVI, MI 48375

USE: CURRENT TRANSFORMER
INSTALLATIONS, 0-600V,
SINGLE CUSTOMER (NOT
IN SWITCHGEAR).

CURRENT TRANSFORMER INSTALLATIONS IN CABINETS

EUSERC DWG. NO. 317
*(SEE NOTE 1) 318
328A
328B
329A
329B

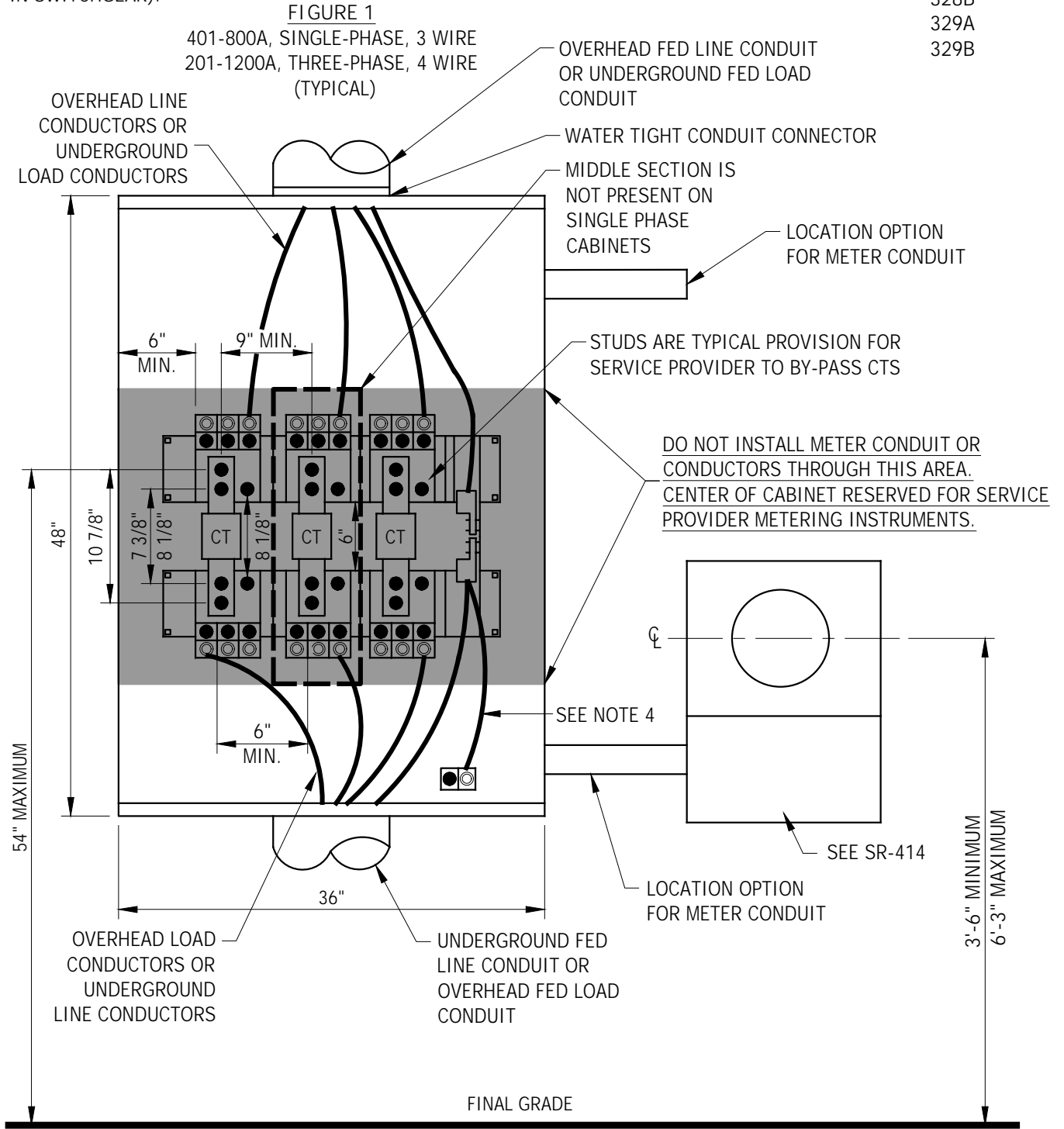

NOTES:

- *ERICKSON CABINET DIMENSIONS ARE DIFFERENT THAN EUSERC, BUT ARE APPROVED. SEE PAGE 5, ITEM 7 FOR APPROVED MANUFACTURERS.
- ALL SERVICE CONDUIT SHALL BE IMC OR RMC FROM CT CABINET TO A MINIMUM OF 18" BELOW FINAL GRADE.
- CONDUIT AT COMPANY PAD-MOUNT TRANSFORMER OR SECONDARY JUNCTION BOX SHALL BE GREY PVC ELECTRICAL GRADE, SCHEDULE 40.

		INITIATED BY	SC	REVISION NO.	10	SR-422
		ESR COMM.	2-80	ESR COMM.	8-20	
				EFFECTIVE DATE	8-20	Pg. 1 of 5

USE: CURRENT TRANSFORMER
INSTALLATIONS, 0-600V,
SINGLE CUSTOMER (NOT
IN SWITCHGEAR).

CURRENT TRANSFORMER INSTALLATIONS IN CABINETS

EUSERC DWG. NO. 322
330



FIGURE 2
1201-2000A

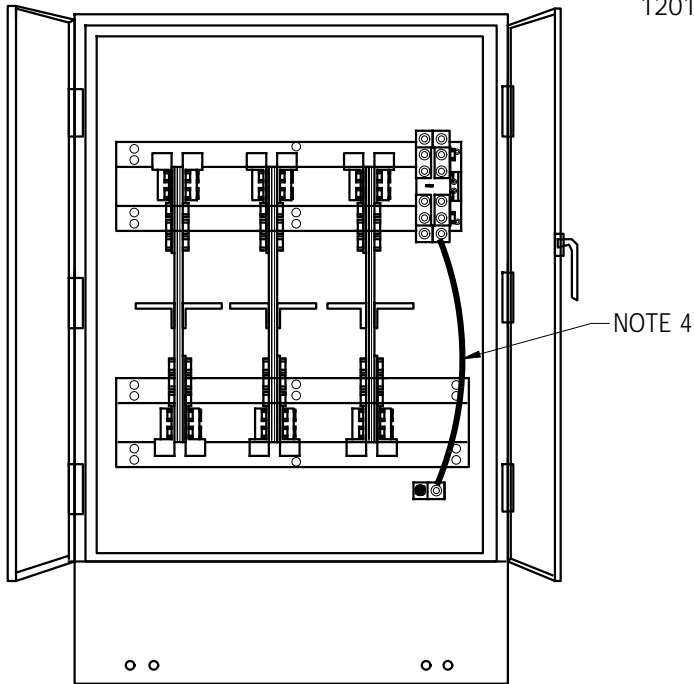

SEE SR-422, PAGE 2 OF 5, FOR
FURTHER INSTALLATION NOTES

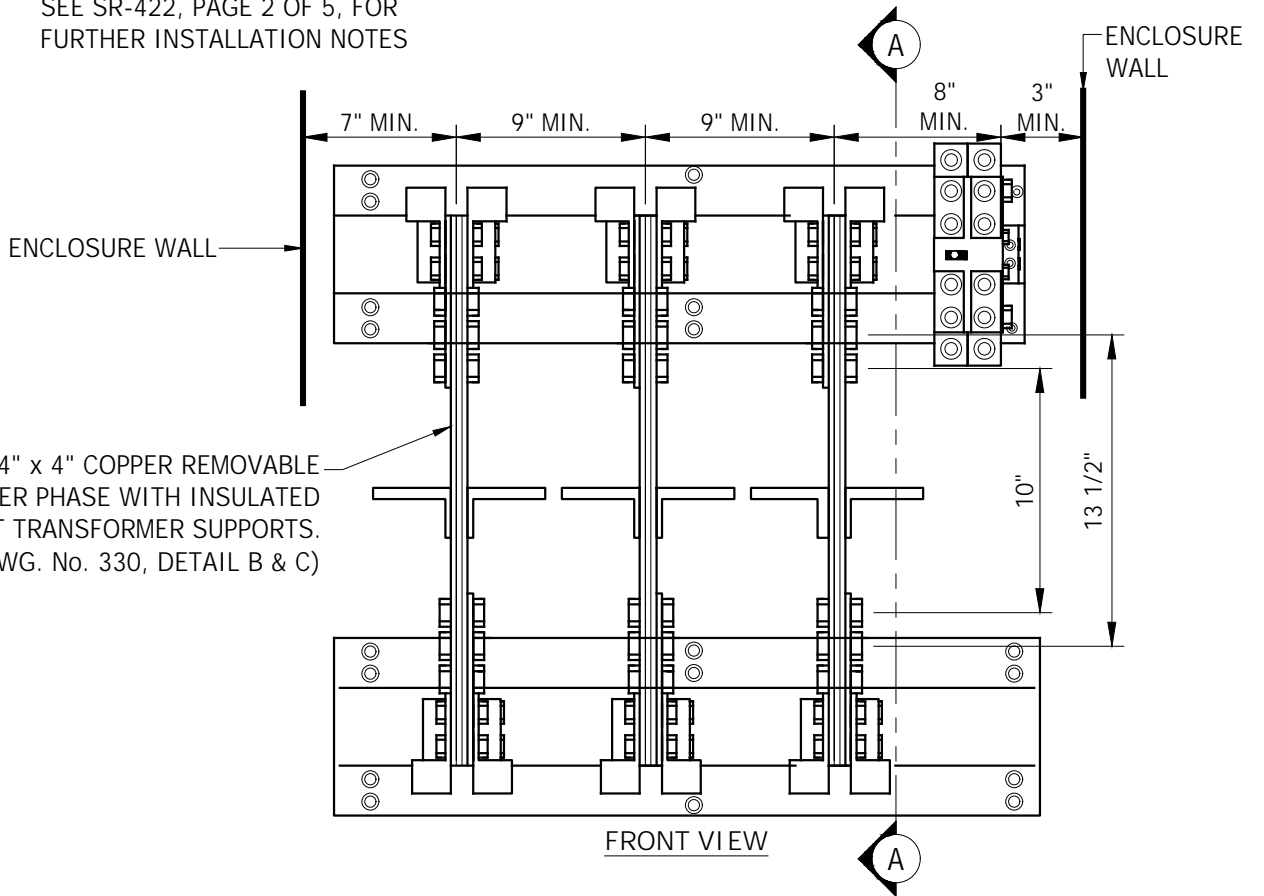
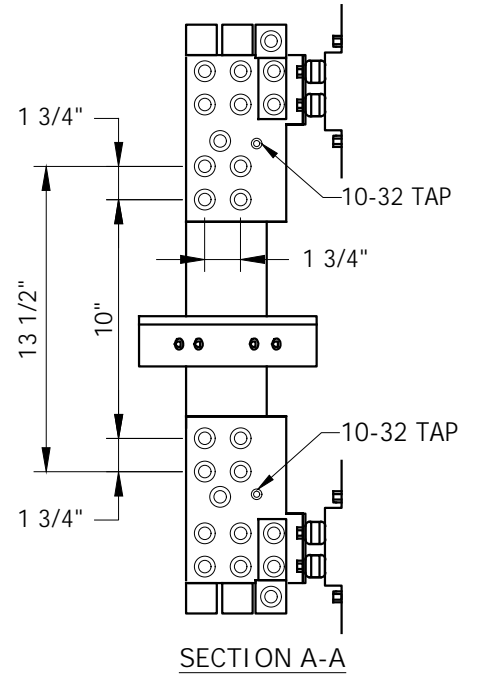

		INITIATED BY	SC	REVISION NO.	13	SR-422	
		ESR COMM.	2-80	ESR COMM.	8-20		Pg. 2 of 5
				EFFECTIVE DATE	8-20		

USE: CURRENT TRANSFORMER
INSTALLATIONS, 0-600V,
SINGLE CUSTOMER (NOT
IN SWITCHGEAR).

CURRENT TRANSFORMER INSTALLATIONS IN CABINETS



1. APPLICABLE LOADS AND VOLTAGES

Cabinets with Current Transformer (CT or CTs) mounting bases may be used with service entrance sizes and voltages as follows:

- a. 120/240V, Single-Phase, 3 wire, 401-800 Amp, Two CTs
- b. 240/120V, Three-Phase, 4 wire, Delta, 201-1200 Amp, Three CTs, NOT for new installation
- c. 208Y/120V, Three-Phase, 4 wire, Wye, 201-2000 Amp, Three CTs
- d. 480Y/277V, Three-Phase, 4 wire, Wye, 201-2000 Amp, Three CTs

Consult Design Services regarding proposed installations for any other load and voltage. See SR-104 for service limitations.

2. GENERAL PROCEDURE

The customer provides and installs a CT cabinet containing a mounting base for the required number of CTs, line and/or load conductors required for the type service entrance utilized, the meter socket(s) and a conduit between the CT cabinet and the meter socket(s).



The CT cabinet is for terminating line and load conductors, and installation of metering CTs. This is for the specific customer that requires transformer rated metering only and can not be utilized as a termination cabinet, or tapping point for other customers line conductors.

Following the Service Provider's inspection and approval of the customer's installation, the Service Provider furnishes and installs the CTs, necessary metering conductors from the CTs to the meter socket(s), sets the meter(s) and connects the customer's service entrance equipment to the distribution system.

3. CABINET REQUIREMENTS

A metallic cabinet complete with the required CT mounting base as described herein shall be furnished and installed by the customer. The cabinet shall be raintight and protected against corrosion on inside and outside surfaces. Only CT cabinets approved by and meeting Service Provider's specifications may be installed.

The CT mounting base shall be rated by the manufacturer for the maximum continuous load rating of the main switch(s) or breaker(s) in the service entrance. If the line side conductors enter the bottom of the cabinet, the load side conductors shall exit in the top or upper sides. If the line side conductors enter the top of the cabinet, the load side shall exit the bottom or lower sides. No conductors shall be allowed to pass through the center of the CT cabinet. Meter conduit shall not be installed in the area of the CT cabinet reserved for use by the Service Provider for installation of CTs.

		INITIATED BY	GS	REVISION NO.	5	SR-422 
		ESR COMM.	3-90	ESR COMM.	8-20	
				EFFECTIVE DATE	8-20	Pg. 3 of 5

USE: CURRENT TRANSFORMER
INSTALLATIONS, 0-600V,
SINGLE CUSTOMER (NOT
IN SWITCHGEAR).

CURRENT TRANSFORMER INSTALLATION IN CABINET



CABINET REQUIREMENTS (CONT'D)

FIGURE 1

CTs are supported by their bars on four (4) mounting studs which are positioned in the bus on the mounting base with spacing exactly as shown. The CT mounting studs shall be a maximum of 1/2 inch diameter and a minimum of 3/8 inch diameter. Flat washers, pressure-maintaining spring washers and nuts as required shall be furnished by the customer.

CT mounting studs shall be firmly affixed to the bus on the mounting base so that they will not turn, back out or loosen when subjected to torques approved by UL for tightening or loosening of nuts on bolts of that size (including cross-threaded situations). The studs shall be fully threaded, except for the portion within 3/8 inch of the bus on the mounting base, and they shall be long enough to be threaded completely through the nut when a CT with a bar 1/2 inch thick is mounted with washers.

A provision to connect a bypass capable of carrying the full rated load of the service entrance shall be provided for each CT position on the mounting base.

FIGURE 2

Bus anchorage shall be such that busses will remain in position when removable copper links are out. Bus corners should be rounded as necessary to prevent damage to insulation. Bus insulation is to be adequate for the voltage involved. The maximum permissible bus unit shall consist of four 1/4" x 4" bars spaced 1/4 inch.

FIGURES 1 AND 2



Cabinet covers shall be provided with a means of sealing consisting of two drilled studs and wing nut assemblies on opposite sides. All securing screws shall be captive. If the cabinet cover is not hinged, two lifting handles shall be provided on any cover having a surface area of four or more square feet. Hinged doors may be provided with a latching device that will accommodate a Company padlock.

4. CABINET INSTALLATION

The location of the cabinet shall conform to the requirements of SR-405. The neutral connector shall be bonded to the CT cabinet.

4a. OVERHEAD SINGLE OR THREE-PHASE SERVICE

The point of delivery shall be at the point of attachment for the overhead service. Connectors are furnished and installed by the Service Provider. The customer's conductors between the point of delivery of the service and the CT cabinet shall pass through no other equipment. The "neutral" (and the "power leg", if delta-connected 240/120V service is furnished) shall be identified per the National Electrical Code. If conductors are parallel, they shall be grouped and identified at the point of delivery. If more than one raceway of magnetic metal conduit is used for parallel conductors, one conductor from each phase, plus one neutral conductor, must pass through each conduit.

		INITIATED BY	SC	REVISION NO.	7	SR-422 
		ESR COMM.	2-80	ESR COMM.	8-20	
				EFFECTIVE DATE	8-20	

USE: CURRENT TRANSFORMER
INSTALLATIONS, 0-600V,
SINGLE CUSTOMER (NOT
IN SWITCHGEAR).

CURRENT TRANSFORMER INSTALLATIONS IN CABINETS



4b. UNDERGROUND SINGLE-PHASE SERVICE

The point of delivery shall be at the junction of the Company's service conductors and the customer's connectors at the bottom of the current transformer mounting base. These connectors shall accommodate 750kcmil concentric stranded conductor and shall be suitable for terminating copper or aluminum. They shall have two 1/2 inch holes per tang, or be of a design that will prevent them from turning on the bus. Double barrel connectors and two service ducts required if paralleled service cables are specified by Design Services.

Four (4) inch Schedule 40 PVC and Intermediate Metal Conduit (IMC) or Rigid Metal Conduit (RMC) shall be furnished and installed by the customer. At the riser pole and/or CT cabinet the sweep and riser shall be IMC or RMC. The mainline conduit run below grade from the pad-mount transformer or riser pole to the current transformer cabinet shall be Schedule 40 PVC. The distance from the bottom of the cabinet to the bottom of the connectors on the lower portion of the CT mounting base shall be at least 16 inches. The space between the CT mounting base and the riser pipe entering the bottom of the cabinet is required by the Service Provider for installation and termination of service conductors. It shall be kept clear of customer's conductors or other obstructions.

4c. UNDERGROUND THREE-PHASE SERVICE

The point of delivery shall be at a secondary junction box or at a pad-mount transformer or at some other point as may be designated by Design Services. The customer's conductors between the point of delivery of the service and the CT cabinet shall pass through no other equipment. The "neutral" (and the "power leg" if delta-connected 240/120V service is furnished) shall be identified per the National Electrical Code. All service conductors shall be marked (taped) in accordance with SR-405 Note 16. If conductors are parallel, they shall be grouped and identified at the point of delivery. If more than one raceway of magnetic metal conduit is used for parallel conductors, one conductor from each phase plus one neutral conductor must pass through each conduit. The neutral of each set of service conductors must be identified with an address tag at the transformer or junction box location. Example: Dymo Aluminum embossing tape or other approved methods. Customer conductors that connect to Service Provider equipment shall be no greater than 600kcmil.

5. METERING CONDUIT AND METER SOCKET INSTALLATION

The metering conduit shall be installed by the customer between the CT cabinet and the kWh meter socket in accordance with SR-414. It shall be constructed of intermediate metal or rigid metal conduit and fittings. The meter socket(s) shall be installed by the customer in accordance with the requirements of SR-400 Service Requirements, and located as close to the CT cabinet as is reasonable. The customer must furnish and install a meter enclosure cabinet per SR-420 if the meters are located in a park, schoolyard, or other area subject to vandalism or for meter totalizing.

Unused hubs shall be capped off with a rainproof access plate(s) that is secured internally utilizing a carriage bolt and a wingnut bar that spans beyond the opening. See SR-405.

6. LINE AND LOAD CONDUCTOR CONDUIT

Conduit entering and exiting the CT cabinet for line and load conductors shall be IMC or RMC.

7. APPROVED MANUFACTURERS OF CT CABINETS

Erickson Electrical Equipment Co. 1-800-952-7225

FIGURE 1 Single-Phase 800A - Catalog No. 1076-1
Three-Phase 1200A - Catalog No. 1076-2

FIGURE 2 Three-Phase 1200A - Catalog No. CT124-TEP
Three-Phase 1600A - Catalog No. CT164-TEP
Three-Phase 2000A - Catalog No. CT204-TEP



Brooks Utility Products 1-888-687-3008

FIGURE 1 Single-Phase 800A - Catalog No. 564-9338
Three-Phase 1200A - Catalog No. 564-9338

		INITIATED BY	SC	REVISION NO.	13	SR-422 Pg. 5 of 5
		ESR COMM.	2-80	ESR COMM.	3-22	
				EFFECTIVE DATE	3-22	

USE: Metering single customer on pad-mount primary metered equipment using CT's & PT's.

METER SOCKET AND CONDUIT INSTALLATION DETAIL FOR PRIMARY METERED SERVICE IN A PAD-MOUNT 200A OR LESS

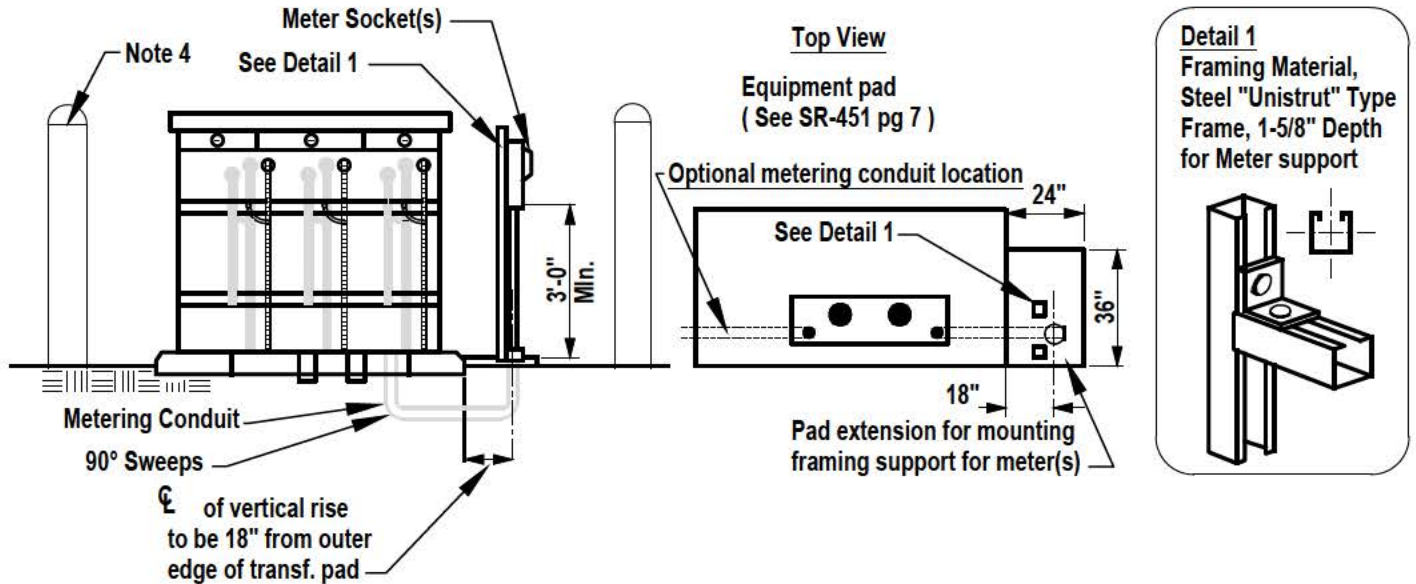

NOTES:

1. **Applicable Voltage and Loads** - 13.8 kv three phase, four wire grounded wye. 200 amperes or less. Consult the area Designer for the specific applicability.
2. **General Procedure** - The point of delivery is at the CT's, furnished by the company. The customer provides and installs the equipment pad, terminating UG primary cable (customer owned), metering conduit, meter socket and equipment protection (if required). The company installs the CT's / PT's (current and potential transformers) mounted within the cabinet, wires the metering conductors and sets the meter. The company attaches the load-break elbow to the CT's.
3. **Metering Conduit and Meter Socket Installation** - Installation of the metering conduit and meter socket(s) shall meet the requirements of SR-414. The metering conduit (min. 1-1/4") shall be Schedule 40 PVC (or Schedule 80 PVC) from primary metering cabinet opening to the buried portion of the conduit. The above-grade portion must be rigid or intermediate steel conduit. All PVC shall be rated 90 C operation. The riser primary metering compartment shall extend 2" above the top of the concrete pad and the open end of this conduit shall be sealed to prevent entry of debris prior to installation of metering conductors. Any metering conduit extending more than two feet outside the concrete pad shall be 18" below final grade and be covered with 4" of concrete. If the metering conduit is ever dug up or damaged, it shall be the customer's responsibility to replace it according to company specifications.

The meter socket must be mounted securely on a supporting frame, constructed of rigid steel framing material, "Unistrut" type that is set in concrete adjacent to and adjoining the equipment pad. The customer must furnish and install a meter enclosure cabinet per SR-420 if the meter(s) are located in a park, schoolyard, or other area subject to vandalism, or for meter totalizing.

4. **Protection of Transformer and Metering Equipment from Traffic Hazards** - Where transformer and metering equipment are exposed to vehicular traffic, approved traffic protection must be installed around the equipment. (See SR-230.)

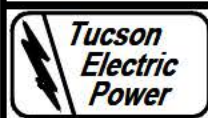

INITIATED BY	SC
STANDARDS COMM.	5-75

REVISION NO.	10
STANDARDS COMM.	1-03
EFFECTIVE DATE	1-03

REVISION NO.	10
STANDARDS COMM.	1-03
EFFECTIVE DATE	1-03

SR-423
Pg. 1 of 1

DETAIL FOR PRIMARY METERED SERVICE IN A REMOTE METERING CABINET 201A - 800A

General Notes

1. A separate metering enclosure shall be installed near the Primary Dead End structure, underground equipment cabinet, or as indicated on the TEP Construction drawing.
2. Conduit for the metering wiring from the current and potential transformers (Junction Box/Safety Switch to the meter enclosure) shall enter the meter enclosure through the bottom and shall be installed behind the hinged meter panel. Conduit shall not interfere with the operation of the test switches or the hinged meter panel. The metering conduit shall not have more than three 90 degree bends or sweeps and shall not exceed 120ft in maximum length for lengths up to 90ft, conduit must be a minimum of 1 1/4" in diameter, and for lengths over 90ft up to 120ft conduit must be a minimum of 2" in diameter. A pull wire must be installed in conduit. Accessible and sealable pulling junctions are allowable if needed.
3. A CT junction box(es) rated NEMA 4X enclosures sized 12"x12"x6" with a back panel shall be installed near the instrument transformers. The junction box for the CT's shall be installed on the steel structure that the CT's are mounted. Conduit from the CT's shall run to the junction box and from the junction box to the metering enclosure. The enclosures shall have a latching system that will allow padlocking and the installation of metering seals. Each enclosure shall have a stainless steel identification plate mechanically fastened to the door. The plate shall have one line of text. Line 1 shall read "TEP METERING" in block lettering.
4. A three-phase safety switch shall be installed on the 120V side (secondary) of each set (3) of PT's. The safety switch shall have a ground bus included for connection of the X2 connections. Conduit from the PT's shall run to the safety switch and from the safety switch to the metering enclosure.

Safety Switch Specification for PT secondary

Square D Heavy Duty Safety Switch, 240V, fusible, Cat #H221DS (30A, 2 wire - 2 blades and fuseholders, NEMA 4, 304 Stainless Steel) or Cat #H321DS (30A, 3 wire - 3 blades and fuseholders, NEMA 4, 304 Stainless Steel). With a Neutral Assembly Cat #SN03 and a ground kit Cat #GTK03.

Safety Switch watertight hubs (one for the top and/or one for the bottom) for the conduit size required:

Conduit	
Size	Cat #
1/2"	H050
3/4"	H075
1" H100	
1 1/4"	H125

5. New metering enclosures and equipment shall be installed as per TEP standard SR-431, and SR-430. The metering enclosure shall be constructed as per SR-438 (Figure 2, EUSERC DWG 333) and EUSERC DWG 338. Enclosure to contain two (2) form 9S meter sockets, two (2) Removable "I" Plates and two (2) test switches. Test switches shall be Milbank Cat # TS10-0016 and cover Milbank Cat # K3388-BLK-FL as per TEP standards SR-430 note 5 or exact equivalent must be provided. Meter sockets shall be 13 terminal sockets. The door of the enclosure shall have a three point padlockable door latch mechanism to hold the door closed and to lock it closed. The enclosure will have four (4) 4" tabs welded to the enclosure for mounting purposes. The tabs will be welded to the outside back of the enclosure. Two (2) tabs will be mounted at the top and two (2) mounted to the bottom of the enclosure. Enclosure shall have a stainless steel identification plate mechanically fastened to the door. The plate shall have one line of text. Line 1 shall read "TEP METERING" in 2" tall block lettering.
6. A conduit shall be installed between all metering panel enclosures to allow for meter communications wiring. The minimum conduit size shall be 1".
7. A dedicated telephone circuit shall be provided for TEP metering usage. The telephone wiring shall be installed in a minimum conduit size of 1" to the metering panel enclosure. Cat 3 cable shall be used for the telephone circuit.
8. All raceway installations shall be made with rigid steel conduit. For underground installations the raceway shall be rigid steel PVC coated conduit.
9. Customer shall provide a dedicated phone circuit to be utilized by TEP Metering to allow communications with the Metering Equipment.

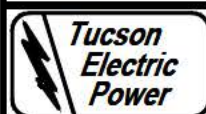

INITIATED BY

GC

REVISION NO.

0

ESRB COMM.

6-06

STANDARDS COMM.

7-06

EFFECTIVE DATE

7-06

SR-424
Pg. 2 of 2

USE: Termination of underground service to single & three-phase multi-meter installations.

TERMINATING BOX OR SECTION



NOTES:

1. The pull section cover shall be independent of any service equipment other than the pull section. Provision for sealing shall be made near opposite corners of the cover. The securing screws shall be captive, and lifting handles shall be provided if the cover is more than four square feet in area.
2. Terminal connectors on the line side shall be of proper material and size to accommodate copper or aluminum conductors as specified by the Service Provider.
3. Except where lay-in type connectors are permitted, the terminal connectors shall be removable to facilitate cable installation. Bolts used to secure the terminal connectors to the bus stubs shall be 3/8 inch minimum diameter and shall be firmly affixed to the bus stubs in such a manner that they will not turn, back out, or loosen when subjected to normal UL approved torques for that size bolt during tightening or loosening of terminal nuts (including cross-threaded situations). Mechanical connectors shall be attached to the bus stubs, using flat washers, pressure maintaining spring washers and nuts, and the bolts shall be long enough to be threaded completely through the nuts. All parts must be plated to prevent corrosion.

Lay-in type connectors are permitted for connectors with a range of 1/0 AWG - 250 KCMIL and 1/0 AWG - 350 KCMIL.



Connectors with a range of 350 KCMIL - 750 KCMIL shall have two 1/2 inch holes per tang, or be of a design that will prevent them from turning on the bus stub

4. Bus stubs shall be anchored to prevent turning. A minimum radial clearance of 1 1/2 inches shall be provided between hot bus terminals and grounded or neutral surfaces.
5. The customer must provide and install a 2 1/2 inch or 4 inch continuous duct system, in accordance with SR-205, from the terminating box to the point of delivery as specified by the Service Provider.

All continuous duct runs, regardless of size, are to have a 90 degree sweep with a 36 inch radius at the service riser and are not to exceed 270 degree for a total of all deflections.

The conduit riser to the terminating box shall be rigid or intermediate steel (IMC or RMC) conduit, even if the box is enclosed within a structure. Schedule 80 PVC is not acceptable.

6. All service conductors shall be marked (taped) in accordance with SR-405, Note 16.
7. Neutral connector shall be bonded to the enclosure.
8. See Service Provider construction drawing for size and number of conduits. Double barrel connectors and two service ducts are required if paralleled service cables are required and specified by Design Services.

		INITIATED BY	SC	REVISION NO.	7	SR-425 
		ESR COMM.	8-78	ESR COMM.	2-24	
				EFFECTIVE DATE	2-24	Pg. 1 of 2

USE: Termination of underground service to single & three-phase multi-meter installations.

TERMINATING BOX OR SECTION

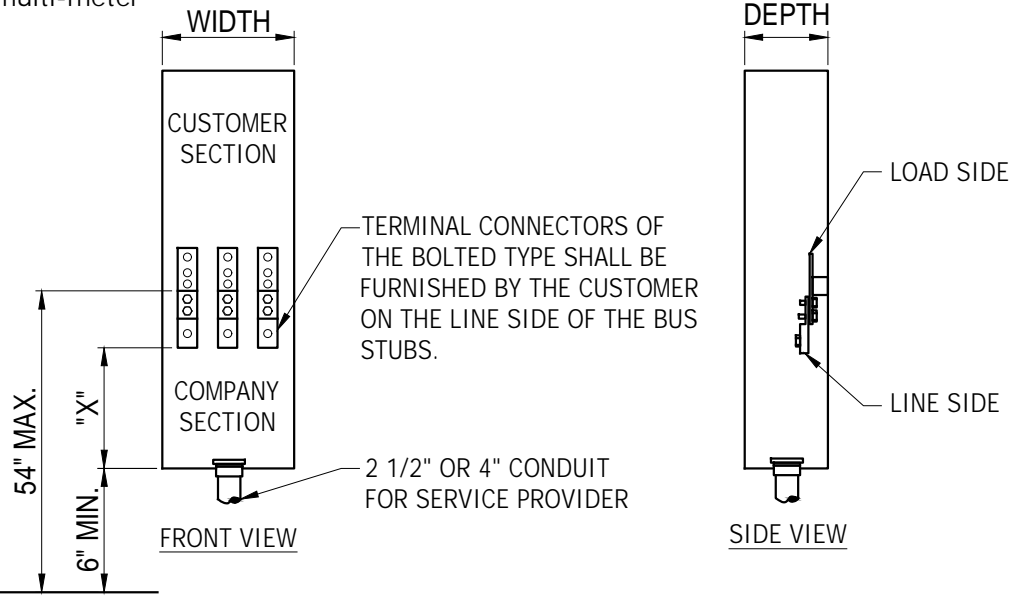

MULTIPLE OCCUPANCY RESIDENTIAL UNITS, 100-125A METER SOCKETS

NUMBER OF METER SOCKETS	SERVICE ENTRANCE AMPACITY	CONNECTOR RANGE SEE NOTES 9 & 10	MINIMUM DIMENSION (IN INCHES)			CONDUIT SIZE (IN INCHES) SEE NOTE 4
			WIDTH	DEPTH	"X"	
2 THRU 3	200	1/0 AWG - 250 KCMIL	7	4 1/2	11	2 1/2
4 THRU 10	400-800	1/0 AWG - 350 KCMIL	7	4 1/2	11	2 1/2
OVER 10	CONSULT DESIGN SERVICES					

MULTIPLE OCCUPANCY RESIDENTIAL UNITS, 200A METER SOCKETS

NUMBER OF METER SOCKETS	SERVICE ENTRANCE AMPACITY	CONNECTOR RANGE SEE NOTES 9 & 10	MINIMUM DIMENSION (IN INCHES)			CONDUIT SIZE (IN INCHES) SEE NOTE 4
			WIDTH	DEPTH	"X"	
2 THRU 3	400	1/0 AWG - 350 KCMIL	7	4 1/2	11	2 1/2
OVER 3	CONSULT DESIGN SERVICES					

MULTIPLE OCCUPANCY COMMERCIAL UNITS, 100A-125A METER SOCKETS

NUMBER OF METER SOCKETS	SERVICE ENTRANCE AMPACITY	CONNECTOR RANGE SEE NOTES 9 & 10	MINIMUM DIMENSION (IN INCHES)			CONDUIT SIZE (IN INCHES) SEE NOTE 4
			WIDTH	DEPTH	"X"	
2 THRU 3	200-300	1/0 AWG - 350 KCMIL	7	4 1/2	11	2 1/2
4 THRU 6	400-600	350 KCMIL - 750 KCMIL	10	6	16	4

MULTIPLE OCCUPANCY COMMERCIAL UNITS, 200A METER SOCKETS

NUMBER OF METER SOCKETS	SERVICE ENTRANCE AMPACITY	CONNECTOR RANGE SEE NOTES 9 & 10	MINIMUM DIMENSION (IN INCHES)			CONDUIT SIZE (IN INCHES) SEE NOTE 4
			WIDTH	DEPTH	"X"	
2 THRU 4	400-600	350 KCMIL - 750 KCMIL	10	6	16	4

USE: Termination of underground service to single & three-phase multi-meter installations.

COMBINATION TERMINATING BOX AND MAIN DISCONNECT



NOTES:

1. The pull section cover shall be independent of any service equipment other than the pull section, including the breaker access cover. Provision for sealing shall be made near opposite corners of the cover. The securing screws shall be captive, the cover shall be one piece, and lifting handles shall be provided if the cover is more than four square feet in area.
2. Terminal connectors on the line side shall be of proper material and size to accommodate copper or aluminum conductors as specified by the Service Provider and shall be located in a sealable area.
3. Except where lay-in type connectors are permitted, the terminal connectors shall be removable to facilitate cable installation. Bolts used to secure the terminal connectors to the bus stubs shall be 3/8 inch minimum diameter and shall be firmly affixed to the bus stubs in such a manner that they will not turn, back out, or loosen when subjected to normal UL approved torques for that size bolt during tightening or loosening of terminal nuts (including cross-threaded situations). Mechanical connectors shall be attached to the bus stubs, using flat washers, pressure maintaining spring washers and nuts, and the bolts shall be long enough to be threaded completely through the nuts. All parts must be plated to prevent corrosion.

Lay-in type connectors are permitted for connectors with a range of 1/0 AWG - 250 KCMIL and 1/0 AWG - 350 KCMIL.



Connectors with a range of 350 KCMIL - 750 KCMIL shall have two 1/2 inch holes per tang, or be of a design that will prevent them from turning on the bus stub.

4. Bus stubs shall be anchored to prevent turning. A minimum radial clearance of 1 1/2 inches shall be provided between hot bus terminals and grounded or neutral surfaces.
5. Neutral connector shall be bonded to the enclosure.
6. The customer must provide and install a 2 1/2 inch or 4 inch continuous duct system, in accordance with SR-205, from the terminating box to the point of delivery, as specified by the Service Provider.

All continuous duct runs, regardless of size, are to have a 90 degree sweep with a 36 inch radius at the service riser and are not to exceed 270 degree for a total of all deflections.

The conduit riser to the terminating box shall be rigid or intermediate steel (IMC or RMC) conduit, even if the box is enclosed within a structure. Schedule 80 PVC is not acceptable. Service riser shall be centered (front to back) under pull area, not under breaker area.

5. All service conductors shall be marked (taped) in accordance with SR-405, Note 16.
6. Neutral connector shall be bonded to the enclosure.
7. See Service Provider construction drawing for size and number of conduits. Double barrel connectors and two service ducts are required if paralleled service cables are required and specified by Design Services.

		INITIATED BY	SC	REVISION NO.	5	SR-426  Pg. 1 of 2
		ESR COMM.	1-80	ESR COMM.	2-24	
				EFFECTIVE DATE	2-24	

USE: Termination of underground service to single & three-phase multi-meter installations.

COMBINATION TERMINATING BOX AND MAIN DISCONNECT

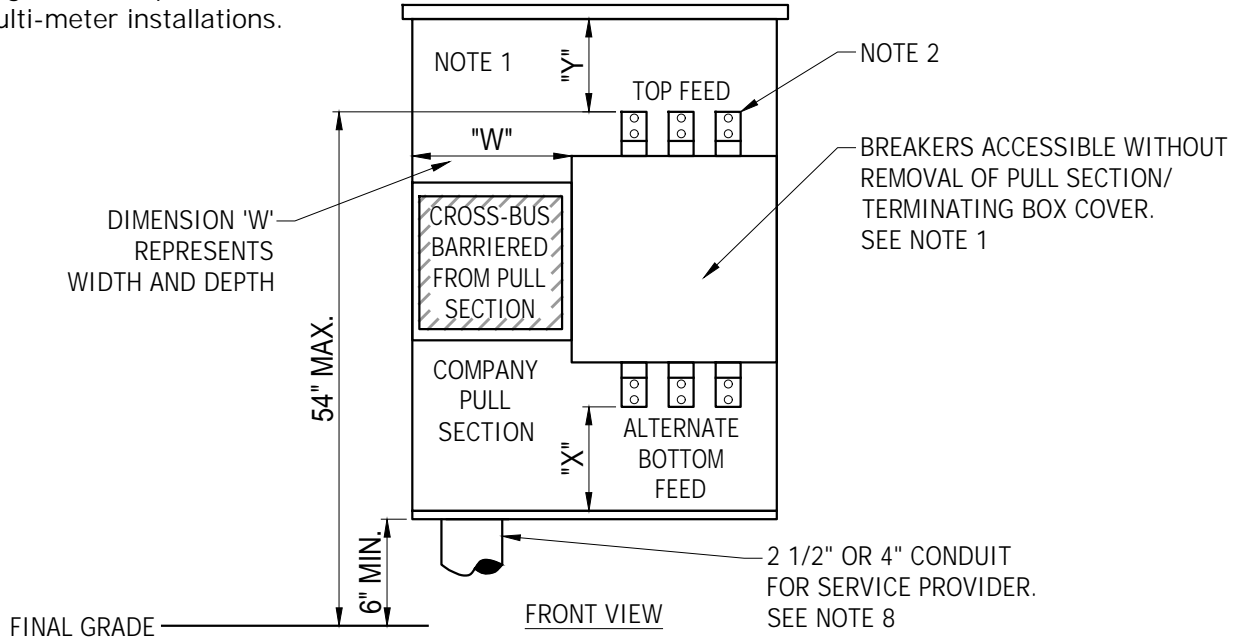

MULTIPLE OCCUPANCY RESIDENTIAL UNITS, 100-125A METER SOCKETS

NUMBER OF METER SOCKETS	SERVICE ENTRANCE AMPACITY	CONNECTOR RANGE SEE NOTE 3	MINIMUM DIMENSION (IN INCHES)			CONDUIT SIZE (IN INCHES) SEE NOTE 4
			"W"	"X"	"Y"	
2 THRU 3	200	1/0 AWG - 250 KCMIL	4 1/2	11	6	2 1/2
4 THRU 10	400-800	1/0 AWG - 350 KCMIL	4 1/2	11	6	2 1/2
OVER 10	CONSULT DESIGN SERVICES					

MULTIPLE OCCUPANCY RESIDENTIAL UNITS, 200A METER SOCKETS

NUMBER OF METER SOCKETS	SERVICE ENTRANCE AMPACITY	CONNECTOR RANGE SEE NOTE 3	MINIMUM DIMENSION (IN INCHES)			CONDUIT SIZE (IN INCHES) SEE NOTE 4
			"W"	"X"	"Y"	
2 THRU 3	400	1/0 AWG - 350 KCMIL	7	11	4.5	2 1/2
OVER 3	CONSULT DESIGN SERVICES					
750 KCMIL SERVICE LATERALS	350 KCMIL - 750 KCMIL		6	16	8	4

MULTIPLE OCCUPANCY COMMERCIAL UNITS, 100A-125A METER SOCKETS

NUMBER OF METER SOCKETS	SERVICE ENTRANCE AMPACITY	CONNECTOR RANGE SEE NOTE 3	MINIMUM DIMENSION (IN INCHES)			CONDUIT SIZE (IN INCHES) SEE NOTE 4
			"W"	"X"	"Y"	
2 THRU 3	200-300	1/0 AWG - 350 KCMIL	4 1/2	11	6	2 1/2
4 THRU 6	400-600	350 KCMIL - 750 KCMIL	6	16	8	4

MULTIPLE OCCUPANCY COMMERCIAL UNITS, 200A METER SOCKETS

NUMBER OF METER SOCKETS	SERVICE ENTRANCE AMPACITY	CONNECTOR RANGE SEE NOTE 3	MINIMUM DIMENSION (IN INCHES)			CONDUIT SIZE (IN INCHES) SEE NOTE 4
			"W"	"X"	"Y"	
2 THRU 4	400-600	350 KCMIL - 750 KCMIL	6	16	8	4



INITIATED BY
ESR COMM.

SC
1-80

REVISION NO.
ESR COMM.
EFFECTIVE DATE

7
2-24
2-24



SR-426 
Pg. 2 of 2

COMMERCIAL CT POWER AND CONTROL
CABINET, 400 - 800A



NOTES:

1. Approved Equipment
 - a. Milbank Catalog No. CP3FFBCxxxxxAxxTEP
 - b. Milbank Catalog No. CP3FGBCxxxxxAxxTEP
2. Cabinet usage is limited to commercial customers with a load 800A or less.
3. See SR-405 for general metering installation requirements.
4. A level standing and working surface shall be provided and maintained in front of each metering installation . A clear and unobstructed working space shall be provided above this surface, see SR-405 for requirements.
5. Two 1/2 inch steel bolts shall be provided for each mounting positions. Each bolt shall be secured in place and furnished with a spring washer and a nut. The spring washer may be either a cone type (Belleville) or a split ring washer and a flat washer.
6. All parts shall be plated to prevent corrosion.
7. Customer to provide and terminate service conductor.
8. The point of delivery shall be at a secondary junction box or at a pad-mount transformer or at some other point as may be designated by Design Services. The customer's conductors between the point of delivery of the service and the cabinet shall pass through no other equipment. The "neutral" (and the "power leg" if delta-connected 240/120V service is furnished) shall be identified per the National Electrical Code. All service conductors shall be marked (taped) in accordance with SR-405 Note 16. If conductors are parallel, they shall be grouped and identified at the point of delivery. If more than one raceway of magnetic metal conduit is used for parallel conductors, one conductor from each phase plus one neutral conductor must pass through each conduit. The neutral of each set of service conductors must be identified with an address tag at the transformer or junction box location. Example: Dymo Aluminum embossing tape or other approved methods. Customer conductors that connect to Service Provider equipment shall be no greater than 600kcmil.
9. Enclosure door shall be equipped with a handle operated latching mechanism, and lockable with a padlock having a 5/16 inch lock-shaft. A device shall be provided to secure the door in the open position at 90-degrees or more.
10. All section covers shall be independently removable and equipped with stops to prevent inward swinging beyond the front surface of the service section. Upper cover shall be non-removable when meter is in place. Lower cover shall be sealable and permanently labeled: "DO NOT BREAK SEAL, NO FUSES INSIDE".
11. Internal equipment shall be secured in place without screws or nuts on the outer surface of the enclosure that may be loosened from the outside.
12. All utility compartments (meter cover, demand reset cover, and pull section) shall be sealable and pad-lockable.
13. The meter shall be enclosed. The enclosing cover (top and front) shall be hinged or the top may be fixed in place if the front is removable.
14. Ringless sockets are not acceptable.
15. A protective metallic barrier (16 gauge minimum) shall be installed between the utility wireway and the customer distribution section. There shall be a 1/4 inch minimum clearance between the customer section and protective barrier to prevent screws and bolts from protruding into the termination section.
16. At no time shall an alternate power source exist in parallel operation with The Company's distribution system. Any mechanical or automatic means of source transfer or throw-over must operate in open transition (break-before-make).

 Tucson Electric Power	 SANTA CRUZ COUNTY	INITIATED BY	EKD	REVISION NO.	0	SR-429 Pg. 1 of 2
		ESR COMM.	2-24	ESR COMM.	2-24	
				EFFECTIVE DATE	2-24	

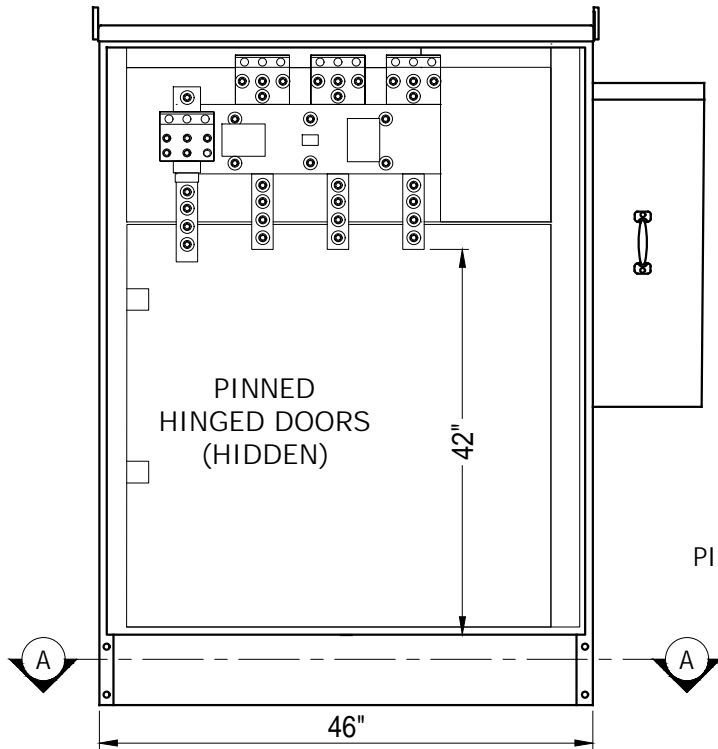

FRONT VIEW
UTILITY SECTION

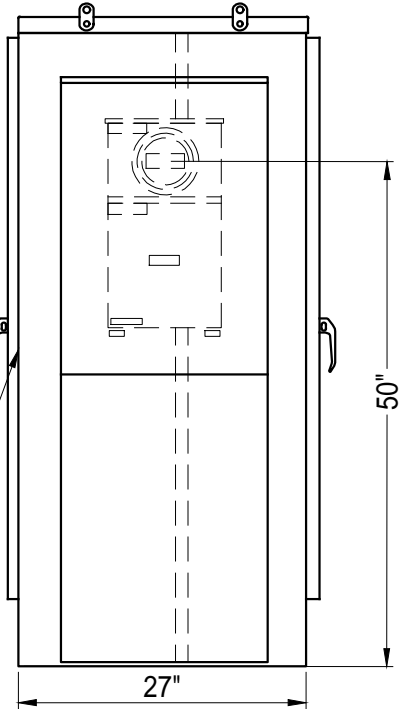

SIDE VIEW
METER ENCLOSURE

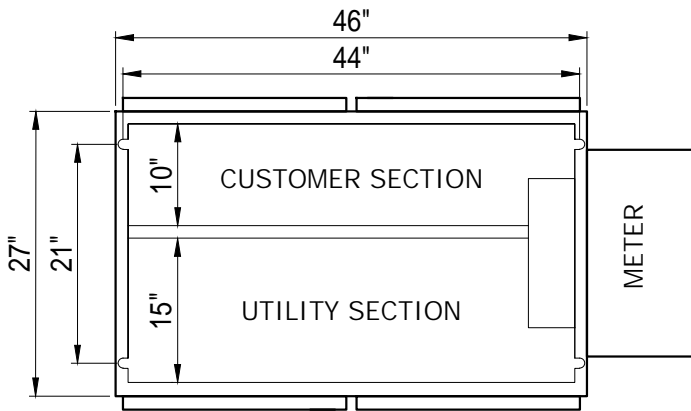

SECTION A-A
MOUNTING DETAIL

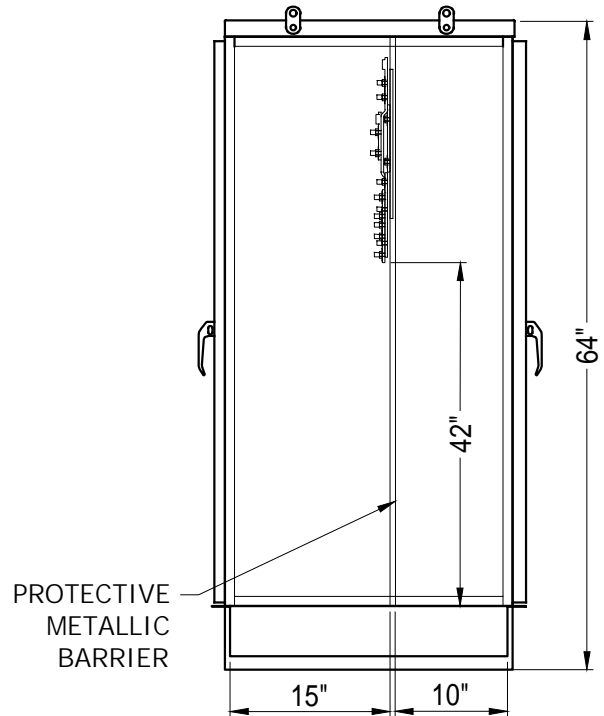

SIDE VIEW
INTERIOR DETAIL

PINNED HINGED
DOOR (TYP.)

PROTECTIVE
METALLIC
BARRIER

CURRENT TRANSFORMER INSTALLATION IN SWITCHGEAR, 0-600V



1. APPLICABLE LOADS AND VOLTAGES

Switchgear with a current transformer (CT) compartment may be used at all of the Company's service voltages less than 600V with service entrance ampacities as follows:

- a. Single-Phase, 3W, 401-800A (2 CTs)
- b. Three-Phase, 4W, 201-3000A (3 CTs)
- c. Three-Phase, 4W, 3001A and Larger (3 CTs), special engineering required

2. GENERAL PROCEDURE

The customer's switchgear shall contain a CT compartment which is for the exclusive use of the Service Provider. If the switchgear is located in an accessible place outside of the building or in a meter room, the meter socket(s) and test switch may be installed on a panel in the CT compartment door. If switchgear is not located outside of the building or in a meter room, see SR-405, Page 2 and Page 8, the customer installs a continuous metering conduit, minimum size of 2 inch diameter from the CT compartment to the meter socket(s), see SR-431. The meter socket(s) must be located outside of the building in an accessible space. Unused hubs shall be capped off with a rainproof access plate(s) that is secured internally utilizing a carriage bolt and a wingnut bar that spans beyond the opening, see SR-405. Following inspection and approval of the customer's installation by Design Services, the Company will provide and install the required number of CTs, the metering conductors and the meter(s).



3. CT COMPARTMENT REQUIREMENTS

The size and specifications of the compartment shall meet the requirements of SR-432 through SR-439. Different size and specifications are required based on service entrance ampacities. The CT compartment cover panels, any blank panels and the pull section cover shall be made sealable by using studs and wing nuts or captive sealing screws. The CT compartment must be barriered from all load bus or load conductors.

The bus structure in the CT compartment shall provide for mounting of the proper size and kind of CTs for the ampacity required. The customer shall furnish all bolts, nuts, flat washers and lock washers needed to mount the CTs. The CT bolts shall be maximum 1/2 inch and minimum 3/8 inch in diameter. They shall be fully threaded except for the portion within 3/8 inch of the bus and shall be long enough to be threaded completely through the nut when a CT with a bar 1/2 inch thick is mounted with flat and pressure maintaining spring washers.

4. DUAL LOCKING ARRANGEMENT FOR OUTDOOR OR RAIN TIGHT-TYPE SWITCHGEAR

To facilitate Company access to meters and/or the CT compartment, the customer shall provide a dual-hasp locking arrangement on the doors of outdoor or raintight-type switchgear.

		INITIATED BY	SC	REVISION NO.	13	SR-430	
		ESR COMM.	2-81	ESR COMM.	9-20		Pg. 1 of 2
				EFFECTIVE DATE	9-20		

CURRENT TRANSFORMER INSTALLATION IN SWITCHGEAR, 0-600V



5. TEST SWITCH AND METER SOCKET

Meter socket(s) are installed and supplied by the manufacturer; 13 terminal socket for three-phase, 6 terminal socket for single-phase.

NOTE: Test Switches are not supplied by the panel manufacturer and must be supplied by the customer.

For single and three-phase systems, a test switch and cover or exact equivalent must be provided.

Approved Test Switches

Milbank, Cat. No. TS10-0016

Durham, Cat. No. 1-1058F-129

Brooks Utility Products, Cat. No. 11 OU2455-1 PF, Three-phase

Brooks Utility Products, Cat. No. 107U9335-PF, Single-phase

States Products, Cat. No. 410-V, Three-phase



Tesco, Cat. No. 910899-C, Three-phase (Cover included)

Tesco, Cat. No. 910898-C, Single-phase (Cover included)

Approved Covers

Milbank, Cat. No. K-3388-BLK-FL

Durham, Cat. No. 7943BC-00

Brooks Utility Products, Cat. No. 209-PF, Single and Three-phase

States Products, Cat. No. C2 or C4, Three-phase

6. SWITCHGEAR

Switchgear manufactured according to the requirements of the Electric Utility Service Equipment Requirements Committee (EUSERC), is acceptable. The EUSERC plates relating to installations as described in SR-432 through SR-439 are noted on each SR drawing.

		INITIATED BY	SC	REVISION NO.	15	SR-430 Pg. 2 of 2
		ESR COMM.	2-81	ESR COMM.	7-25	
				EFFECTIVE DATE	7-25	

USE: Typical installation of
switchgear with meter
sockets remote

METERING, REMOTE

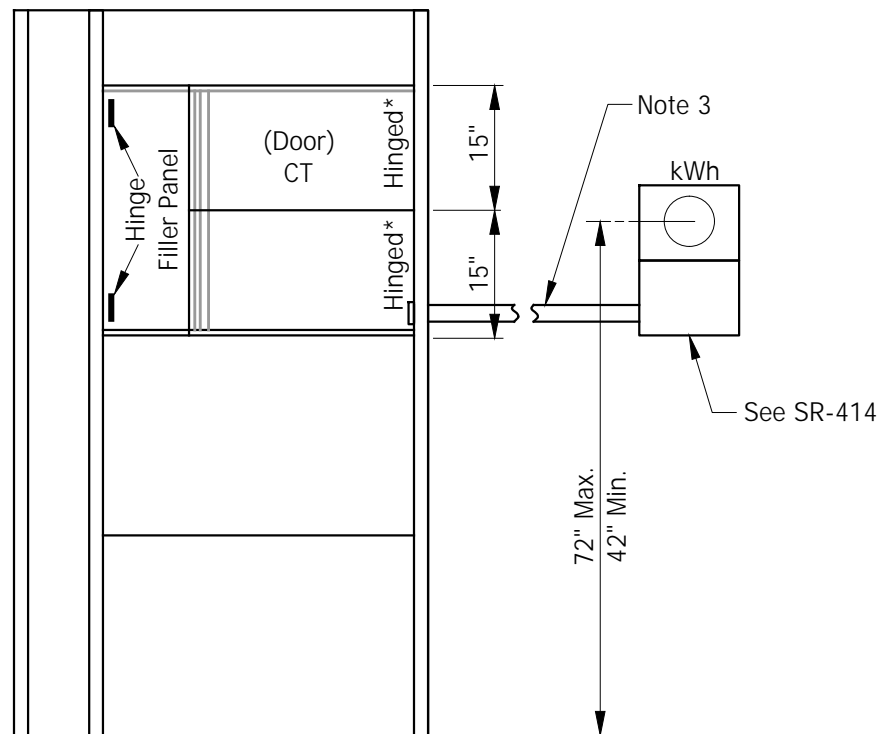

TYPICAL INSTALLATION

NOTES:

1. See SR-430 for general requirements.
2. If switchgear is located in an inaccessible area, such as a basement or roof, the meters must be located outside in a readily accessible area. Meters must not be installed in any area that may be kept under the customer's lock and key.
3. Conduit for metering wire from the Current Transformers (CT) compartment, to the meter socket enclosure is provided by the customer and shall enter the meter socket enclosure at the hub or the precut knockouts. Conduit shall not interfere with the operation of the test switch. The metering conduit shall not have more than three 90° bends, or any combination of bends greater than 270°. The metering conduit shall not exceed 120 ft. in maximum length. Conduit must be minimum 2" diameter. A pull rope must be installed in conduit runs in excess of 50 ft. (Note: 1-1/4" conduit may be used if length is less than 50 ft. and there is no more than one 90° bend). Accessible and sealable pulling junctions are allowable if needed. The opening in the CT compartment shall be in front of, not blocked by, the bus bars.
4. Maintain 36 inch working space in front of the current transformer compartment and meter socket(s).



		INITIATED BY	SC	REVISION NO.	3	SR-431 Pg. 1 of 1
		ESR COMM.	10-81	ESR COMM.	5-18	
				EFFECTIVE DATE	5-18	

USE: Combination terminating pull section and current transformer compartment, 0-600V, for underground, outdoor application.

SWITCHBOARDS, LOW PROFILE

EUSERC DWG. NO. 325/326

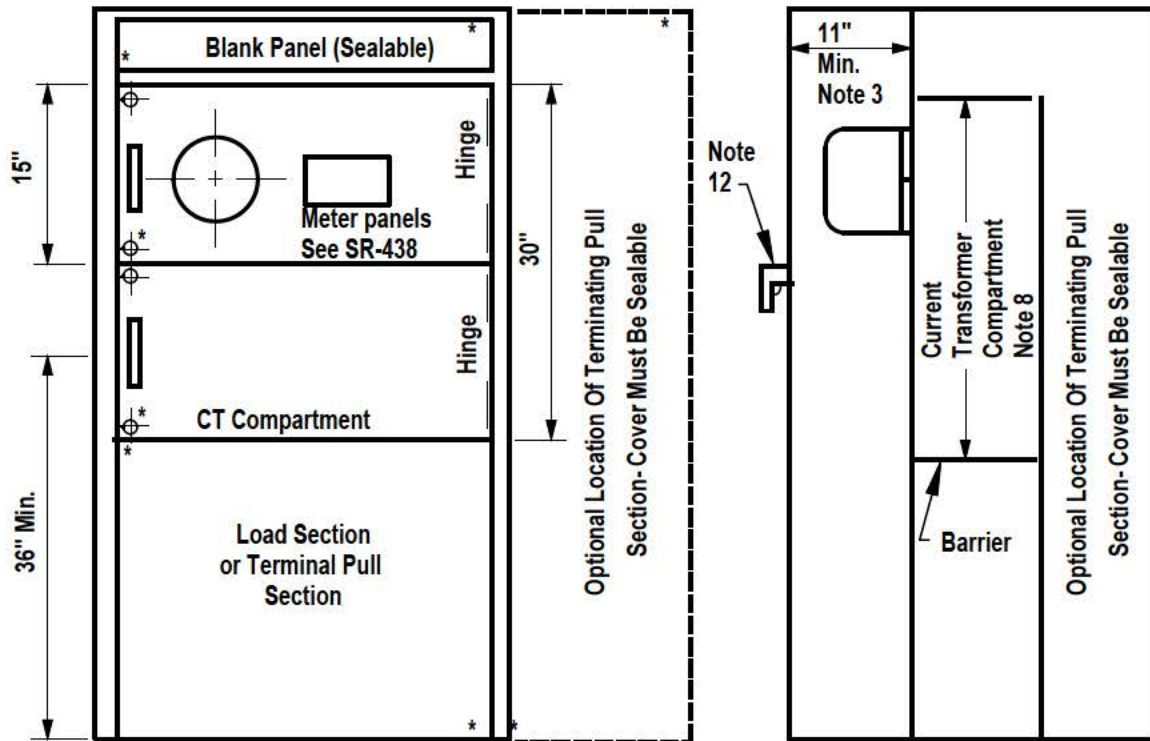

1. See SR-430 for general requirements.
2. Terminating pull section shall be located beside, behind or beneath the current transformer compartment.
3. Refer to SR-437 for door and hinge details on meter panel enclosure.
4. Filler panels shall be used where switchboard width exceeds maximum allowable meter panel width.
5. Meter panels shall not be hinged on filler or pull section panels.
6. Width of meter panels may, in some cases, require the service section to be wider than the minimum allowable width of current transformer compartment. See SR-437 and SR-438 for meter panel dimensions.
7. For current transformer compartment requirements and minimum dimensions, refer to the following plates:

401 to 800 A, 1Ø - See SR-433	1001 to 3000 A - See SR-435
201 to 1000 A, 3Ø - See SR-434	3001 and Larger - See SR-436
8. Current transformer compartments shall be bussed with rectangular bus bar.
9. Grounding connection shall be made in the main switch or breaker compartment.
10. Maintain 36" working space in front of the current transformer compartment.
11. See SR-430 for requirement for double locking arrangement. The CT compartment cover panels, the blank filler panels and pull section cover shall be sealable in approximately the locations indicated by the asterisks (*) in the above drawing.
12. Meter panels & filler panels shall be equipped with stops to prevent inward swinging beyond the front surface of the service section.

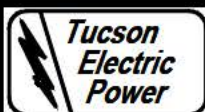

INITIATED BY	SC
STANDARDS COMM.	10-81

REVISION NO.	6
STANDARDS COMM.	12-13
EFFECTIVE DATE	1-14

SR-432
Pg. 1 of 1

CT COMPARTMENT, 401-800A, 1Ø ←
FOR SWITCHBOARDS 0-600V

EUSERC DWG. NO. 319

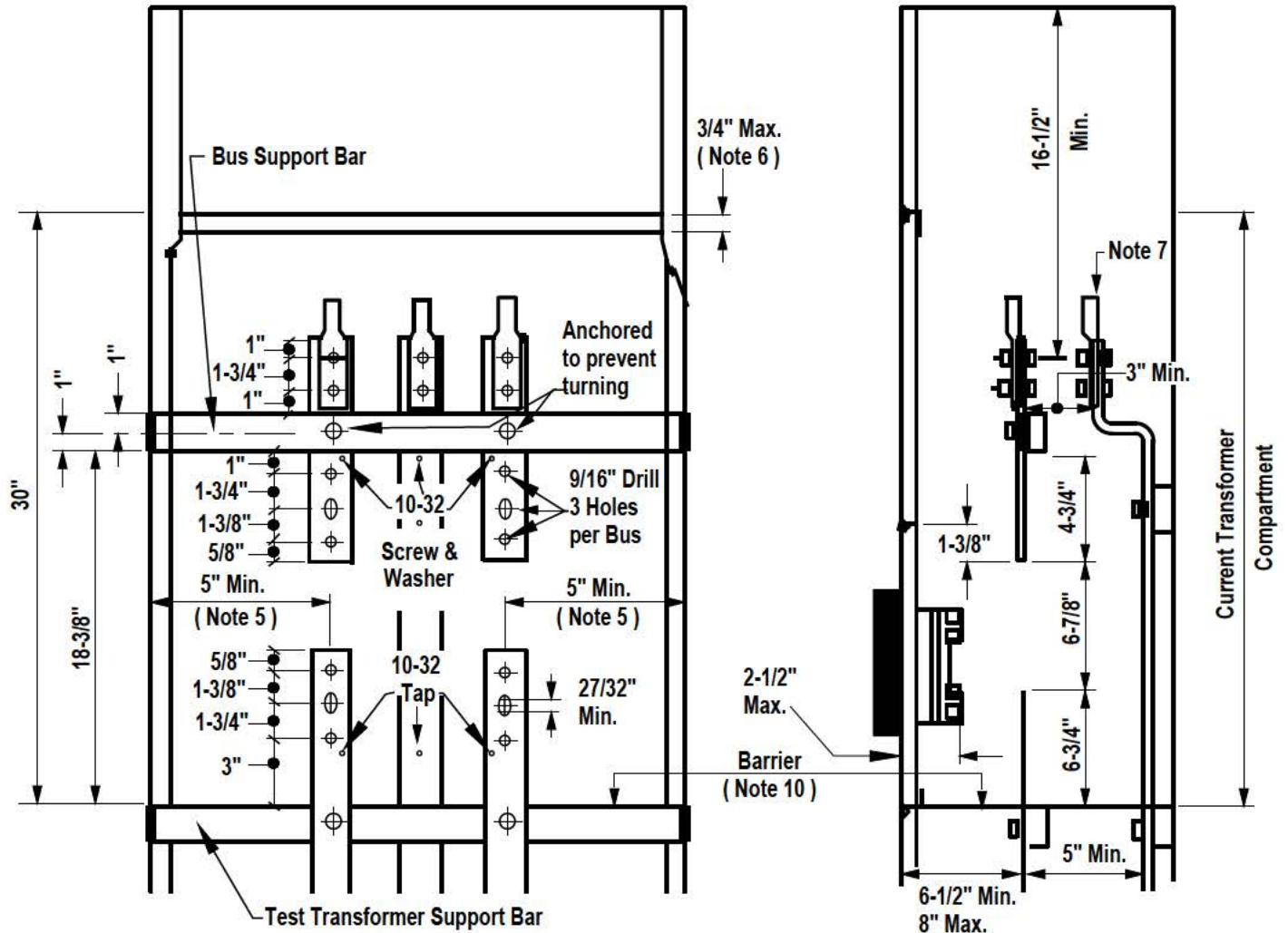

NOTES:

1. See SR-430 for general requirements.
2. Bus arrangement and supports are required as shown above, except the neutral bus may be located on the sidewall or at either side.
3. Compartment shall be on the supply side of the main switch or breaker.
4. Direction of feed may be from top or bottom and no other conductors shall pass through this compartment. The bus shall be rectangular.
5. Clearance to side of compartment shall be increased by the amount by which the corner angle exceeds 1°.



INITIATED BY
 STANDARDS COMM.

SC
 10-81

REVISION NO.	5
STANDARDS COMM.	8-13
EFFECTIVE DATE	9-13

SR-433
 Pg. 1 of 2

**CT COMPARTMENT, 401-800A, 1Ø ←
FOR SWITCHBOARDS 0-600V**

EUSERC DWG. NO. 319

NOTES: (continued)

6. Return flanges for lower and upper meter panel support shall not project more than 3/4" up or down from adjacent switchboard panels.

7. Each bus shall have a connector or connectors that will accept stranded conductors having the ampere capacity of the main switch or breaker.

8. When laminated bus is used, there shall be no space between laminations in the compartment.

9. Bus Dimensions: Max. Line Side - 3/4" x 4"; Min. - 1/4" x 2"
Max. Load Size - 3/4" x 2"; Min. - 1/4" x 2"

10. Barrier shall be of insulating nontracking material resistant to arc tracking, be rigid, with a maximum deflection of 1/2 inch from an applied force of 25 pounds downward, be secured in place, be perforated with 3/8 inch maximum diameter holes to allow ventilation in accordance with NEC, be dimensioned in physical size to fit the switchboard with a peripheral gap not to exceed 3/8 inch, and contain cutouts for through bus bars with dimensions to provide a gap between bus and barrier not to exceed 3/8 inch.



INITIATED BY	SC
STANDARDS COMM.	10-81

REVISION NO.	4
STANDARDS COMM.	8-13
EFFECTIVE DATE	9-13

SR-433
Pg. 2 of 2

**CT COMPARTMENT, 201-1000A, 3Ø
FOR SWITCHBOARDS 0-600V**

EUSERC DWG. NO. 320

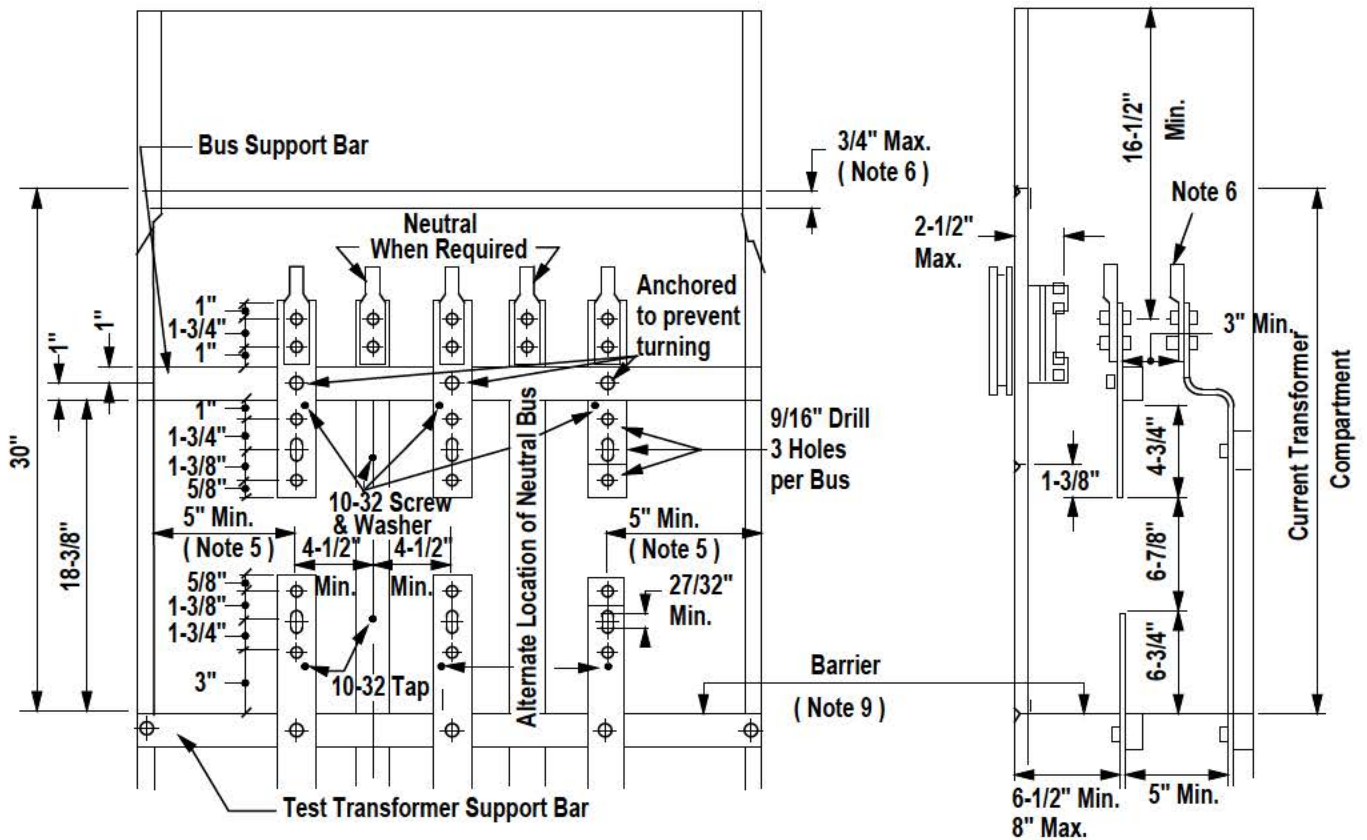

NOTES:

1. See SR-430 for general requirements.
2. Bus arrangement and supports are required as shown above, except the neutral bus may be located on the sidewall or at either side.
3. Compartment shall be on the supply side of the main switch or breaker.
4. Direction of feed may be from top or bottom and no other conductors shall pass through this compartment. The bus shall be rectangular.
5. Clearance to side of compartment shall be increased by the amount by which the corner angle exceeds 1°.
6. Return flanges for lower and upper meter panel support shall not project more than 3/4" up or down from adjacent switchboard panels.
7. When laminated bus is used, there shall be no space between laminations in the compartment.
8. Bus Dimensions: Maximum Line Side - 3/4" x 4"; Minimum - 1/4" x 2"
Maximum Load Size - 3/4" x 2"; Minimum - 1/4" x 2"
9. Barrier shall be of insulating nontracking material resistant to arc tracking, be rigid, with a maximum deflection of 1/2 inch from an applied force of 25 pounds downward, be secured in place, be perforated with 3/8 inch maximum diameter holes to allow ventilation in accordance with NEC, be dimensioned in physical size to fit the switchboard with a peripheral gap not to exceed 3/8 inch, and contain cutouts for through bus bars with dimensions to provide a gap between bus and barrier not to exceed 3/8 inch.
10. The "Power Leg" shall be identified per National Electrical Code for 4 Wire Delta Service.
11. Round bus corners as necessary to prevent damage to insulation. Bus insulation shall be adequate for the service voltage.



INITIATED BY	SC
STANDARDS COMM.	10-81

REVISION NO.	5
STANDARDS COMM.	8-13
EFFECTIVE DATE	9-13

SR-434
Pg. 1 of 1

**CT COMPARTMENT, 1001 - 3000 A, 3Ø
FOR SWITCHBOARDS 0-600 V**

EUSERC DWG. NO. 322

TOP VIEW

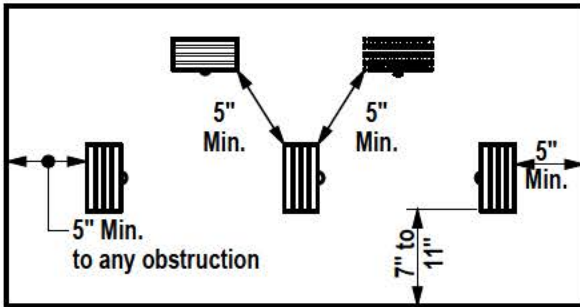

SIDE VIEW

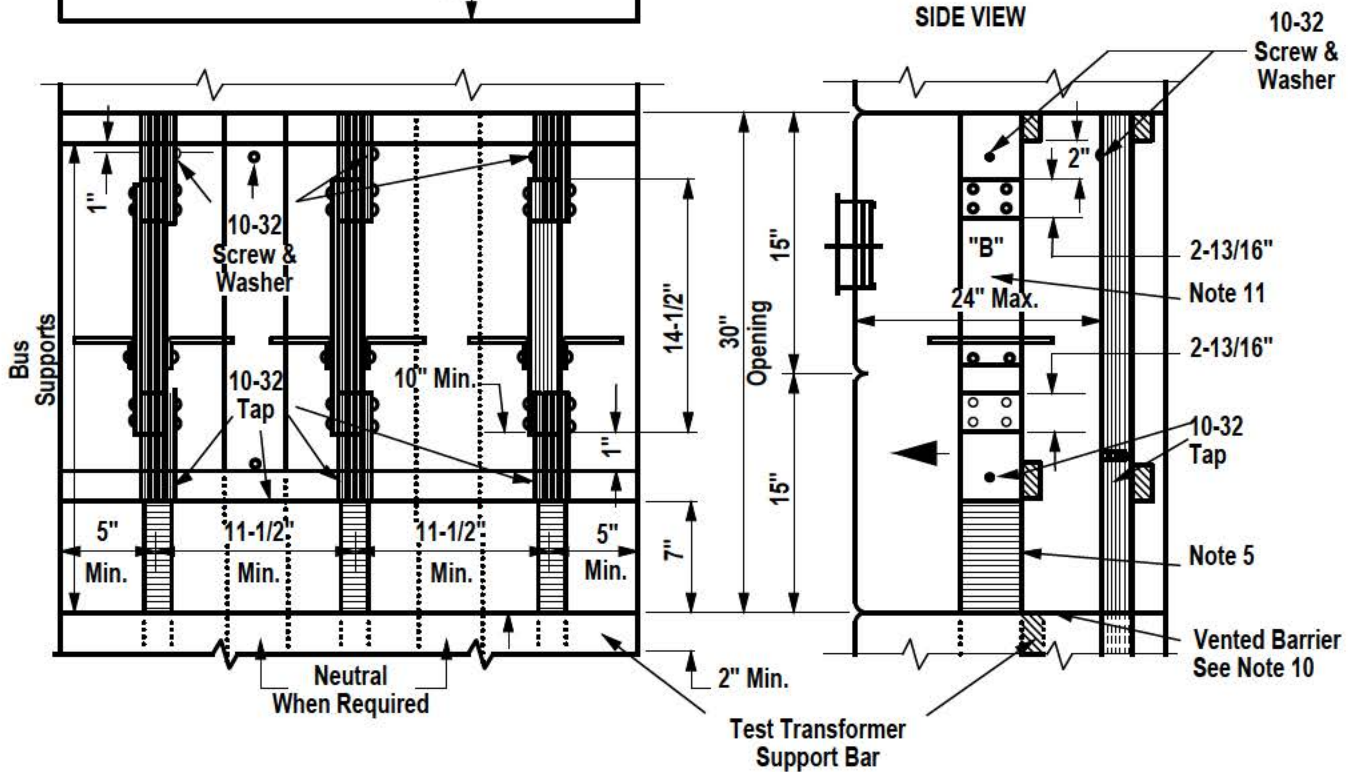

NOTES:

1. See SR-430 for general requirements.
2. Bus anchorage shall be such that busses will remain in position when removable section "B" is out.
3. Direction of feed may be from top or bottom. No other conductors shall pass through this compartment.
4. Transformer compartment shall be on the supply side of the main switch or breaker.
5. Round bus corners as necessary to prevent damage to insulation. Bus insulation to be adequate for the voltage involved.
6. The maximum permissible bus unit shall consist of four 1/4" X 4" bars space 1/4".
7. The barrier shall not be less than 45" nor more than 50" above the standing surface.



INITIATED BY	SC
STANDARDS COMM.	10-81

REVISION NO.	2
STANDARDS COMM.	10-94
EFFECTIVE DATE	1-95

SR-435
Pg. 1 of 2

**CT COMPARTMENT, 1001 - 3000 A, 3Ø
FOR SWITCHBOARDS 0-600 V**

8. Clearance to the side of the compartment shall be increased by the amount by which the corner angle exceeds 1".

9. Return flanges for lower and upper meter panel support shall not project more than 3/4" up or down from adjacent switchboard panels.

10. Barrier shall be of insulating nontracking material resistant to arc tracking, be rigid, with a maximum deflection of 1/2 inch from an applied force of 25 pounds downward, be secured in place, be perforated with 3/8 inch maximum diameter holes to allow ventilation in accordance with NEC standards, be dimensioned in physical size to fit the switchboard with a peripheral gap not to exceed 3/8 inch, and contain cutouts for through bus bars with dimensions to provide a maximum gap between bus and barrier not to exceed 3/8 inch.

11. For details of removable Section "B" and CT support, See SR-439, page 1.

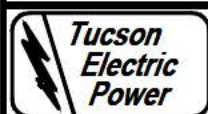

INITIATED BY	SC
STANDARDS COMM.	10-81

REVISION NO.	1
STANDARDS COMM.	10-85
EFFECTIVE DATE	1-86

REVISION NO.	1
STANDARDS COMM.	10-85
EFFECTIVE DATE	1-86

**CT COMPARTMENT, 3001 A AND LARGER,
3Ø FOR SWITCHBOARDS 0-600 V**

EUSERC DWG. NO. 324

TOP VIEW

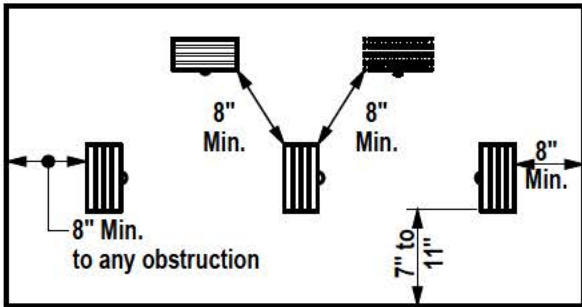
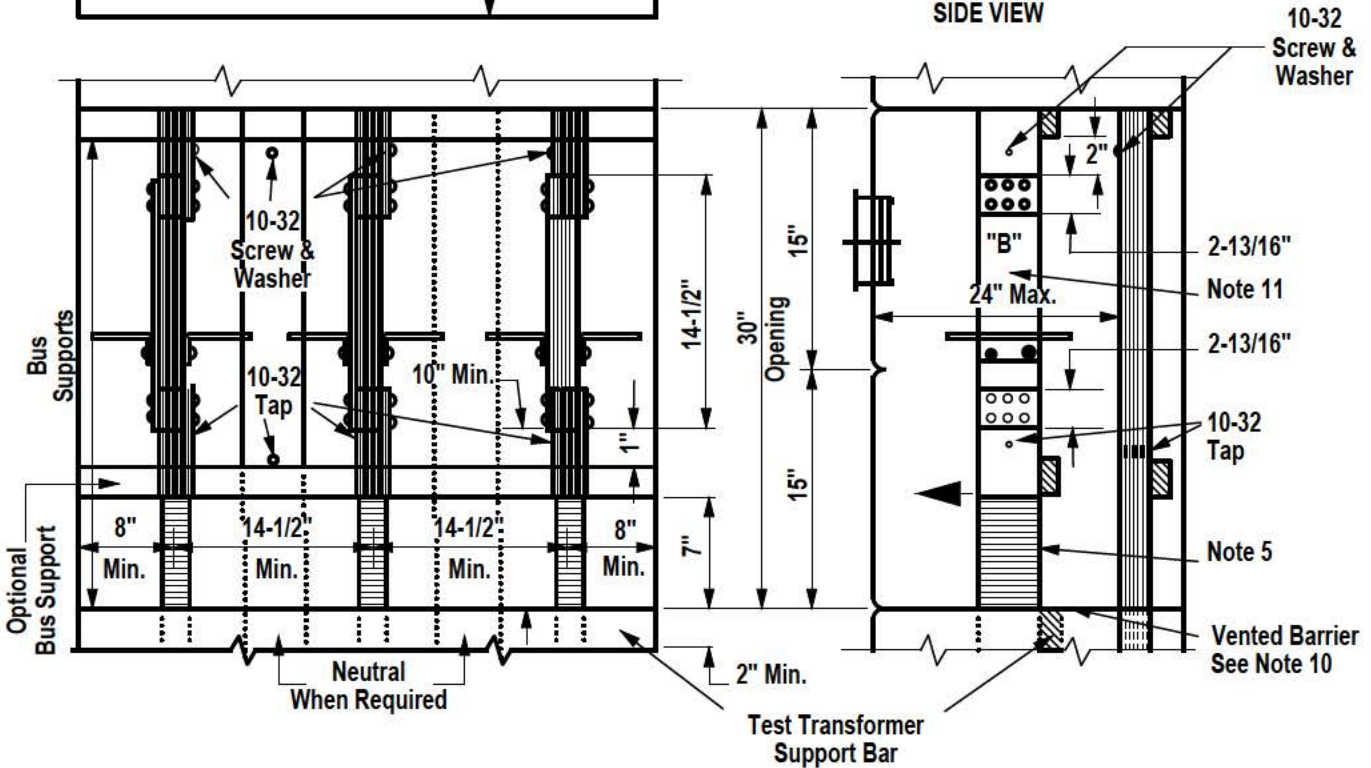

TABLE 1

Maximum Number of Bus Bars:

- 4 - 1/4" x 4" spaced 1/4".
- 6 - 1/4" x 5" spaced 1/4".
- 4 - 3/8" x 5" spaced 3/8".
- 5 - 3/8" x 5" spaced 1/4".

SIDE VIEW



NOTES:

1. See SR-430 for general requirements.
2. Bus anchorage shall be such that busses will remain in position when removable section "B" is out.
3. Direction of feed may be from top or bottom. No other conductors shall pass through this compartment.
4. Transformer compartment shall be on the supply side of the main switch or breaker.
5. Bus shall be rectangular with corners rounded as necessary to prevent damage to insulation. Bus insulation to be adequate for the voltage.



INITIATED BY	SC
STANDARDS COMM.	10-81

REVISION NO.	3
STANDARDS COMM.	10-94
EFFECTIVE DATE	1-95

SR-436
Pg. 1 of 2

**CT COMPARTMENT, 3001 A AND LARGER,
3Ø FOR SWITCHBOARDS 0-600**

NOTES: (continued)

6. The maximum bus unit (without special permission) shall consist of six 1/4" x 5" bars spaced 1/4".

7. The barrier shall not be less than 45" nor more than 50" above the standing surface.

8. Clearance to the side of the compartment shall be increased by the amount by which the corner angle exceeds 1".

9. Return flanges for lower and upper meter panel support shall not project more than 3/4" up or down from adjacent switchboard panels.

10. Barrier shall be of insulating nontracking material resistant to arc tracking, be rigid, with a maximum deflection of 1/2 inch from an applied force of 25 pounds downward, be secured in place, be perforated with 3/8 inch maximum diameter holes to allow ventilation in accordance with NEC standards, be dimensioned in physical size to fit the switchboard with a peripheral gap not to exceed 3/8 inch, and contain cutouts for through bus bars with dimensions to provide a maximum gap between bus and barrier not to exceed 3/8 inch.

11. For details of removable section "B" and CT support for 4" bus, see SR-439, Page 1; for 5" bus, see SR-439, Page 2. Consult TEP Metering Department or Service Provider for use of bus bars larger than 5".

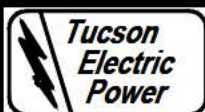

INITIATED BY	SC
STANDARDS COMM.	10-81

REVISION NO.	1
STANDARDS COMM.	10-85
EFFECTIVE DATE	1-86

REVISION NO.	1
STANDARDS COMM.	10-85
EFFECTIVE DATE	1-86

**SR-436
Pg. 2 of 2**

**ENCLOSED METER PANELS
IN RAINTIGHT SWITCHGEAR 0-600V**

EUSERC DWG. NO. 354
(Modified)

Front Views

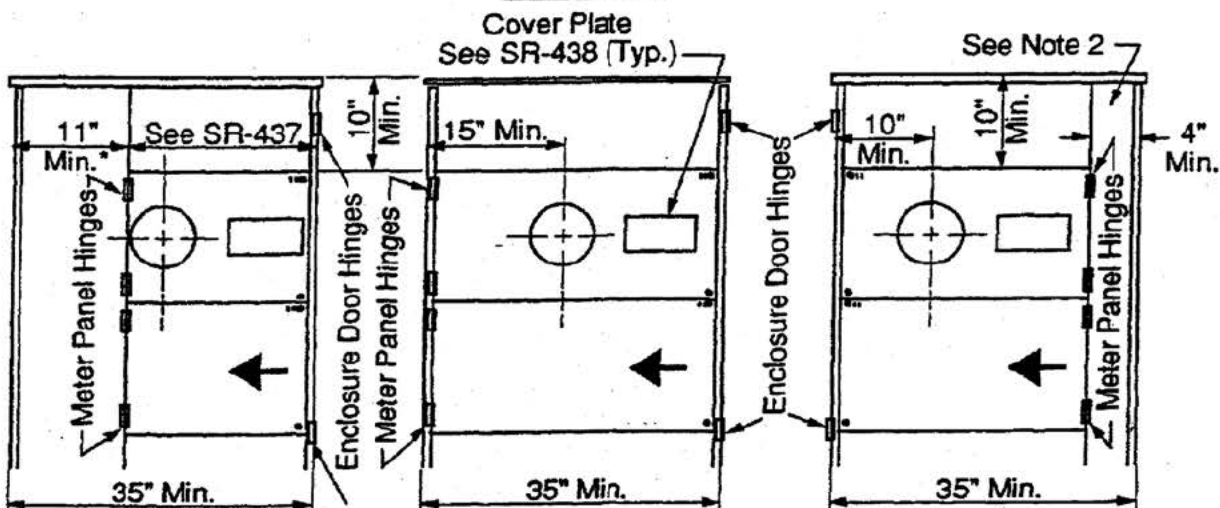
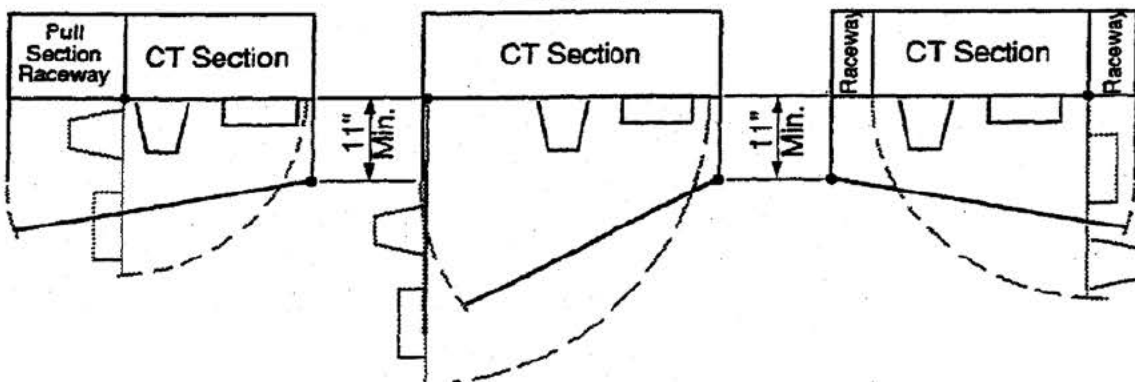

Fig. 1

Fig. 2

Fig. 3

Top Views



NOTES:

1. See SR-430 for general requirements.
2. Hinged meter panels shall be capable of being opened 90° with meter and test facilities in place. The hinges shall be readily interchangeable right or left on the job site. For other details, SR-438.
3. All access panels above the breaker section shall be sealable.
4. The meter heights of SR-405, page 1, will apply in full switchboard height meter enclosures.
5. Recording demand meters require special meter panels and clearances in or on all switchboards. See SR-438.
6. For installations described in SR-435 or SR-436, the panel should be hinged from the sidewall. The edge of the meter socket or test switch slots shall be 1" plus the depth of the recess from the hinged side.
7. Where an adjacent obstruction extends more than 11" perpendicularly from the face of the meter panel, a 10" minimum dimension to the meter socket axis is required. For obstructions extending 11" or less from the meter panel, the side clearance shall be a minimum of 6-1/4".
8. All securing screws shall be captive. All panels and covers shall be sealable.



INITIATED BY	SC
STANDARDS COMM.	10-81

REVISION NO.	2
STANDARDS COMM.	10-94
EFFECTIVE DATE	1-95

SR-437
Pg. 1 of 1

SWITCHBOARD METER PANELS

EUSERC DWG. NO. 332

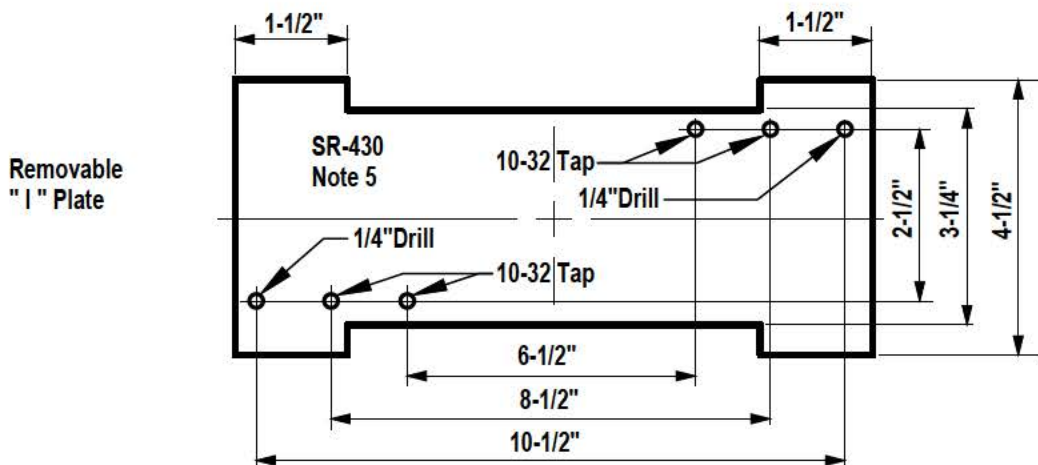
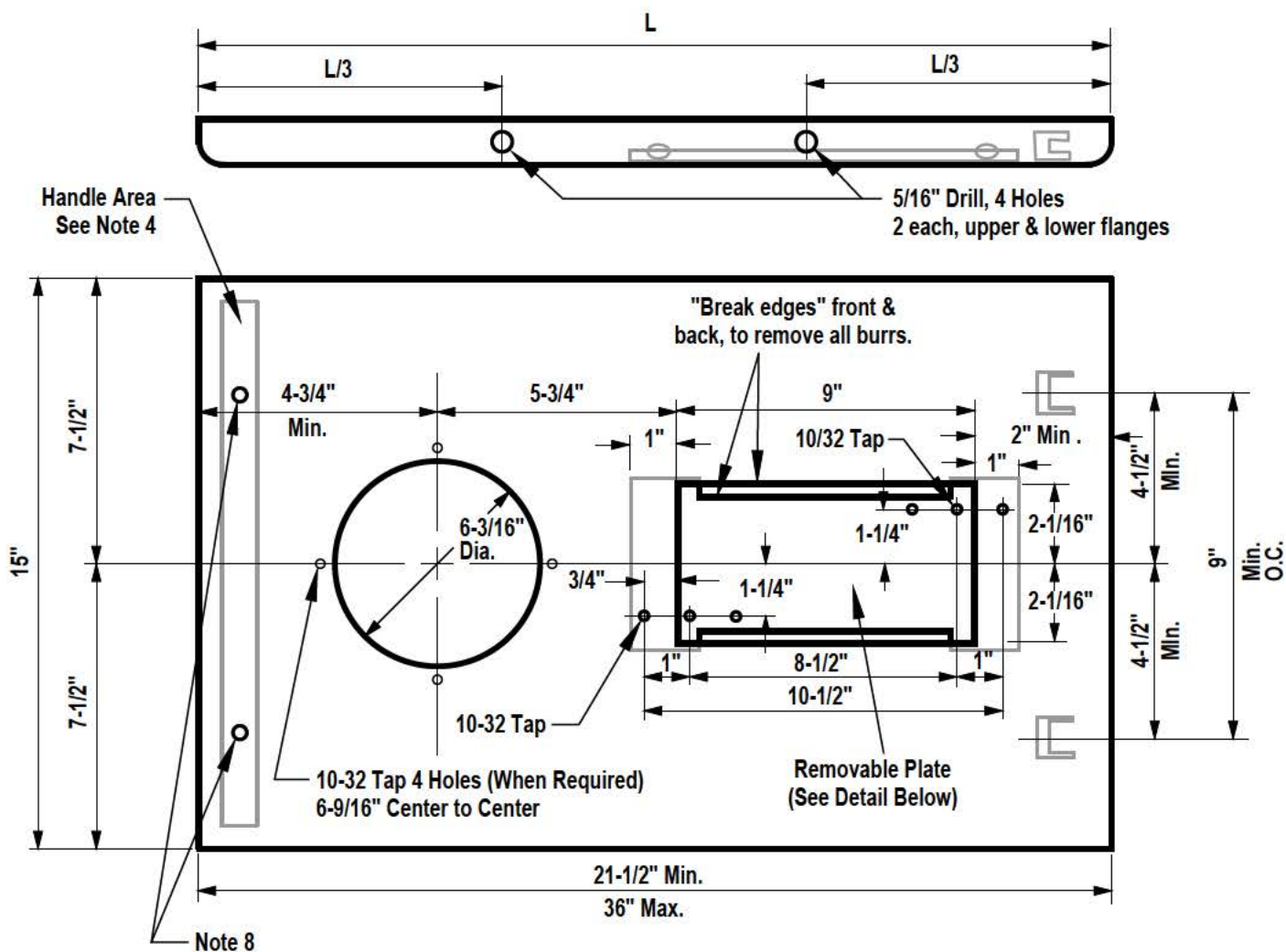

FIG. 1 - FOR ALL EXCEPT RATE 14, 90A CUSTOMERS.

See Notes, Page 3



INITIATED BY	SC
STANDARDS COMM.	10-81

REVISION NO.	5
STANDARDS COMM.	12-99
EFFECTIVE DATE	1-00

SR-438
Pg. 1 of 4

SWITCHBOARD METER PANELS

EUSERC DWG. NO. 333

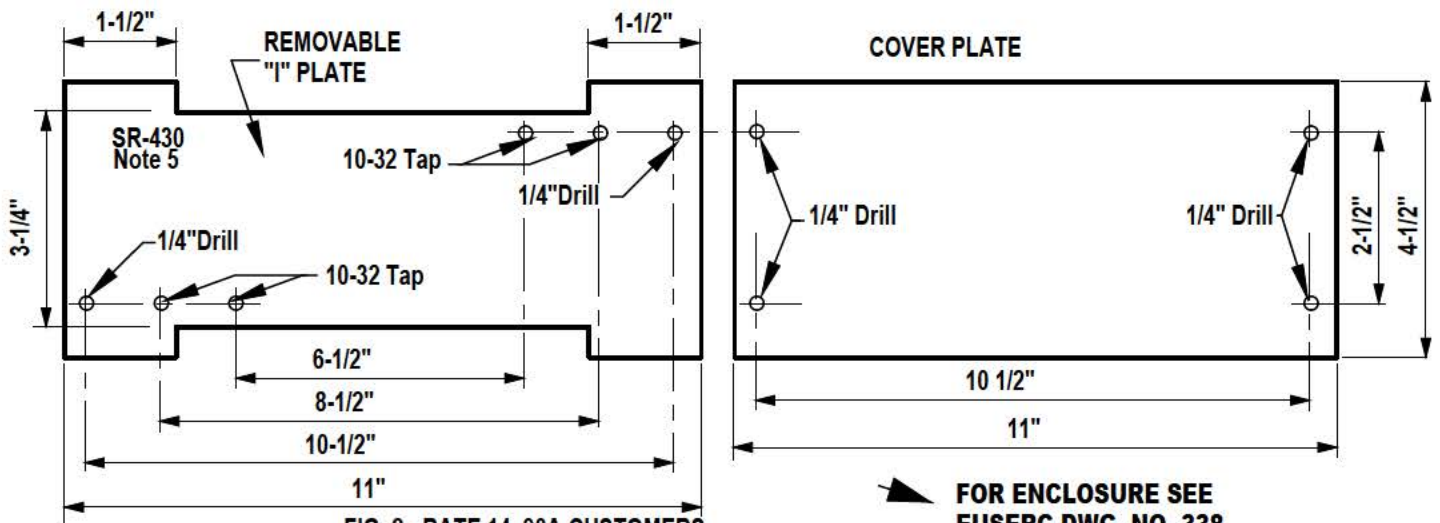
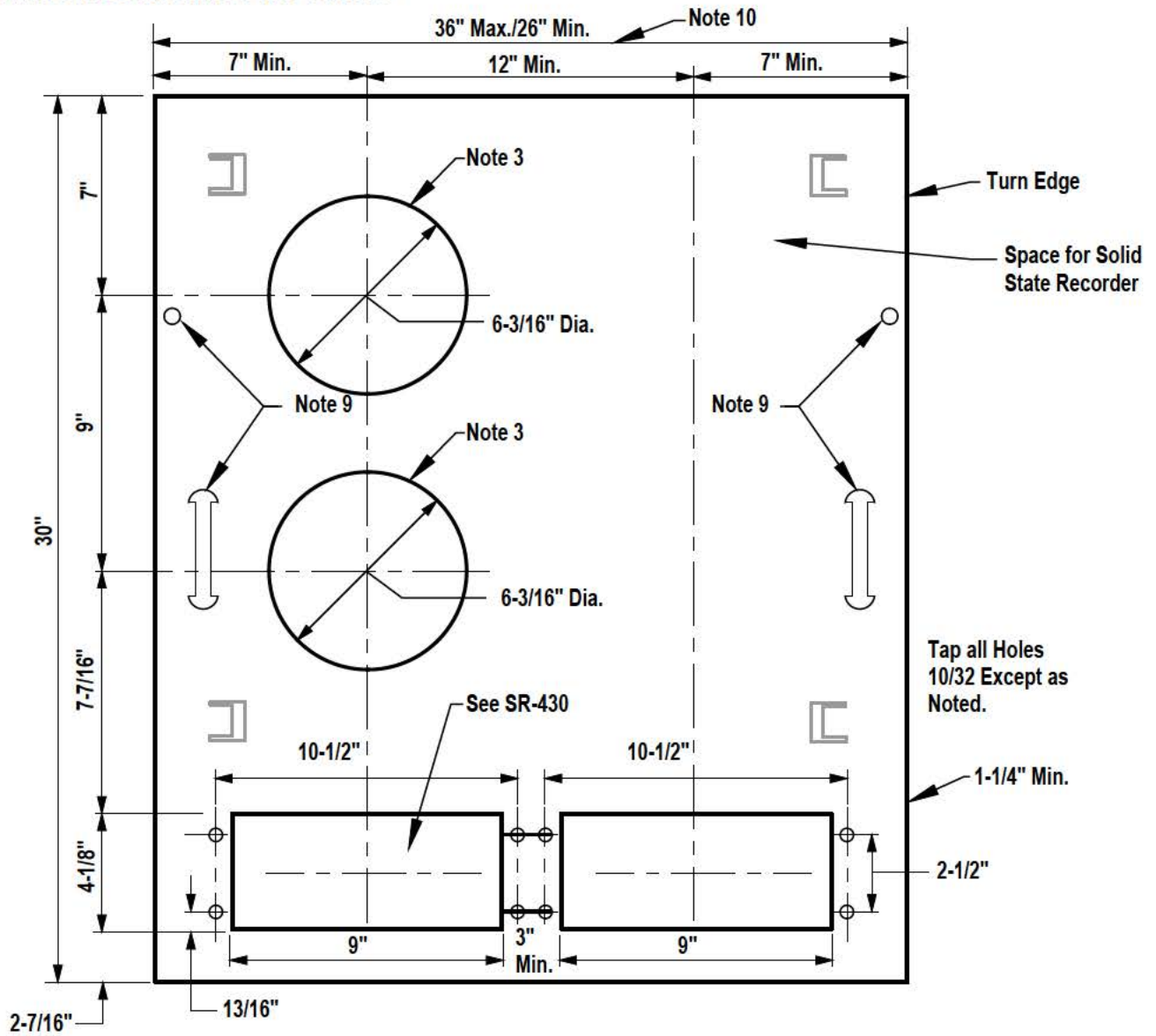

FIG. 2 - RATE 14, 90A CUSTOMERS

See Notes, Page 3



INITIATED BY	SC
STANDARDS COMM.	10-81

REVISION NO.	5
STANDARDS COMM.	1-03
EFFECTIVE DATE	1-03

SR-438
Pg. 2 of 4

Switchboard Meter Panels

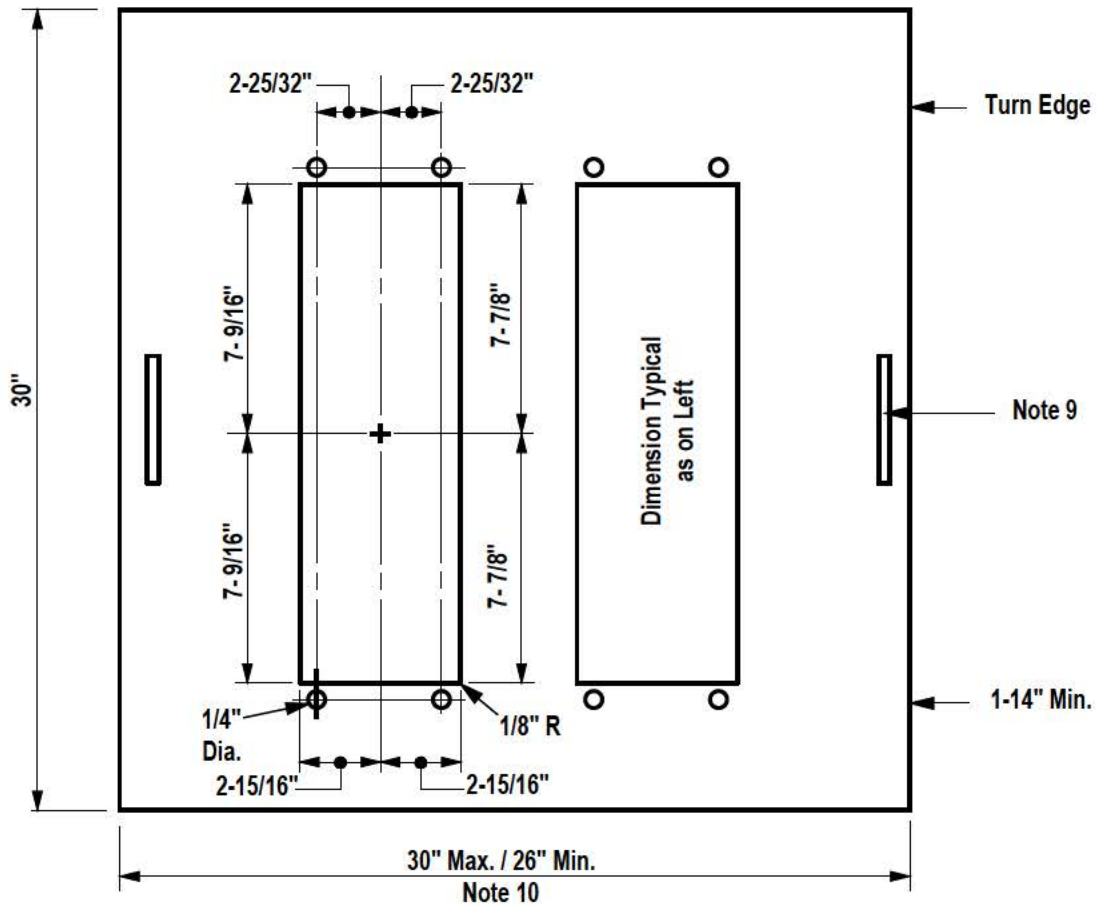

Figure 3 - Customers with Totalized Metering

Notes:

1. See SR- 430 for general requirements.
2. Meter panels shall be constructed of 12 gauge steel (minimum) and shall be hinged, reversible, sealable and interchangeable.
3. The switchboard manufacturer shall drill, tap and slot the panel as shown for secondary test switches and shall furnish and install sockets complete with sealing rings. Meter sockets installed on hinged panels shall be designed for back connection. Customer shall provide and install the appropriate test switch. **(Test switch not supplied by panel manufacturer)** See SR-430, Page 2.
4. Hinges shall be readily interchangeable, right to left, on the job site. When clevis type or removable pin type hinges are used, provision shall be made that pin can be removed from the top. Hinges must support a 25-pound load applied at unsupported end with 1/8" maximum sag when open. Meter panels shall not be hinged on filler or pull section panels.
5. A handle shall be attached at the unsupported end of the meter panel with a minimum clearance of 1" from the meter socket.

SWITCHBOARD METER PANELS

6. Meter Panels shall be capable of being opened 90° with meter and test facilities in place.
7. Removable plate(s) shall be secured to rear of panel by screw of such a length so as not to protrude through face of panel. Fig. 1 and Fig. 2 only.
8. All securing and sealing screws on panel shall be captive. Studs and wire nuts shall be sealable when used.

Additional Requirements for Rate 14, Rate 90A Customers:

9. Panel shall have handle attached to each side.
10. For panel width of less than 26", consult Design, Service Requirements & Service Delivery Department.
11. Customer shall provide a telephone line for transmitting metering data.
12. For totalized metering contact Design, Service Requirements & Service Delivery Department.



INITIATED BY	CS
STANDARDS COMM.	10-86

REVISION NO.	1
STANDARDS COMM.	8-93
EFFECTIVE DATE	1-95

REVISION NO.	1
STANDARDS COMM.	8-93
EFFECTIVE DATE	1-95

SR-438
Pg. 4 of 4

REMOVABLE BUS LINKS AND CT SUPPORTS

1001-3000 A, 0-600 V

EUSERC DWG. NO. 330

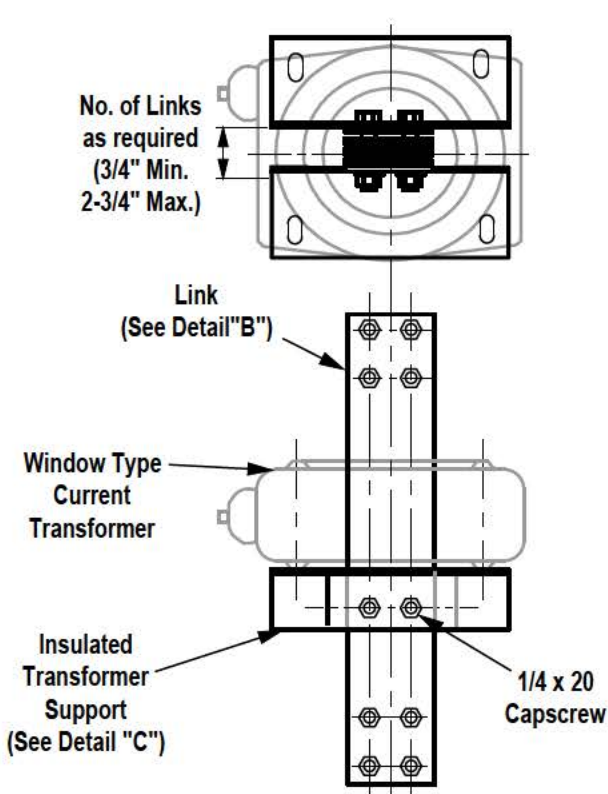

REMOVABLE LINK ASSEMBLY
(Furnished by Manufacturer)

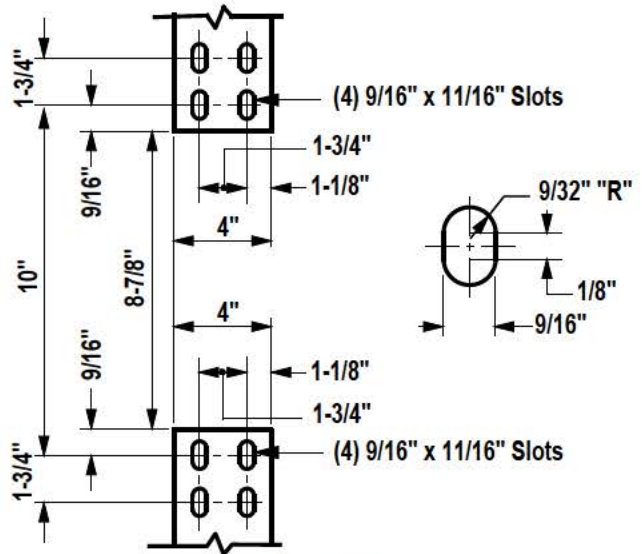

DETAIL "A"
DRILLING AND SPACING OF BUS

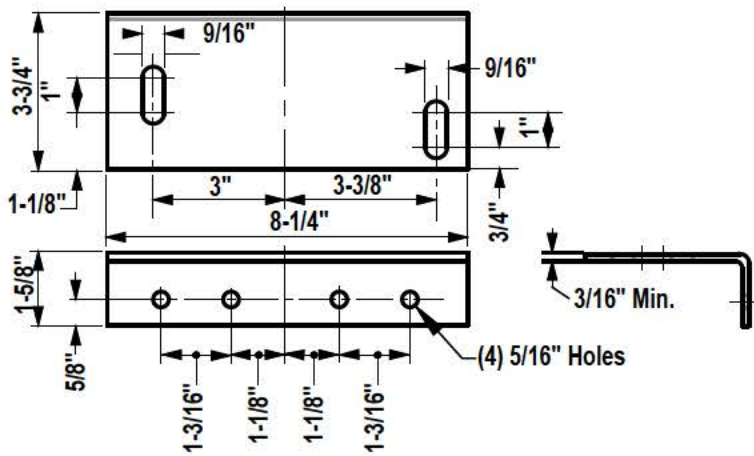

DETAIL "C"
INSULATED SUPPORT FOR
CURRENT TRANSFORMER
(Material: Insulating, Non-Tracking)

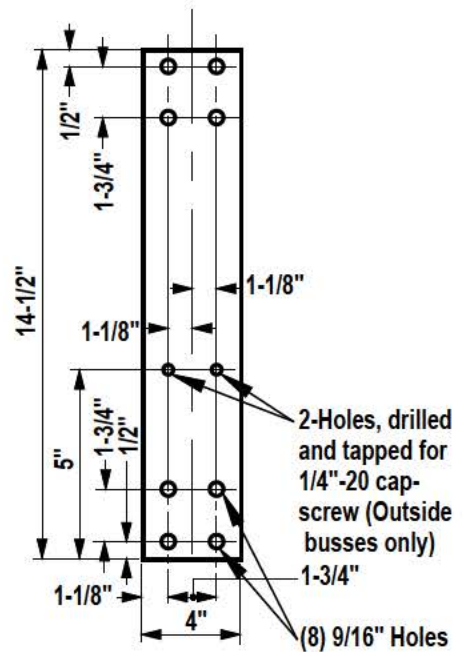

DETAIL "B"
1/4" X 4" LINK
(Same Material as Bus)

NOTE: 1. Manufacturer to provide 1/2 inch hex head bolts, nuts, & lock washers.



INITIATED BY	SC
STANDARDS COMM.	10-81

REVISION NO.	1
STANDARDS COMM.	10-85
EFFECTIVE DATE	1-86

SR-439
Pg. 1 of 2

REMOVABLE BUS LINKS AND CT SUPPORTS

3001 A and Larger, 0-600 V

EUSERC DWG. NO. 331

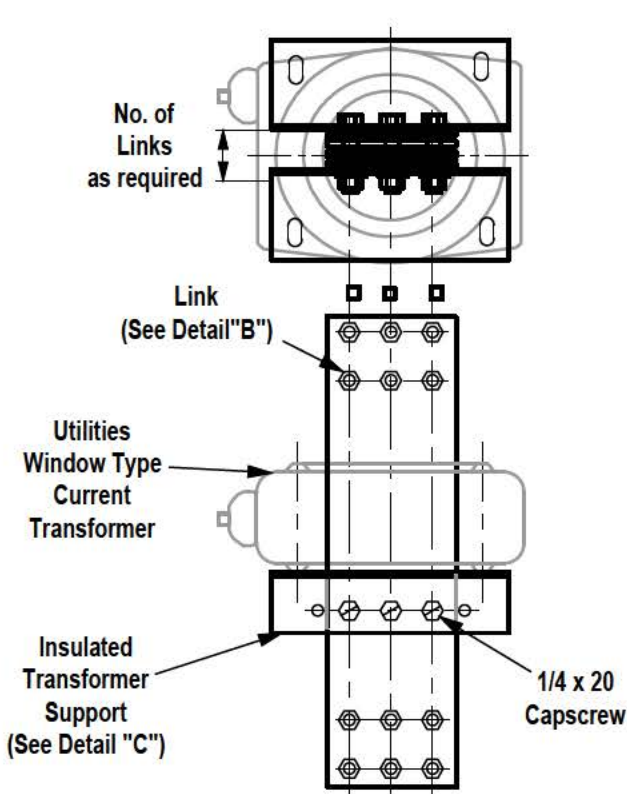

REMOVABLE LINK ASSEMBLY
(Furnished by Manufacturer)

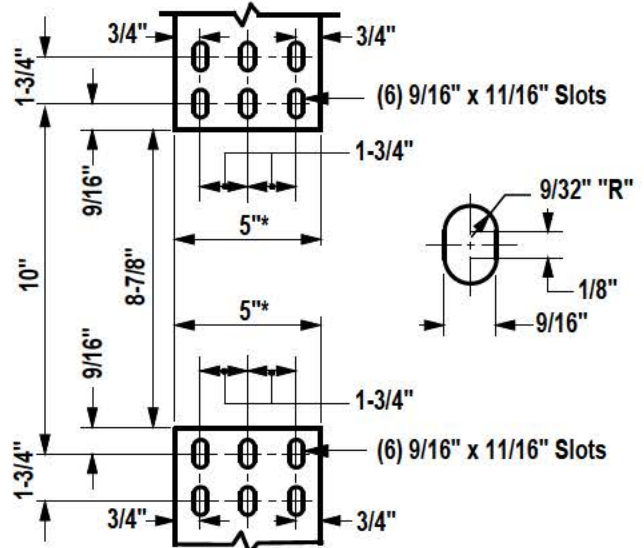

DETAIL "A"
DRILLING AND SPACING OF BUS

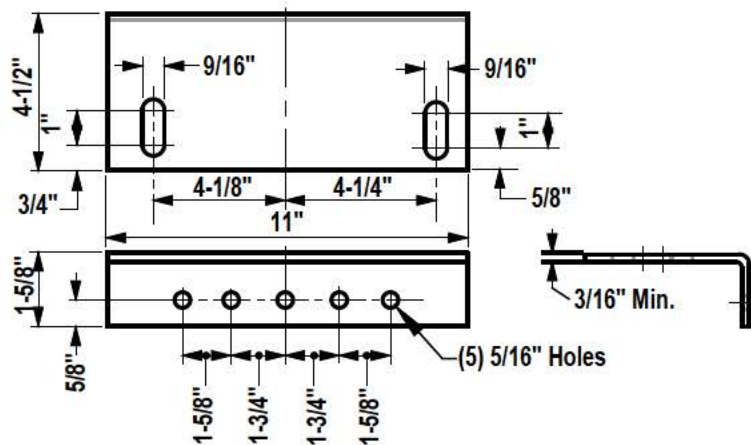

DETAIL "C"

INSULATED SUPPORT FOR CURRENT TRANSFORMER
(Material: Insulating, Non-Tracking)

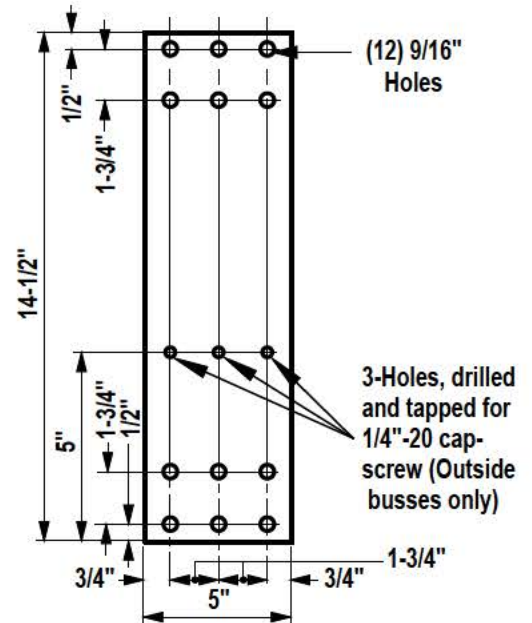

DETAIL "B"
1/4" X 5" LINK
(Same Material as Bus)

- NOTE:**
1. Manufacturer to provide 1/2 inch hex head bolts, nuts, & lock washers.
 2. Consult Design, Service Requirements & Service Delivery Department for use of bus bars larger than 5".



INITIATED BY	SC
STANDARDS COMM.	12-81

REVISION NO.	2
STANDARDS COMM.	8-93
EFFECTIVE DATE	1-94

SR-439
Pg. 2 of 2



PRIMARY METERED SERVICE

1. PURPOSE

These electric service requirements provide information necessary for metering customers receiving power at primary voltages.

2. APPLICABILITY

This document applies to all customers receiving service at voltages from 2.4kV to 13.8kV. For service at higher voltages, contact the Service Provider Commercial Account Services Department. Availability of primary metered service is at the sole discretion of the Service Provider. Consult with the Service Provider Design Department prior to initiating the project.

3. DEFINITIONS

Distribution System: The infrastructure constructed, operated, and maintained by the Service Provider to deliver electric service to retail customers at 13.8kV and less.

Point of Delivery: The physical location where Service Provider conductors and equipment are connected to Customer conductors.

Point of Service: The physical location where Customer owned facilities terminate and equipment is maintained by the Customer.

Primary Metering: Metering installed at service voltages above 600 volts.

4. STANDARDS

All customer equipment shall conform to the nationally-recognized standards and recommended practices. These include, but are not limited to:



- a. NFPA 70 - National Electric Code (NEC)
- b. IEEE C2 - National Electrical Safety Code (NESC)
- c. Electric Utility Service Entrance Requirements Committee (EUSERC) Manual

5. CUSTOMER RESPONSIBILITIES

- a. Make primary service application to Service Provider and receive approval for location, equipment, and design prior to installation of the service equipment.
- b. For underground service, furnish detailed drawings of the service conductor termination and metering sections for review and approval by Service Provider.
- c. Furnish, install, and maintain all service entrance facilities at the point of delivery including any equipment used to house Service Provider instrument metering transformers.
- d. Provide easements as applicable.
- e. Sign and return high voltage release document and all contracts.

6. SERVICE PROVIDER RESPONSIBILITIES

- a. Specify the location and voltage for point of delivery. Note: Service Provider distribution system may not be configured to provide the specific primary service requested by the Customer.
- b. Furnish, install, and maintain all primary service conductors and terminations up to the point of delivery.
- c. Furnish, install, and maintain the primary service and metering equipment in accordance with applicable rules, regulations, and rates.

 Tucson Electric Power	 UniSourceEnergy SERVICES SANTA CRUZ COUNTY	INITIATED BY	ES	REVISION NO.	6	SR-451 Pg. 1 of 10
		ESR COMM.	10-84	ESR COMM.	1-25	
				EFFECTIVE DATE	1-25	





PRIMARY METERED SERVICE

7. PROCESS TO ESTABLISH OVERHEAD PRIMARY SERVICE

- a. Customer submits application for new service with Service Provider Design Department.
- b. Service Provider specifies location of primary service.
- c. Customer provides any necessary easements to Service Provider.
- d. Customer installs point of service pole, anchor, disconnect, overhead slack span conductors and all related equipment as specified in the Technical Requirements section of this document.
- e. Customer notifies Service Provider that installation is complete.
- f. Service Provider Design Department inspects and approves Customer installation and releases work orders to install point of delivery pole, primary service line and meter termination cabinet.
- g. Service Provider line construction crew installs primary line to Company point of delivery pole and terminates Customer overhead slack span conductors. Crew also installs pole-mounted primary meter instrument transformer cluster. Primary service remains de-energized and grounded.
- h. Service Provider Metering Department completes metering wiring.
- i. Service Provider Design Department performs final inspection and releases the meter set order if all requirements are met.
- j. Service Provider Metering Department and Customer's electrical contractor meet on site to set the meter and energize the service.

8. TECHNICAL REQUIREMENTS - OVERHEAD PRIMARY SERVICE

- a. Point of service pole installation, including all required related material, shall be as shown in the construction drawing in Figure 1.
- b. Customer must guy and anchor point of service pole, install disconnect and provide customer owned overhead slack span conductors to attach at Company point of delivery pole.

 Tucson Electric Power	 UniSourceEnergy SERVICES <small>SANTA CRUZ COUNTY</small>	INITIATED BY	ES	REVISION NO.	5	SR-451 Pg. 2 of 10
		ESR COMM.	10-84	ESR COMM.	1-25	
			EFFECTIVE DATE	1-25		

USE: 7.97/13.8KV OR
2.4/4.16KV
PRIMARY SERVICE.

PRIMARY METERED SERVICE OVERHEAD-TO-OVERHEAD

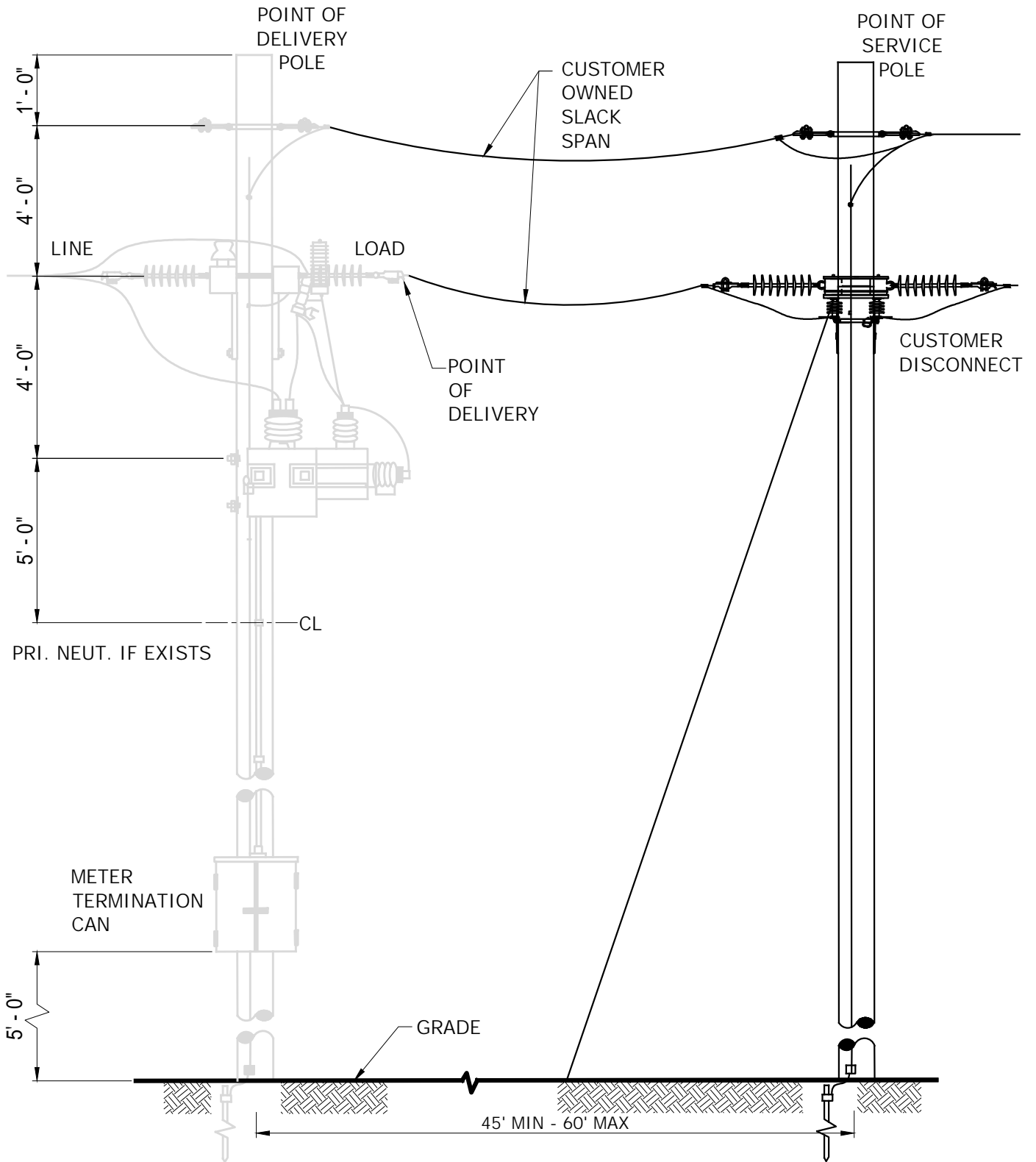

FIGURE 1

		INITIATED BY	ES	REVISION NO.	7	SR-451 Pg. 3 of 12
		ESR COMM.	10-84	ESR COMM.	10-24	
				EFFECTIVE DATE	1-25	



PRIMARY METERED SERVICE

9. PROCESS TO ESTABLISH UNDERGROUND PRIMARY SERVICE

- a. Customer submits application for new service with Service Provider Design Department.
- b. Service Provider specifies location of primary service.
- c. Customer provides any necessary easements to Service Provider.
- d. Customer submits drawings of primary service enclosure for review and approval by Service Provider. Drawings shall include equipment plan and elevation views of the external equipment and front and side internal elevation equipment views with dimensions. Switchgear manufacturer drawings are sufficient if they provide the required details.
- e. Customer provides and installs the switchgear and any necessary conduit from the Service Provider riser pole or pad-mount equipment to the primary service enclosure. Metering equipment will not be installed on a pole for an underground service, all metering equipment must be contained within the switchgear.
- f. Customer notifies Service Provider that installation is complete.
- g. Service Provider Design Department inspects and approves customer installation and releases work orders to install primary service line.
- h. Service Provider line construction crew terminates underground primary service cable (customer owned) from the designated Service Provider protective device to the primary service switchgear. Primary service remains de-energized and grounded.
- i. Service Provider Metering Department installs instrument transformers and meter wiring.
- j. Service Provider Design Department verifies completion of necessary Service Provider work and releases meter set work order.
- k. Service Provider Metering Department, Line Construction Department, and Customer's electrical contractor meet on site to set the meter and energize the service.

10. TECHNICAL REQUIREMENTS - UNDERGROUND PRIMARY SERVICE

- a. General
 Primary service enclosure shall be metal-clad switchgear built to the standards developed by EUSERC. Refer to Figure 2 below for specific dimensional information.
- b. Weatherproofing and Locking
 - Outdoor enclosures shall meet NEMA 3R and ANSI requirements.
 - Outdoor enclosures shall have a weatherproof outer door equipped with a three-point latching handle that can accommodate a Service Provider padlock.
 - Meter panel or door shall be hinged on the side opposite that of the weatherproof outer door to permit a 90 degree opening with the meter and test facilities in place.
 - The weatherproof outer door shall be equipped with a device to hold the door open to 90 degrees or more.
 - The weatherproof door may be omitted for equipment located indoors. In this case, the meter panel or door must be lockable.
- c. Ventilation Openings
 Ventilation openings shall be provided as per NEMA standard and shall be louvered or screened and guarded with internal barriers to prevent access to energized parts.

USE: Underground
 Primary Metering at
 2.4kV to 13.8kV

PRIMARY METERED SERVICE

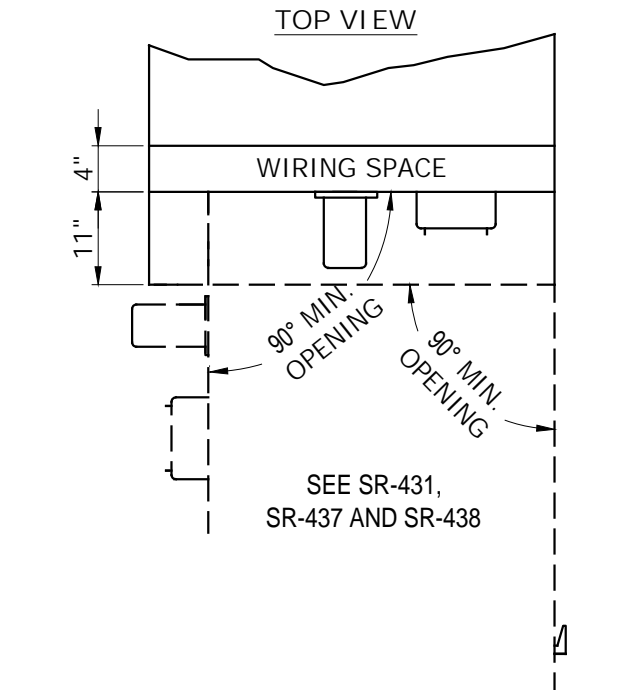

NOTES:
 RATING 14,400 V
 MINIMUM BARE BUS CLEARANCE Ø TO GROUND = 6"
 MINIMUM BARE BUS CLEARANCE Ø TO Ø = 7-1/2"

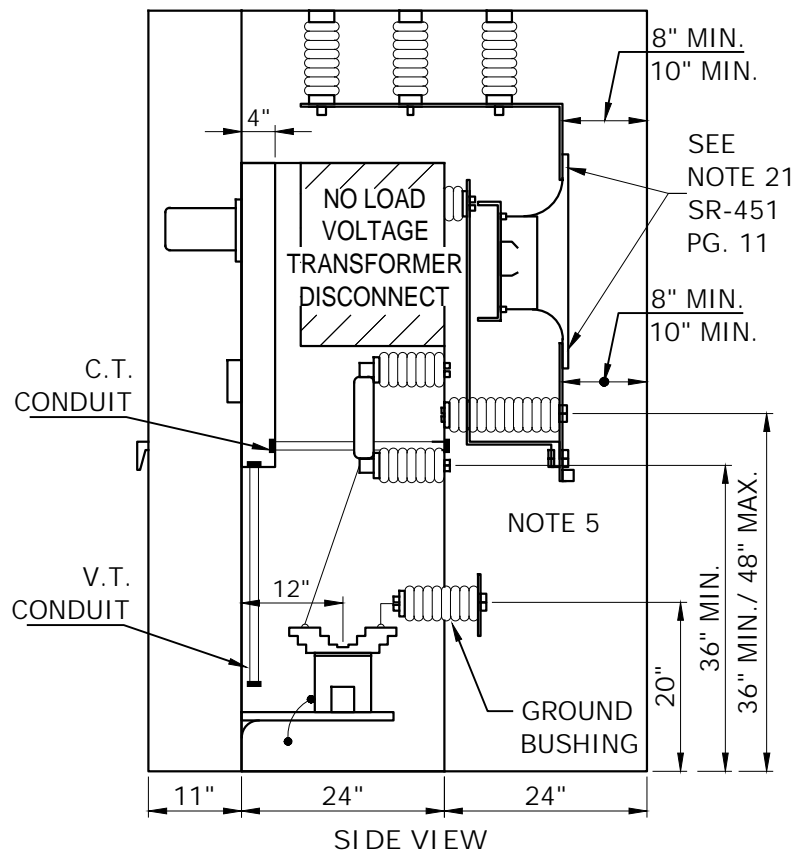
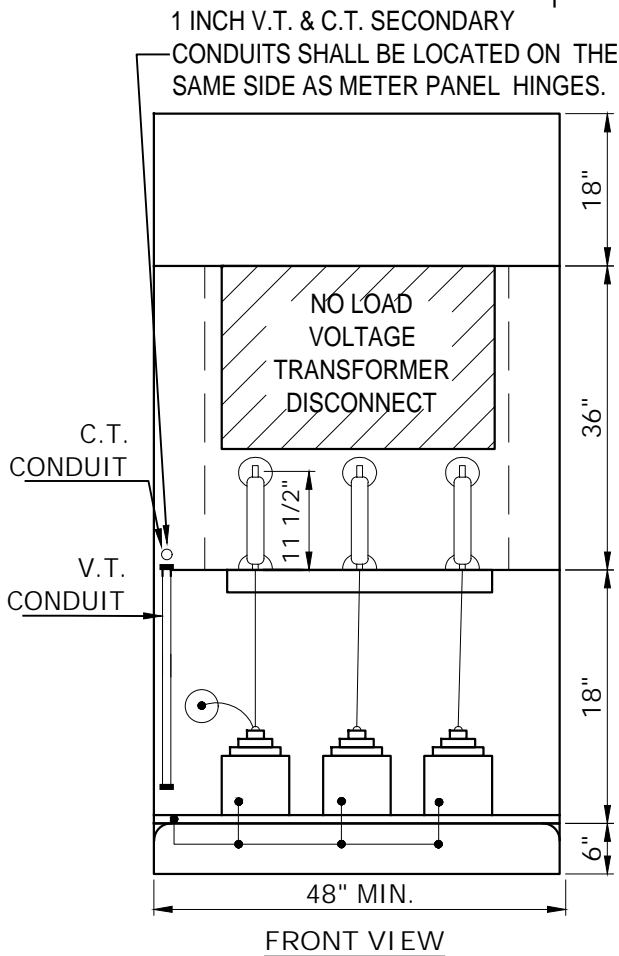

FIGURE 2



PRIMARY METERED SERVICE

10. TECHNICAL REQUIREMENTS - UNDERGROUND PRIMARY SERVICE (CONT.)

d. Working Space Around Primary Service Enclosures

Medium-voltage switchgear shall be installed with 5 feet of clear, level-standing, working space in the front, rear, or side of any section supporting or providing access to metering, testing equipment, or service cable termination sections.

e. Basic Impulse Level (BIL) Rating

BIL for the metering enclosure shall not be less than that for the customer's associated switchgear. Standard Service Provider voltages are three-phase 4.16kV, 13.2kV, and 13.8kV, depending on location. For 4.16kV primary service, equipment BIL shall be 60kV; for 13.2kV or 13.8kV primary service, equipment BIL shall be 95kV.

f. Service Cable Termination

- Underground service cable conduit shall enter the primary service enclosure from the bottom.
- One landing position shall be provided on each phase and neutral bus for each 400 amps, or portion thereof, of service ampacity.
- Two 1/2 inch steel bolts on 1-3/4 inch vertical centers shall be provided for each landing position, see Figure 3. These bolts, 2 inches in length, shall be provided with nuts, flat washers, and pressure maintaining spring washers. All parts shall be plated to prevent corrosion.

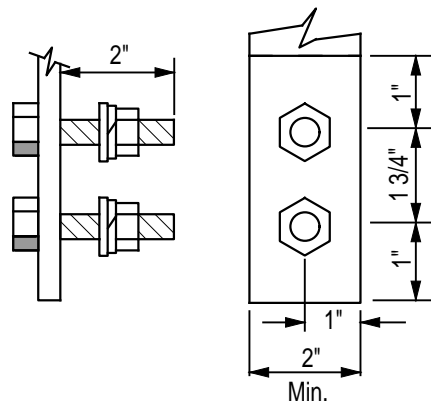

FIGURE 3
Landing Terminal Detail



PRIMARY METERED SERVICE

10. TECHNICAL REQUIREMENTS - UNDERGROUND PRIMARY SERVICE (CONT.)

g. Bus Bars and Conductors



- Only copper or plated aluminum bus shall be used in the metering and terminating enclosures. Aluminum bus shall be identified with the plating process where the service cables terminate and the current transformers are mounted.
- Maximum bus size shall be 3/8 inch by 4 inches; minimum bus size shall be 1/4 inch by 2 inches unless otherwise indicated on specific drawings.
- Bus installation for current transformers (CTs): When the main switch or circuit breaker enclosure is adjacent to and on the source side of the metering enclosure, connections from the load side of the main switch or circuit breaker to the line side of the current transformers shall be made using bus bars.
- Conductors passing through compartment walls: Where buses or conductors pass through compartment walls, through-the-wall bushings or insulated construction with full-voltage rating of the switchgear may be used.
- Vertical bus in the pull section and CT compartment shall be spaced 12-inches on centerlines between phases and the center phase shall be on the enclosure centerline.
- Bused thru-wall insulators for phase and neutral voltage transformer (VT) taps are to be furnished with lugs on the VT compartment side. Cables or bus conductors may be furnished for the taps to the fuse carriage and to the VT compartment, maintaining bare bus clearance.
- The neutral termination bus shall be insulated from the metering cubicle

h. Safety Grounding Provisions

Ball studs (1/2 inch-13 threads with insulating covers) for the attachment of Service Provider safety grounds shall be provided on the line and load side of the current transformer bus units. The studs shall be located no less than 7 inches from the end of the bus unit and oriented toward the compartment access opening.

i. Instrument Transformer Mounting Bases and Bus Links

- Voltage transformer (VT) and adjustable current transformer (CT) mounting platforms are to be provided by the manufacturer. Bus drilling and spacing shall accommodate the ampere rating of 15kV class CTs.
- VT mounting: The front or leading set of VT mounting holes shall be 9 inches from the VT compartment door.
- CT and bus link mounting: CT bus units shall be drilled and spaced to accept the current transformers of the proper rating and class and permit installation and removal of individual transformers without disturbing adjacent transformers. Center bus shall include a removable link dimensioned the same as the CT base on the metered phases. See Figure 4 for additional detail.
- Phase and neutral taps for fuses and VTs: Lugs for VT phase and neutral connections shall be provided in the VT compartment.
- VT fusing: Manufacturer shall provide mounting clips for indoor current-limiting fuses, nominal voltage rating 14,000V, current range 0.5 to 0.3 amps. The mounting clip separation shall be 11-1/2-inches on center, fuse ferrule diameter shall be 1-5/8-inches.
- Instrument transformer compartment or cabinet shall be used solely for Service Provider equipment. The compartment or cabinet shall not be used as a raceway for customer load conductors, other service conductors, or any other customer equipment.

 Tucson Electric Power	 SANTA CRUZ COUNTY	INITIATED BY	ES	REVISION NO.	5	SR-451 Pg. 7 of 10
		ESR COMM.	10-84	ESR COMM.	1-25	
				EFFECTIVE DATE	1-25	

USE: Underground
 Primary Metering at
 2.4kV to 13.8kV
 Indoor CT Dimensions



PRIMARY METERED SERVICE
 FIGURE 4

PRIMARY TERMINAL
 RATING - 800 AMPS.
 OR LESS.

PRIMARY TERMINAL
 OVER 800 AMPS.

9/16" DIA.

1/4" APPLIES TO MULTIPLE
 BAR THICKNESS. SINGLE
 BAR THICKNESS MAY BE
 FROM 3/16" TO 3/8".

NOTE:

INSULATION CLASSES ARE
 5, 8.7 AND 15KV. BASIC
 IMPULSE INSULATION
 LEVELS (BIL) FOR THESE
 CLASSES ARE 60, 75 AND
 110KV RESPECTIVELY.

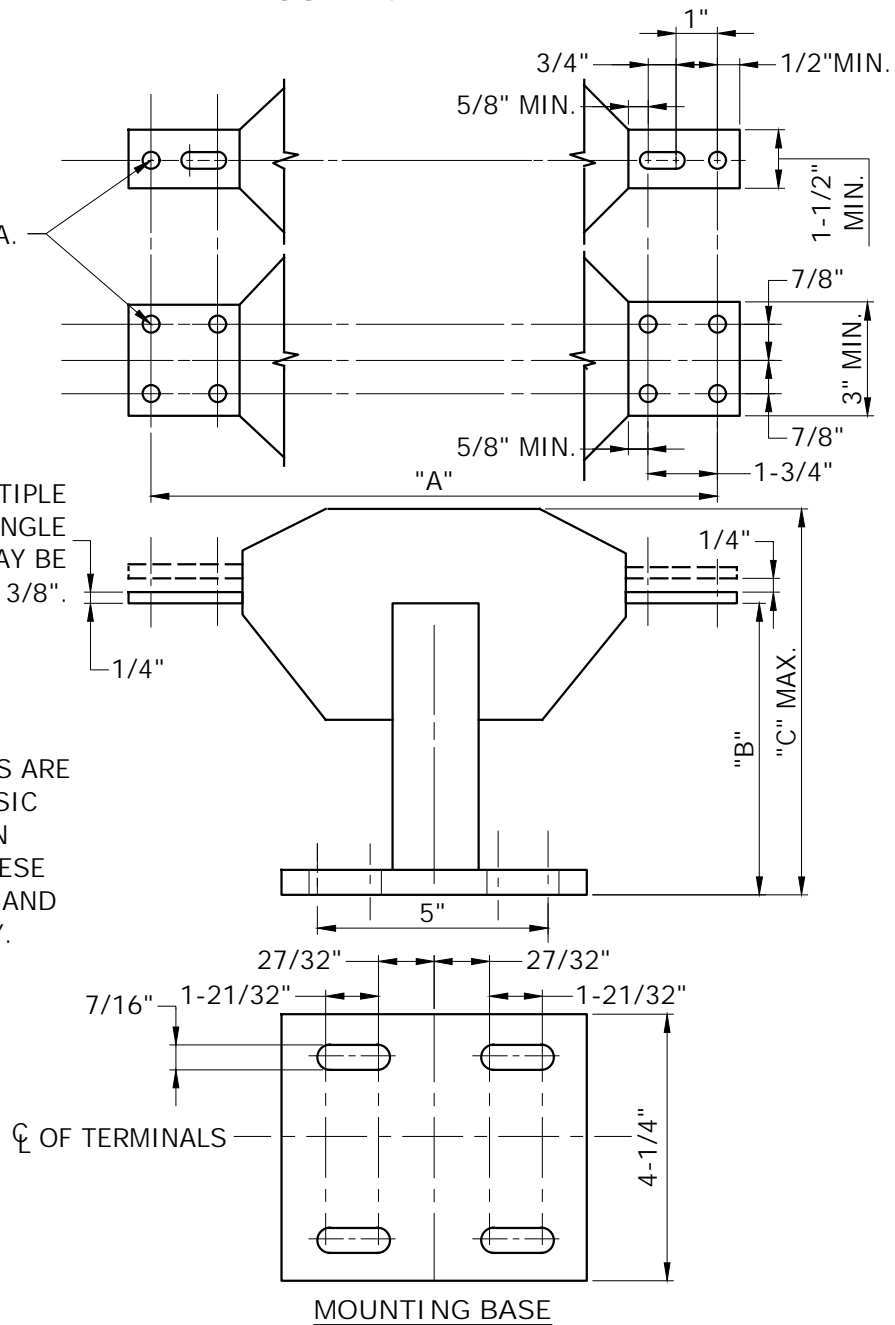

DIMENSIONS - INCHES*						
INSULATION CLASS kV	"A"		"B"		"C" (MAXIMUM)	
	AMPERES		AMPERES		AMPERES	
	10-800	1200-2000	10-800	1200-2000	10-800	1200-2000
5.0	14	-	5-3/4	-	8	-
8.7	15	-	8	-	10-1/2	-
15.0	22	26	9	5-3/4	11-1/4	13

* UNLESS OTHERWISE INDICATED TOLERANCE, PLUS OR MINUS 1/16 INCH.



PRIMARY METERED SERVICE

10. TECHNICAL REQUIREMENTS - UNDERGROUND PRIMARY SERVICE (CONT.)

j. VT Disconnect Requirements

- Kirk Key interlocking is required between the VT disconnect and the VT compartment door so that, for personnel safety, the VT compartment cannot be entered until the following conditions are met: (1) the disconnect is fully open and visibly grounded, (2) when the VT disconnect is fully open, the disconnect blades must ground automatically, and (3) the disconnect is locked open with a key interlock system.
- The interlock system must prevent closing of the disconnect without first closing and locking the VT compartment. Two keys shall be provided.
- Primary contacts for the VT disconnect shall be of the blade and jaw design or equivalent to assure continued adequate contact. Wiping contact or pressure contact is not acceptable.
- Operating handle or lever of the VT disconnect switch shall be padlockable in the closed position.
- VT disconnect shall be tapped on the supply side of the utility metering CTs.
- The VT compartment door shall provide unobstructed access to the VTs and fuses.
- VT disconnect shall have minimum voltage and BIL ratings equal to the equipment supplied.

k. Switchgear Metering Section

- Meter panel and hinges shall be designed to adequately support a 25-pound load applied to the unsupported end with 1/8 inch maximum sag when open. Bond meter door to switchgear enclosure with a #4 AWG flexible braided bond wire. Panel layout shall be as shown in EUSERC Drawing 408, see Figure 5.
- As an alternative, the meter panel may be mounted in front of the CT/Termination compartment, provided that when the meter panel is opened, the compartment is fully isolated by a removeable or hinged barrier.
- All external and internal doors providing access to the CT bus including the outer door, meter panel door, and hinged barrier shall be equipped with a device to hold them open at 90 degrees or more.
- Customer shall furnish and install a 13-terminal meter socket(s) designed for back connections. Customer shall also furnish and install a test switch (Superior Cat. No. 1058-F or exact equivalent) and a cover for the test switch (Superior Cat. No. 7943BC or exact equivalent). Note: the test switch and cover are not supplied by the switchgear manufacturer.

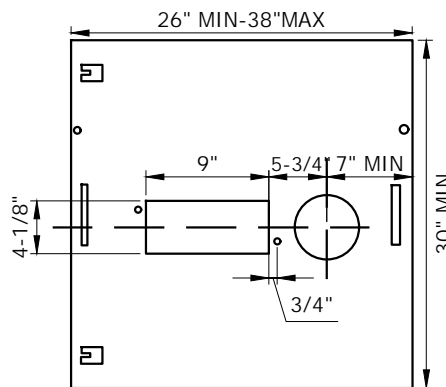

FIGURE 5

 Tucson Electric Power	 SANTA CRUZ COUNTY	INITIATED BY	ES	REVISION NO.	6	SR-451 Pg. 9 of 10
		ESR COMM.	10-84	ESR COMM.	1-25	
				EFFECTIVE DATE	1-25	



PRIMARY METERING

10. TECHNICAL REQUIREMENTS - UNDERGROUND PRIMARY SERVICE (CONT.)



i. Sealing of Metering and Pull Sections

Service termination pull sections and metering sections shall be fully enclosed. All hinged panels that will give access to these sections or to any secondary meter wiring shall be sealable. Bus ports through the side barriers of the metering section shall be closed with phenolic barriers or otherwise arranged to prevent access to the metering section.

m. Utility Compartment Labeling

Compartments of the metering enclosure shall be permanently labeled with machine engraved laminated phenolic (or equal) tags. Tags shall have 1/4 inch white letters and numbers on red colored material that is readily visible and mechanically attached to the face of the following designated compartment(s). In addition, each panel of the switchgear shall be labeled, using at least 1 inch white letters and numbers, stating the utility serving voltage, e.g., 13800Y/7900-volts or 4160Y/2400-volts.

- Utility voltage transformer (VT) compartment
- Utility voltage transformer (VT) fuse compartment
- Utility service termination compartment
- Utility metering panel.

		INITIATED BY	KR	REVISION NO.	8	SR-451 Pg. 10 of 10
		ESR COMM.	10-88	ESR COMM.	1-25	
				EFFECTIVE DATE	1-25	

USE: Reference list to purchase or stock approved metering service equipment

APPROVED METERING AND SERVICE EQUIPMENT



SUSPENSION OF APPROVED METER SELECTION

To support customers and suppliers in obtaining metering equipment during supply chain disruptions, the Company is temporarily suspending the requirement to purchase approved metering equipment on the SR-452, Pages 2-14.



A panel that is purchased for installation within the Company Service Territory must either be an approved panel as listed in SR-452 or match all panel requirements as shown on this page and within the 400 Section for the type of panel the customer will be installing. See SR-405 for additional details.

Guidelines for Metering Equipment

0 to 400 amp single and three phase services for self-contained meter enclosures (meter sockets only, all in ones, multi-packs and pedestals):

- Classified as EUSERC, UL and ANSI approved metering equipment
- AIC rating of 10,000 amps or greater. See SR-510 for specific AIC rating requirements.
- "A" base or "K" base meter sockets are not approved (bar type / bolted in meters are not allowed)
- All sockets will be ring types (ringless sockets not allowed)
- Dual rated enclosure for Overhead and Underground usage are required, except as noted
- All non-residential services shall have manual means of bypassing (not applicable for non-occupied services) so businesses will not be affected when maintenance is performed.
- Manual link bypasses (lever bypasses and automatic bypasses not allowed)
- Safety Sockets will be utilized on any 480 volt services
- Breakers used as main disconnecting devices rather than fuses when fault interrupting capabilities are in compliance.
- Fused equipment approved on a case by case basis for retrofits or where a main breaker disconnects fault interrupting ratings would be exceeded. Pull Out fused disconnects are not allowed.
- Multi-pack equipment with more than 4 sockets in height will not be accepted.
- 400 amp self-contained meter socket with manual link bypasses are for single phase only.
- Grounding must be made on the load-side of the metering equipment, not within the utility section. See Section 600 for details.
- Neutral terminal must be bonded to the enclosure. For details, see appropriate SR within Section 400 for type of service being installed.
- Panel shall be complete and will not be accepted with missing hardware. All hardware to be tightened to manufacturer's specifications.
- Equipment shall meet all requirements per SR-405.
- All equipment must be lockable and sealable.

This list of approved manufacturer's meter sockets is indicative of many types of equipment that are acceptable but is not an exhaustive list of all possible acceptable versions manufactured by a particular company. See the guidelines for selecting meter equipment. Customer's are encouraged to have Design Services review the panel specifications before purchase to ensure that the equipment meets all requirements. This will prevent the customer from having to replace the equipment after installation if it is found to be deficient for the required application and ensures a timely energization.

		INITIATED BY	GC	REVISION NO.	13	SR-452  Pg. 1 of 14
		ESR COMM.	10-06	ESR COMM.	4-23	
		ESR COMM.	10-06	EFFECTIVE DATE	5-23	

USE: Reference list to purchase or stock approved metering service equipment

APPROVED METERING AND SERVICE EQUIPMENT

TEP SR#	Type of Application	Size	Manufacturer	Catalog Number	Phase	Fault Rating	OH	UG	Terminals
SR-408	All-In-One	100	Eaton Cutler-Hammer	MBE1224B100BTF	1	10	X	X	4
SR-408	All-In-One	100	Eaton Cutler-Hammer	MBE1224B100BTS	1	10	X	X	4
SR-408	All-In-One	100	Eaton Cutler-Hammer	MBE1224B100TTS	1	10	X		4
SR-408	All-In-One	100	Eaton Cutler-Hammer	MBE1224PV100BTF	1	10	X	X	4
SR-408	All-In-One	100	Eaton Cutler-Hammer	MBE1224PV100BTS	1	10	X	X	4
SR-408	All-In-One	100	Eaton	MBE1224PVL100S ♣	1	10	X	X	4
SR-408	All-In-One	100	GE	TSM1610CSCU	1	22	X	X	4
SR-408	All-In-One	100	Siemens	MC1020B1100SZ	1	22	X		4
SR-408	All-In-One	100	Siemens	MC1224B1100EFC	1	22	X	X	4
SR-408	All-In-One	100	Siemens	MC1224B1100ESC	1	22	X	X	4
SR-408	All-In-One	100	Siemens	MC1224B1100FEC	1	22	X	X	4
SR-408	All-In-One	100	Siemens	MC1224B1100SEC	1	22	X	X	4
SR-408	All-In-One	100	Square D	SC1624M100F	1	10	X	X	4
SR-408	All-In-One	100	Square D	SC1624M100S	1	10	X	X	4
SR-408	All-In-One	100	Square D	SO1020M100S	1	10	X		4
SR-408	All-In-One	100	Square D	SO1020M100VP	1	10	X		4
SR-408	All-In-One	125	Eaton Cutler-Hammer	CMBE2222B125BF	1	10		X	4
SR-408	All-In-One	125	Eaton Cutler-Hammer	CMBE2222B125BS	1	10		X	4
SR-408	All-In-One	125	Eaton Cutler-Hammer	MBE1224B125BTF	1	10	X	X	4
SR-408	All-In-One	125	Eaton Cutler-Hammer	MBE1224B125BTS	1	10	X	X	4
SR-408	All-In-One	125	Eaton Cutler-Hammer	MBE1224PV125BTF	1	10	X	X	4
SR-408	All-In-One	125	Eaton Cutler-Hammer	MBE1224PV125BTS	1	10	X	X	4
SR-408	All-In-One	125	Eaton	MBE1224PVL125S ♣	1	10	X	X	4
SR-408	All-In-One	125	Eaton Cutler-Hammer	MBE2040PV125BTF	1	22	X	X	4
SR-408	All-In-One	125	GE	TSM1212CSCU	1	22	X	X	4
SR-408	All-In-One	125	Leviton	LP112-SR	1	22		X	4
SR-408	All-In-One	125	Leviton	LP312-SR	1	22		X	4
SR-408	All-In-One	125	Murray	JA1632B1125SEC	1	22	X	X	4
SR-408	All-In-One	125	Siemens	MC1224B1125EFC	1	22	X	X	4
SR-408	All-In-One	125	Siemens	MC1224B1125ESC	1	22	X	X	4
SR-408	All-In-One	125	Siemens	MC1224B1125FEC	1	22	X	X	4
SR-408	All-In-One	125	Siemens	MC1224B1125SEC	1	22	X	X	4
SR-408	All-In-One	125	Square D	SC1624M125F	1	10	X	X	4
SR-408	All-In-One	125	Square D	SC1624M125S	1	10	X	X	4
SR-408	All-In-One	150	Square D	SC816F150PS	1	22	X	X	4
SR-408	All-In-One	200	Eaton Cutler-Hammer	CMBE1212L200BF	1	10/22		X	4
SR-408	All-In-One	200	Eaton Cutler-Hammer	CMBE1212L200BS	1	10/22		X	4



INITIATED BY
ESR COMM.

GC
10-06

REVISION NO.
ESR COMM.
EFFECTIVE DATE

17
4-23
4-23

SR-452
Pg. 2 of 14

♣ New addition to the book.

USE: Reference list to purchase or stock approved metering service equipment

APPROVED METERING AND SERVICE EQUIPMENT

TEP SR#	Type of Application	Size	Manufacturer	Catalog Number	Phase	Fault Rating	OH	UG	Terminals
SR-408	All-In-One	200	Eaton Cutler-Hammer	CMBE1212L200TS	1	10/22	X		4
SR-408	All-In-One	200	Eaton Cutler-Hammer	CMBE24B200TSR	1	35	X		4
SR-408	All-In-One	200	Eaton Cutler-Hammer	CMBE4242B200BS2	1	35	X	X	4
SR-408	All-In-One	200	Eaton Cutler-Hammer	CMBE4242B200BTF	1	22	X	X	4
SR-408	All-In-One	200	Eaton Cutler-Hammer	CMBE4242B200BTS	1	22	X	X	4
SR-408	All-In-One	200	Eaton Cutler-Hammer	CMBE4242B200TS	1	35	X		4
SR-408	All-In-One	200	Eaton Cutler-Hammer	CMBE4242PV200BS	1	22	X	X	4
SR-408	All-In-One	200	Eaton Cutler-Hammer	CMBE4242PV200TS	1	22	X		4
SR-408	All-In-One	200	Eaton Cutler-Hammer	CMBE88B200BTF	1	22	X	X	4
SR-408	All-In-One	200	Eaton Cutler-Hammer	CMBE88B200BTS	1	22	X	X	4
SR-408	All-In-One	200	Eaton Cutler-Hammer	HP404040SHPVCSR	1	22		X	4
SR-408	All-In-One	200	Eaton Cutler-Hammer	HP404040SHPVBR	1	22		X	4
SR-408	All-In-One	200	Eaton Cutler-Hammer	MBE1212L200BF	1	10/22		X	4
SR-408	All-In-One	200	Eaton Cutler-Hammer	MBE1212L200BS	1	10/22		X	4
SR-408	All-In-One	200	Eaton Cutler-Hammer	MBE2040B200BTS	1	10		X	4
SR-408	All-In-One	200	Eaton Cutler-Hammer	MBE2040B200TS	1	10		X	4
SR-408	All-In-One	200	Eaton Cutler-Hammer	MBE2040PV200BTF	1	22		X	4
SR-408	All-In-One	200	Eaton Cutler-Hammer	MBE2040PV200BTS	1	22		X	4
SR-408	All-In-One	200	Eaton Cutler-Hammer	MBE4040B200BTF	1	22		X	4
SR-408	All-In-One	200	Eaton Cutler-Hammer	MBE4040B200BTS	1	22		X	4
SR-408	All-In-One	200	Eaton Cutler-Hammer	MBE4040B200TS	1	10		X	4
SR-408	All-In-One	200	Eaton Cutler-Hammer	MBE4040PV200BTF	1	22		X	4
SR-408	All-In-One	200	Eaton Cutler-Hammer	MBE4040PV200BTS	1	22		X	4
SR-408	All-In-One	200	Eaton Cutler-Hammer	MBE88B200BTF	1	10/22	X	X	4
SR-408	All-In-One	200	Eaton Cutler-Hammer	MBE88B200BTS	1	10/22	X	X	4
SR-408	All-In-One	200	GE	TSM2020CSCU	1	22	X	X	4
SR-408	All-In-One	200	GE	TSM2420UF42	1	22		X	4
SR-408	All-In-One	200	GE	TSM2420US42	1	22		X	4
SR-408	All-In-One	200	GE	TSM3220UFCU	1	22		X	4
SR-408	All-In-One	200	GE	TSM3220UWCU	1	22		X	4
SR-408	All-In-One	200	GE	TSM4020UWCU	1	22		X	4
SR-408	All-In-One	200	Leviton	LP320-SR ♣	1	22		X	4
SR-408	All-In-One	200	Leviton	LP420-SR ♣	1	22		X	4
SR-408	All-In-One	200	Murray	JAT121L1200FED	1	22		X	4
SR-408	All-In-One	200	Murray	JAT121L1200SED	1	22		X	4
SR-408	All-In-One	200	Murray	JC0406L1200H	1	22		X	4



⚡ Test - Bypass Equipped
 ♦ The Cat. Number is out of date & will be removed the following year to allow stock out.
 ⚡ The panel requires a HP40TFKIT kit to be purchased if this panel is to be served from overhead.
 ♣ New addition to the book.



INITIATED BY
 ESR COMM.

GC
 10-06

REVISION NO.
 ESR COMM.
 EFFECTIVE DATE

17
 11-22
 11-22

USE: Reference list to purchase or stock approved metering service equipment

APPROVED METERING AND SERVICE EQUIPMENT

TEP SR#	Type of Application	Size	Manufacturer	Catalog Number	Phase	Fault Rating	OH	UG	Terminals
SR-408	All-In-One	200	Siemens	MC0816B1200EST	1	22	X	X	4
SR-408	All-In-One	200	Siemens	MC0816B1200T ♣	1	22	X	X	4
SR-408	All-In-One	200	Siemens	MC0816S1200SCT	1	22	X	X	4
SR-408	All-In-One	200	Siemens	MC1212L1200FED	1	22		X	4
SR-408	All-In-One	200	Siemens	MC1212L1200SED	1	22		X	4
SR-408	All-In-One	200	Siemens	MC2040B1200EFC	1	22	X	X	4
SR-408	All-In-One	200	Siemens	MC2040B1200ESC	1	22	X	X	4
SR-408	All-In-One	200	Siemens	MC2040B1200F	1	22	X	X	4
SR-408	All-In-One	200	Siemens	MC2040B1200FED	1	22		X	4
SR-408	All-In-One	200	Siemens	MC2040B1200S	1	22	X	X	4
SR-408	All-In-One	200	Siemens	MC2040B1200SED	1	22		X	4
SR-408	All-In-One	200	Siemens	MC2040B1200SZ	1	22	X	X	4
SR-408	All-In-One	200	Siemens	MC2442B1200EFC	1	22	X	X	4
SR-408	All-In-One	200	Siemens	MC2442B1200ESC	1	22	X	X	4
SR-408	All-In-One	200	Siemens	MC2442B1200ESV	1	22	X	X	4
SR-408	All-In-One	200	Siemens	MC2442B1200FEC	1	22	X	X	4
SR-408	All-In-One	200	Siemens	MC2442S1200SEC	1	22	X	X	4
SR-408	All-In-One	200	Siemens	MC2442S1200FC	1	22	X	X	4
SR-408	All-In-One	200	Siemens	MC2442S1200SC	1	22	X	X	4
SR-408	All-In-One	200	Siemens	MC3040B1200SECW	1	22	X	X	4
SR-408	All-In-One	200	Siemens	MC3040S1200SC	1	22	X	X	4
SR-408	All-In-One	200	Siemens	MC3042B1200FED	1	22		X	4
SR-408	All-In-One	200	Siemens	MC3042B1200SED	1	22		X	4
SR-408	All-In-One	200	Square D	MC4040B1200SECW	1	22	X	X	4
SR-408	All-In-One	200	Siemens	MC4040S1200SC	1	22	X	X	4
SR-408	All-In-One	200	Square D	SC2040M200C	1	10	X	X	4
SR-408	All-In-One	200	Square D	SC2040M200F	1	22		X	4
SR-408	All-In-One	200	Square D	SC2040M200PS	1	22	X	X	4
SR-408	All-In-One	200	Square D	SC2040M200S	1	22	X	X	4
SR-408	All-In-One	200	Square D	SC3040M200F	1	22		X	4
SR-408	All-In-One	200	Square D	SC3040M200S	1	22	X	X	4
SR-408	All-In-One	200	Square D	SC3042M200PS	1	22	X	X	4
SR-408	All-In-One	200	Square D	SC40M200S	1	22	X	X	4
SR-408	All-In-One	200	Square D	SC40M200SA250LH	1	22	X	X	4



⚡ Test - Bypass Equipped
 ♦ The Cat. Number is out of date & will be removed the following year to allow stock out.
 ⚡ The panel requires a HP40TFKIT kit to be purchased if this panel is to be served from overhead.
 ♣ New addition to the book.



17

INITIATED BY
ESR COMM.

GC
10-06

REVISION NO.
ESR COMM.
EFFECTIVE DATE

17
11-22
11-22

SR-452
Pg. 4 of 14

USE: Reference list to purchase or stock approved metering service equipment

APPROVED METERING AND SERVICE EQUIPMENT

TEP SR#	Type of Application	Size	Manufacturer	Catalog Number	Phase	Fault Rating	OH	UG	Terminals
SR-408	All-In-One	200	Square D	SC42M200PS	1	22	X	X	4
SR-408	All-In-One	200	Square D	SC816F200PS	1	22	X	X	4
SR-408	All-In-One	200	Square D	SO2040M200S	1	22	X		4
SR-408	All-In-One	200	Square D	SO2040M200VP	1	22	X		4
SR-408	All-In-One	200	Square D	SU3040M200R	1	10		X	4
SR-408	All-In-One	200	Siemens	MC2040S1200SZ	1	22	X		4
SR-408	All-In-One	225	Leviton	LP422-SR ♣	1	22		X	4
SR-408	All-In-One	250	Siemens	MC0816B1200ESN	1	22	X	X	4
SR-412	All-In-One	300	Eaton Cutler-Hammer	HP304040SH ♪	1	22		X	4
SR-412	All-In-One	300	Siemens	MC3040MB21	1	22		X	4
SR-412	All-In-One	320	Milbank	M400-APS	1	10	X		4
SR-412	All-In-One	320	Milbank	U3251-0-200-CB	1	10		X	4
SR-412	All-In-One	400	Eaton Cutler-Hammer	CG1212P400BS	1	22		X	4
SR-412	All-In-One	400	Eaton Cutler-Hammer	CG403242SH ♪	1	22		X	4
SR-412	All-In-One	400	Eaton Cutler-Hammer	CG40SH ♪	1	22		X	4
SR-412	All-In-One	400	Eaton Cutler-Hammer	H816P400BS ♪	1	10/22		X	4
SR-412	All-In-One	400	Eaton Cutler-Hammer	H816P400BS (HPPR) ♪	1	10/22		X	4
SR-412	All-In-One	400	Eaton Cutler-Hammer	HP40 ♪	1	10/22		X	4
SR-412	All-In-One	400	Eaton Cutler-Hammer	HP40(HPPR) ♪	1	10/22		X	4
SR-412	All-In-One	400	Eaton Cutler-Hammer	HP402442 ♪	1	10/22		X	4
SR-412	All-In-One	400	Eaton Cutler-Hammer	HP404040SH ♪	1	10/22		X	4
SR-412	All-In-One	400	Eaton Cutler-Hammer	HP404040SHA ♪ ♥	1	10/22		X	4
SR-412	All-In-One	400	Eaton Cutler-Hammer	HP40SH ♪	1	10/22		X	4
SR-412	All-In-One	400	GE	TMH2440RMS	1	22		X	4
SR-412	All-In-One	400	GE	TSDA2440UC42	1	22		X	4
SR-412	All-In-One	400	Murray	JA0816B1400SCS ♥	1	22	X	X	4
SR-412	All-In-One	400	Murray	JA3042B1400SCS ♥	1	10	X	X	4
SR-412	All-In-One	400	Murray	JC0404L1400SCS ♥	1	22	X	X	4
SR-412	All-In-One	400	Siemens	MC2442B1400SD ♥	1	22		X	4
SR-412	All-In-One	400	Siemens	MC3040MB22	1	22		X	4
SR-412	All-In-One	400	Siemens	MC3042B1400FD	1	22		X	4
SR-412	All-In-One	400	Siemens	MC3042B1400SD	1	22		X	4
SR-412	All-In-One	400	Siemens	MC3042B1200SPV	1	22		X	4
SR-412	All-In-One	400	Siemens	MC3042S1400SC ♥	1	22	X	X	4



♪ The panel requires a HP40TFKIT kit to be purchased if this panel is to be served from overhead.
 ♣ New addition to the book.

♥ Test - Bypass Equipped
 ♦ The Cat. Number is out of date & will be removed the following year to allow stock out.



18

INITIATED BY
ESR COMM.

GC
10-06

REVISION NO.
ESR COMM.
EFFECTIVE DATE

18
11-22
11-22

SR-452
Pg. 5 of 14

USE: Reference list to purchase or stock approved metering service equipment

APPROVED METERING AND SERVICE EQUIPMENT

TEP SR#	Type of Application	Size	Manufacturer	Catalog Number	Phase	Fault Rating	OH	UG	Terminals
SR-412	All-In-One	400	Siemens	MC3042S1400FC	1	22	X	X	4
SR-412	All-In-One	400	Siemens	MC3042S1400SD	1	22		X	4
SR-412	All-In-One	400	Siemens	MC3042S1400FD	1	22		X	4
SR-412	All-In-One	400	Siemens	MC4040B14SD ♣	1	22		X	4
SR-412	Commercial Meter Main Combo	400	Siemens	MM0404L1400SCS ♥	1	22	X	X	4
SR-412	All-In-One	400	Square D	SU3040D400CN	1	25		X	4
SR-410	Commercial All-In-One	100	Milbank	U214MTBL	1	10	X	X	4
SR-410	Commercial All-In-One	100	Milbank	U217MTBL	3	10	X	X	7
SR-410	Commercial All-In-One	100	Murray	MM0202F1100CEY ♥	1	100	X	X	4
SR-410	Commercial All-In-One	100	Murray	MM0202L1100EY ♥	1	65	X		4
SR-410	Commercial All-In-One	100	Murray	MM0303F3100CEY ♥	3	100	X	X	7
SR-410	Commercial All-In-One	100	Murray	MM0303L3100EY ♥	3	65	X		7
SR-410	Commercial All-In-One	100	Siemens	MC1224B1100CESS ♥	1	10 to 65	X	X	4
SR-410	Commercial All-In-One	200	Milbank	U224MTBL	1	10	X	X	4
SR-410	Commercial All-In-One	200	Milbank	U227MTBL	3	10	X	X	7
SR-410	Commercial All-In-One	200	Murray	MM0202L1200CEY ♥	1	35	X	X	4
SR-410	Commercial All-In-One	200	Murray	MM0303F3200CEY ♥	3	100	X	X	7
SR-410	Commercial All-In-One	200	Murray	MM0303L3200CEY ♥	1	35	X	X	7
SR-410	Commercial All-In-One	200	Siemens	MC2440B1200CEY	1	10 to 22	X	X	4
SR-410	Commercial All-In-One	200	Siemens	MC2440B1200CESS ♥	1	10 to 65	X	X	4
SR-410	Commercial All-In-One	200	Talon	MM0202L1200CEY	1	35	X	X	4
SR-410	Commercial All-In-One	200	Talon	MM0202L1200EY	1	35	X		4
SR-412	Commercial All-In-One	320	Murray	BY1451GL ♥	1	22		X	4
SR-412	Commercial All-In-One	320	Murray	BY1455GL ♥	1	22		X	4
SR-412	Commercial All-In-One	320	Siemens	MC3040MB21SS ♥	1	22		X	4
SR-412	Commercial All-In-One	320	Siemens	MC3040MB22SS ♥	1	22		X	4
SR-412	Commercial All-In-One	400	Siemens	MC0816B1400SCS ♥	1	22	X	X	4
SR-412	Commercial All-In-One	400	Siemens	MC3042B1400SCS ♥	1	22	X	X	4
SR-412	Commercial All-In-One	400	Siemens	MC3042B1400SC	1	22	X	X	4
SR-410	Commercial Meter Main Combo	100	Cooper B-Line	U214MTB	1	10	X	X	4
SR-410	Commercial Meter Main Combo	100	Cooper B-Line	U215MTB	3	10	X	X	5
SR-410	Commercial Meter Main Combo	100	Cooper B-Line	U217MTB	3	10	X	X	7
SR-410	Commercial Meter Main Combo	100	Milbank	U214MTB	1	10	X	X	4
SR-410	Commercial Meter Main Combo	100	Milbank	U214MTB-48	1	14	X	X	4



♣ The panel requires a HP40TFKIT kit to be purchased if this panel is to be served from overhead.
 ♣ New addition to the book.

♥ Test - Bypass Equipped
 ♦ The Cat. Number is out of date & will be removed the following year to allow stock out.



INITIATED BY
 ESR COMM.

GC
 10-06

REVISION NO.
 ESR COMM.
 EFFECTIVE DATE

18
 11-22
 11-22

SR-452
 Pg. 6 of 14

USE: Reference list to purchase or stock approved metering service equipment

APPROVED METERING AND SERVICE EQUIPMENT

TEP SR#	Type of Application	Size	Manufacturer	Catalog Number	Phase	Fault Rating	OH	UG	Terminals
SR-410	Commercial Meter Main Combo	100	Milbank	U217MTB	3	10	X	X	7
SR-410	Commercial Meter Main Combo	100	Milbank	U217MTB-48	3	14	X	X	7
SR-410	Commercial Meter Main Combo	100	Siemens	MM0202L1100ESS ♡	1	10 to 100	X		4
SR-410	Commercial Meter Main Combo	100	Siemens	MM0202L3100ESS ♡	3	10 to 100	X		7
SR-410	Commercial Meter Main Combo	200	Cooper B-Line	U224MTB	1	10	X	X	4
SR-410	Commercial Meter Main Combo	200	Cooper B-Line	U225MTB	3	10	X	X	5
SR-410	Commercial Meter Main Combo	200	Cooper B-Line	U227MTB	3	10	X	X	7
SR-410	Commercial Meter Main Combo	200	Milbank	U224MTB	1	10	X	X	4
SR-410	Commercial Meter Main Combo	200	Milbank	U224MTB-48	1	14	X	X	4
SR-410	Commercial Meter Main Combo	200	Milbank	U227MTB	3	10	X	X	7
SR-410	Commercial Meter Main Combo	200	Milbank	U227MTB-48	3	14	X	X	7
SR-410	Commercial Meter Main Combo	200	Siemens	MM0202L1200CESS ♡	1	10 to 100	X	X	4
SR-410	Commercial Meter Main Combo	200	Siemens	MM0202L3200CESS ♡	3	10 to 100	X	X	7
SR-410	Commercial Meter Main Combo	200	Square D	EMT1225CB	1	100	X	X	5
SR-410	Commercial Meter Main Combo	200	Square D	EMT3225CB	1	100	X	X	7
SR-412	Commercial Meter Main Combo	400	Siemens	MM0404L1400SCS ♡	1	22	X	X	4
SR-418	Commercial Meter Pak	200	Myers/Ryco	WSM12-3	3	65		X	7
SR-410	Commercial Meter Main Combo	100	Cooper B-Line	114TB	1	100	X	X	4
SR-410	Commercial Meter Main Combo	100	Cooper B-Line	115TB	3	100	X	X	5
SR-410	Commercial Meter Main Combo	100	Cooper B-Line	117TB	3	100	X	X	7
SR-408	Commercial Meter Socket Only	100	Murray	MS14TB ♡	1	100	X	X	4
SR-408	Commercial Meter Socket Only	100	Murray	MS15TB ♡	3	100	X	X	5
SR-408	Commercial Meter Socket Only	100	Murray	MS17TB ♡	3	100	X	X	7
SR-410	Commercial Meter Socket Only	100	Siemens	MS14TB ♡	1	10 to 100	X	X	4
SR-410	Commercial Meter Socket Only	100	Siemens	MS15TB ♡	3	10 to 100	X	X	5
SR-410	Commercial Meter Socket Only	100	Siemens	MS17TB ♡	3	10 to 100	X	X	7
SR-410	Commercial Meter Socket Only	200	Cooper B-Line	124TB	1	22	X	X	4
SR-410	Commercial Meter Socket Only	200	Cooper B-Line	125TB	3	22	X	X	5
SR-410	Commercial Meter Socket Only	200	Cooper B-Line	127TB	3	22	X	X	7
SR-408	Commercial Meter Socket Only	200	Murray	MS24TB ♡	1	100	X	X	4
SR-408	Commercial Meter Socket Only	200	Murray	MS25TB ♡	3	100	X	X	5
SR-408	Commercial Meter Socket Only	200	Murray	MS27TB ♡	3	100	X	X	7
SR-410	Commercial Meter Socket Only	200	Siemens	MS24TB ♡	1	10 to 100	X	X	4



♣ The panel requires a HP40TFKIT kit to be purchased if this panel is to be served from overhead.
 ♣ New addition to the book.

♡ Test - Bypass Equipped
 ◆ The Cat. Number is out of date & will be removed the following year to allow stock out.



16

INITIATED BY
ESR COMM.

GC
4-07

REVISION NO.
ESR COMM.
EFFECTIVE DATE

16
11-22
11-22

SR-452
Pg. 7 of 14

USE: Reference list to purchase or stock approved metering service equipment

APPROVED METERING AND SERVICE EQUIPMENT

TEP SR#	Type of Application	Size	Manufacturer	Catalog Number	Phase	Fault Rating	OH	UG	Terminals
SR-410	Commercial Meter Socket Only	200	Siemens	MS25TB ♣	3	10 to 100	X	X	5
SR-410	Commercial Meter Socket Only	200	Siemens	MS27TB ♣	3	10 to 100	X	X	7
SR-410	Commercial Meter Socket Only	200	Eaton Cutler-Hammer	35SS120RAB ♣	3	100			5
SR-410	Commercial Meter Socket Only	200	Eaton Cutler-Hammer	35SS120RAC ♣	3	100			5
SR-410	Commercial Meter Socket Only	200	Eaton Cutler-Hammer	35SS120RBC ♣	3	100			5
SR-410	Commercial Meter Socket Only	200	Eaton Cutler-Hammer	35SS220RAB ♣	3	100			5
SR-410	Commercial Meter Socket Only	200	Eaton Cutler-Hammer	35SS220RAC ♣	3	100			5
SR-410	Commercial Meter Socket Only	200	Eaton Cutler-Hammer	35SS220RBC ♣	3	100			5
SR-410	Commercial Meter Socket Only	200	Eaton Cutler-Hammer	35SS320RAB ♣	3	100			5
SR-410	Commercial Meter Socket Only	200	Eaton Cutler-Hammer	35SS320RAC ♣	3	100			5
SR-410	Commercial Meter Socket Only	200	Eaton Cutler-Hammer	35SS320RBC ♣	3	100			5
SR-410	Commercial Meter Socket Only	200	Eaton Cutler-Hammer	37SS120R ♣	3	100			7
SR-410	Commercial Meter Socket Only	200	Eaton Cutler-Hammer	37SS220R ♣	3	100			7
SR-410	Commercial Meter Socket Only	200	Eaton Cutler-Hammer	37SS320R ♣	3	100			7
SR-418	Commercial Meter Socket Only	200	Square D	EZMT111225	1	100			4
SR-418	Commercial Meter Socket Only	200	Square D	EZMT112225	1	100			4
SR-418	Commercial Meter Socket Only	200	Square D	EZMT311225	3	100			5
SR-418	Commercial Meter Socket Only	200	Square D	EZMT312225	3	100			5
SR-418	Commercial Meter Socket Only	200	Square D	EZMT331225	3	100			7
SR-418	Commercial Meter Socket Only	200	Square D	EZMT332225	3	100			7
SR-409	Commercial Pedestal	100	Cooper B-Line	CMP4111MC-1	1	10	X	X	4
SR-409	Commercial Pedestal	100	Cooper B-Line	CMP4111MCH-1	1	10	X	X	4
SR-409	Commercial Pedestal	100	Cooper B-Line	CMP4411MC-1	3	10	X	X	7
SR-409	Commercial Pedestal	100	Cooper B-Line	CMP4411MCH-1	3	10	X	X	7
SR-409	Commercial Pedestal	100	Emerson	4PE24MEBRRY3MEZ1	1	42	X	X	4
SR-409	Commercial Pedestal	100	Emerson	4PE24MEBDERY3MEZ1	1	42	X	X	4
SR-409	Commercial Pedestal	100	Milbank	CP3B1115A22	1	22	X	X	4
SR-409	Commercial Pedestal	100	Milbank	CP3B1119A22	1	22	X	X	4
SR-409	Commercial Pedestal	100	Milbank	CP3B1119B22	1	22	X	X	4
SR-409	Commercial Pedestal	100	Milbank	CP3B11513A22	3	22	X	X	7
SR-409	Commercial Pedestal	100	Milbank	CP3B13115AW	1	10	X	X	4
SR-409	Commercial Pedestal	100	Myers/Ryco	MEUG16-M100	1	10	X	X	4
SR-409	Commercial Pedestal	100	Myers/Ryco	MEUG20-M100	1	10	X	X	4



♣ The panel requires a HP40TFKIT kit to be purchased if this panel is to be served from overhead.
 ♣ New addition to the book.

- ♥ Test - Bypass Equipped
- ◆ The Cat. Number is out of date & will be removed the following year to allow stock out.



17

INITIATED BY
ESR COMM.

GC
4-07

REVISION NO.
ESR COMM.
EFFECTIVE DATE

17
11-22
11-22

SR-452
Pg. 8 of 14

USE: Reference list to purchase or stock approved metering service equipment

APPROVED METERING AND SERVICE EQUIPMENT

TEP SR#	Type of Application	Size	Manufacturer	Catalog Number	Phase	Fault Rating	OH	UG	Terminals
SR-409	Commercial Pedestal	100	Myers/Ryco	MEUG24-PB-M100	1	10		X	4
SR-409	Commercial Pedestal	100	Myers/Ryco	MEUG26-060-CTV	1	22		X	4
SR-409	Commercial Pedestal	100	Myers/Ryco	MEUG35-PB-M100	1	10		X	4
SR-409	Commercial Pedestal	100	Myers/Ryco	MEUG35-UPS-M100	1	10		X	4
SR-409	Commercial Pedestal	100	Myers/Ryco	MEUG46-M100	1	10		X	4
SR-409	Commercial Pedestal	100	Pacific Utility Products	USP16-M2100-112CTB-TUC	1	10		X	4
SR-409	Commercial Pedestal	100	Strong Box	CSP-1116-10K	1	10		X	4
SR-409	Commercial Pedestal	100	TESCO	11-000	1	10		X	4
SR-409	Commercial Pedestal	100	TESCO	11-000	1 or 3	10		X	5
SR-409	Commercial Pedestal	100	TESCO	24-200	1	10		X	4
SR-409	Commercial Pedestal	100	TESCO	26-000	1	10		X	4
SR-409	Commercial Pedestal	100	TESCO	26-000	1 or 3	10		X	5
SR-409	Commercial Pedestal	100	TESCO	26-100	1	10		X	4
SR-409	Commercial Pedestal	100	TESCO	26-100	1 or 3	10		X	5
SR-409	Commercial Pedestal	100	TESCO	27-000	1	10		X	4
SR-409	Commercial Pedestal	100	TESCO	27-100	1	10		X	4
SR-409	Commercial Pedestal	100	TESCO	28-102	1	10		X	4
SR-409	Commercial Pedestal	100	TESCO	28-105	1	10		X	4
SR-409	Commercial Pedestal	125	ALPHA	UPE-M3	1	10		X	4
SR-409	Commercial Pedestal	125	ALPHA	UPE-M6	1	10		X	4
SR-409	Commercial Pedestal	125	ALPHA	UPE-M8	1	10		X	4
SR-409	Commercial Pedestal	125	Milbank	CP3B13115A22	1	22		X	4
SR-409	Commercial Pedestal	125	Myers/Ryco	MEUG16-M125-B2448-AZ	1	14		X	4
SR-409	Commercial Pedestal	125	Myers/Ryco	MEUG16-M200	1	10		X	4
SR-409	Commercial Pedestal	200	Cooper B-Line	CMP4121MC-1	1	10		X	4
SR-409	Commercial Pedestal	200	Cooper B-Line	CMP4121MCH-1	1	10		X	4
SR-409	Commercial Pedestal	200	Cooper B-Line	CMP4421MC-1	3	10		X	7
SR-409	Commercial Pedestal	200	Cooper B-Line	CMP4421MCH-1	3	10		X	7
SR-409	Commercial Pedestal	200	Milbank	CP3B12115A22	1	22		X	4
SR-409	Commercial Pedestal	200	Milbank	CP3B12119A22	1	22		X	4
SR-409	Commercial Pedestal	200	Milbank	CP3B12513A22	3	22		X	7
SR-409	Commercial Pedestal	200	Myers/Ryco	MEUG16-M125	1	10		X	4
SR-409	Commercial Pedestal	200	Myers/Ryco	MEUG16-M200-1220	3	42		X	7
SR-409	Commercial Pedestal	200	Myers/Ryco	MEUG16-M200-B2748	3	35		X	7
SR-409	Commercial Pedestal	200	Myers/Ryco	MEUG20-M200	1	10		X	4



⚠ The panel requires a HP40TFKIT kit to be purchased if this panel is to be served from overhead.
 ✦ New addition to the book.

♥ Test - Bypass Equipped
 ♦ The Cat. Number is out of date & will be removed the following year to allow stock out.



INITIATED BY
ESR COMM.

GC
4-07

REVISION NO.
ESR COMM.
EFFECTIVE DATE

17
11-22
11-22

SR-452
Pg. 9 of 14

USE: Reference list to purchase or stock approved metering service equipment

APPROVED METERING AND SERVICE EQUIPMENT

TEP SR#	Type of Application	Size	Manufacturer	Catalog Number	Phase	Fault Rating	OH	UG	Terminals
SR-409	Commercial Pedestal	200	Myers/Ryco	MEUG35-UPS-M200	1	10		X	4
SR-409	Commercial Pedestal	200	Myers/Ryco	MEUG46-M200	1	10		X	4
SR-409	Commercial Pedestal	200	Myers/Ryco	MEUG46-M200-2748	3	14		X	7
SR-409	Commercial Pedestal	200	TESCO	24-102	1 or 3	10		X	5
SR-409	Commercial Pedestal	200	TESCO	24-200	3	10		X	7
SR-409	Commercial Pedestal	200	TESCO	24-200	1 or 3	10		X	5
SR-409	Commercial Pedestal	200	TESCO	27-000	3	10		X	7
SR-409	Commercial Pedestal	200	TESCO	27-000	1 or 3	10		X	5
SR-409	Commercial Pedestal	200	TESCO	27-100	3	10		X	7
SR-409	Commercial Pedestal	200	TESCO	27-100	1 or 3	10		X	5
SR-409	Commercial Pedestal	200	TESCO	28-102	3	10		X	7
SR-409	Commercial Pedestal	200	TESCO	28-105	3	10		X	7
SR-409	Commercial Pedestal	200	TESCO	28-105	1 or 3	10		X	5
SR-408	Meter Main Combo	100	Cooper B-Line	1M1R	1	10	X		4
SR-408	Meter Main Combo	100	Cooper B-Line	1M1RF	1	10	X		4
SR-408	Meter Main Combo	100	Cooper B-Line	1M1RP	1	10	X		4
SR-408	Meter Main Combo	100	Cooper B-Line	1M1RPF	1	10	X		4
SR-408	Meter Main Combo	100	Cooper B-Line	U1M1R	1	10		X	4
SR-408	Meter Main Combo	100	Cooper B-Line	U1M1RF	1	10		X	4
SR-408	Meter Main Combo	100	Milbank	U3424-RL-100	1	10	X		4
SR-408	Meter Main Combo	100	Milbank	U3564-0-100	1	10		X	4
SR-408	Meter Main Combo	100	Siemens	MM0202B1100ESC	1	22	X	X	4
SR-408	Meter Main Combo	125	Eaton Cutler-Hammer	CMBE24L125BTF	1	10/22	X	X	4
SR-408	Meter Main Combo	125	Eaton Cutler-Hammer	CMBE24L125BTS	1	10/22	X	X	4
SR-408	Meter Main Combo	125	Eaton Cutler-Hammer	MBE24L125BTF	1	10	X	X	4
SR-408	Meter Main Combo	125	Eaton Cutler-Hammer	MBE24L125BTS	1	10	X	X	4
SR-408	Meter Main Combo	125	GE	TSL412CSCU	1	22	X	X	4
SR-408	Meter Main Combo	125	Siemens	MM0202L1125EFC	1	22	X	X	4
SR-408	Meter Main Combo	125	Siemens	MM0202L1125ESC	1	22	X	X	4
SR-408	Meter Main Combo	125	Siemens	MM0406L1125FEC	1	22	X	X	4
SR-408	Meter Main Combo	125	Siemens	MM0406L1125SEC	1	22	X	X	4
SR-408	Meter Main Combo	125	Square D	SC8L125S	1	10	X	X	4
SR-408	Meter Main Combo	150	Siemens	MM0202B1150	1	22	X		4
SR-408	Meter Main Combo	200	Cooper B-Line	2M25R	1	10	X		4
SR-408	Meter Main Combo	200	Cooper B-Line	2M25RF	1	10	X		4



⚠ The panel requires a HP40TFKIT kit to be purchased if this panel is to be served from overhead.
 ❁ New addition to the book.

♥ Test - Bypass Equipped
 ♦ The Cat. Number is out of date & will be removed the following year to allow stock out.



INITIATED BY
 ESR COMM.

GC
 4-07

REVISION NO.
 ESR COMM.
 EFFECTIVE DATE

17
 11-22
 11-22

SR-452
 Pg. 10 of 14

USE: Reference list to purchase or stock approved metering service equipment

APPROVED METERING AND SERVICE EQUIPMENT

TEP SR#	Type of Application	Size	Manufacturer	Catalog Number	Phase	Fault Rating	OH	UG	Terminals
SR-408	Meter Main Combo	200	Cooper B-Line	2M2RP	1	10	X		4
SR-408	Meter Main Combo	200	Cooper B-Line	2M2RPF	1	10	X		4
SR-408	Meter Main Combo	200	Cooper B-Line	U2M25R	3	10		X	4
SR-408	Meter Main Combo	200	Cooper B-Line	U2M2RP	1 or 3	10		X	4
SR-408	Meter Main Combo	200	Eaton Cutler-Hammer	CMBE24L200BTF	3	10/22	X	X	4
SR-408	Meter Main Combo	200	Eaton Cutler-Hammer	CMBE24L200BTS	1 or 3	10/22	X	X	4
SR-408	Meter Main Combo	200	Eaton Cutler-Hammer	CMBEB200BTF	3	22	X	X	4
SR-408	Meter Main Combo	200	Eaton Cutler-Hammer	CMBEB200BTS	1 or 3	22	X	X	4
SR-408	Meter Main Combo	200	Eaton Cutler-Hammer	MBE24L200BTF	3	10	X	X	4
SR-408	Meter Main Combo	200	Eaton Cutler-Hammer	MBE24L200BTS	1 or 3	10	X	X	4
SR-408	Meter Main Combo	200	Eaton Cutler-Hammer	MBEB200BTF	3	10	X	X	4
SR-408	Meter Main Combo	200	Eaton Cutler-Hammer	MBEB200BTS	1	10	X	X	4
SR-408	Meter Main Combo	200	GE	TSL420CSCU	1 or 3	22	X	X	4
SR-408	Meter Main Combo	200	Milbank	U3584-0-200	1	10		X	4
SR-408	Meter Main Combo	200	Siemens	MM0202B1200	1	22	X	X	4
SR-408	Meter Main Combo	200	Siemens	MM0202B1200ESC	1	22	X	X	4
SR-408	Meter Main Combo	200	Siemens	MM0202L1200EFC	1	22	X	X	4
SR-408	Meter Main Combo	200	Siemens	MM0202L1200ESC	1	22	X	X	4
SR-408	Meter Main Combo	200	Siemens	MM0406L1200FEC	1	22	X	X	4
SR-408	Meter Main Combo	200	Siemens	MM0406L1200SEC	1	22	X	X	4
SR-408	Meter Main Combo	200	Square D	SC12L200S	1	10	X	X	4
SR-408	Meter Main Combo	200	Square D	SC816F200F	1	22		X	4
SR-408	Meter Main Combo	200	Square D	SC816F200S	1	22	X	X	4
SR-412	Meter Main Combo	400	Square D	CUT2L400CN	1	25		X	4
SR-418	Meter Pak All-In-One	125	Eaton Cutler-Hammer	1MP3124R	1	10-42			4
SR-418	Meter Pak All-In-One	125	Eaton Cutler-Hammer	1MP4124R	1	10-42			4
SR-418	Meter Pak All-In-One	125	Eaton Cutler-Hammer	1MP5126R	1	10-42			4
SR-418	Meter Pak All-In-One	125	Eaton Cutler-Hammer	1MP6126R	1	10-42			4
SR-418	Meter Pak All-In-One	125	Siemens	WEP2211 w/NEMA Stud Kit	1	65	X	X	4
SR-418	Meter Pak All-In-One	125	Siemens	WEP3311 w/NEMA Stud Kit	1	65	X	X	4
SR-418	Meter Pak All-In-One	125	Siemens	WEP4411 w/NEMA Stud Kit	1	65	X	X	4
SR-418	Meter Pak All-In-One	125	Siemens	WEP4511 w/NEMA Stud Kit	1	65	X	X	4
SR-418	Meter Pak All-In-One	125	Siemens	WEP4611 w/NEMA Stud Kit	1	65	X	X	4
SR-418	Meter Pak All-In-One	125	Siemens	WEP5411 w/NEMA Stud Kit	1	65	X	X	4
SR-418	Meter Pak All-In-One	125	Siemens	WEP6511 w/NEMA Stud Kit	1	65	X	X	4



⚠ The panel requires a HP40TFKIT kit to be purchased if this panel is to be served from overhead.
 ❖ New addition to the book.

♥ Test - Bypass Equipped
 ♦ The Cat. Number is out of date & will be removed the following year to allow stock out.



18

INITIATED BY
 ESR COMM.

GC
 4-07

REVISION NO.
 ESR COMM.
 EFFECTIVE DATE

18
 11-22
 11-22

SR-452
 Pg. 11 of 14

USE: Reference list to purchase or stock approved metering service equipment

APPROVED METERING AND SERVICE EQUIPMENT

TEP SR#	Type of Application	Size	Manufacturer	Catalog Number	Phase	Fault Rating	OH	UG	Terminals
SR-418	Meter Pak All-In-One	125	Siemens	WEP6611 w/NEMA Stud Kit	1	65	X	X	4
SR-418	Meter Pak All-In-One	125	Square D	MP33125 w/Lug Kit MMSK2	1	42	X	X	4
SR-418	Meter Pak All-In-One	125	Square D	MP44125 w/Lug Kit MMSK2	1	42	X	X	4
SR-418	Meter Pak All-In-One	125	Square D	MP55125 w/Lug Kit MMSK2	1	42	X	X	4
SR-418	Meter Pak All-In-One	125	Square D	MP66125 w/Lug Kit MMSK2	1	42	X	X	4
SR-418	Meter Pak All-In-One	125	Square D	MP22125	1	42	X	X	4
SR-418	Meter Pak All-In-One	125	Eaton Cutler-Hammer	1MP2122R	1	10-42	X	X	4
SR-418	Meter Pak All-In-One	200	Eaton Cutler-Hammer	1MP2204R	1	10-42			4
SR-418	Meter Pak All-In-One	200	Eaton Cutler-Hammer	1MP3206R	1	10-42			4
SR-418	Meter Pak All-In-One	200	Eaton Cutler-Hammer	1MP4206R	1	10-42			4
SR-418	Meter Pak All-In-One	200	Eaton Cutler-Hammer	1MP5206R	1	10-42			4
SR-418	Meter Pak All-In-One	200	Eaton Cutler-Hammer	1MP6206R	1	10-42			4
SR-418	Meter Pak All-In-One	200	Siemens	WEP10612 w/NEMA Stud Kit	1	100	X	X	4
SR-418	Meter Pak All-In-One	200	Siemens	WEP4212 w/NEMA Stud Kit	1	100	X	X	4
SR-418	Meter Pak All-In-One	200	Siemens	WEP4312 w/NEMA Stud Kit	1	100	X	X	4
SR-418	Meter Pak All-In-One	200	Siemens	WEP4412 w/NEMA Stud Kit	1	100	X	X	4
SR-418	Meter Pak All-In-One	200	Siemens	WEP6412 w/NEMA Stud Kit	1	100	X	X	4
SR-418	Meter Pak All-In-One	200	Siemens	WEP6512 w/NEMA Stud Kit	1	100	X	X	4
SR-418	Meter Pak All-In-One	200	Siemens	WEP6612 w/NEMA Stud Kit	1	100	X	X	4
SR-418	Meter Pak All-In-One	200	Siemens	WEP8612 w/NEMA Stud Kit	1	100	X	X	4
SR-418	Meter Pak All-In-One	200	Square D	MP42200 w/Lug Kit MMSK2	1	22	X	X	4
SR-418	Meter Pak All-In-One	200	Square D	MP43200 w/Lug Kit MMSK2	1	22	X	X	4
SR-418	Meter Pak All-In-One	200	Square D	MP64200 w/Lug Kit MMSK2	1	22	X	X	4
SR-418	Meter Pak All-In-One	200	Square D	MP85200 w/Lug Kit MMSK2	1	22	X	X	4
SR-418	Meter Pak All-In-One	200	Square D	MP86200 w/Lug Kit MMSK2	1	22	X	X	4
SR-418	Meter Pak Modular	200	Eaton Cutler-Hammer	EZM113225	1	100			4
SR-418	Meter Pak Modular	125	Eaton Cutler-Hammer	1MM312R	1	42			4
SR-418	Meter Pak Modular	125	Eaton Cutler-Hammer	1MM312RC	1	42			4
SR-418	Meter Pak Modular	125	Eaton Cutler-Hammer	1MM412R	1	42			4
SR-418	Meter Pak Modular	125	Eaton Cutler-Hammer	1MM412RC	1	42			4
SR-418	Meter Pak Modular	125	Eaton Cutler-Hammer	3MM212R	3	42			7
SR-418	Meter Pak Modular	125	Eaton Cutler-Hammer	3MM212RC	3	42			7
SR-418	Meter Pak Modular	125	Eaton Cutler-Hammer	3MM312R	3	42			7
SR-418	Meter Pak Modular	125	Eaton Cutler-Hammer	3MM312RC	3	42			7
SR-418	Meter Pak Modular	125	Eaton Cutler-Hammer	3MM412R	3	42			7



⚡ Test - Bypass Equipped
 ♦ The Cat. Number is out of date & will be removed the following year to allow stock out.
 ⚡ The panel requires a HP40TFKIT kit to be purchased if this panel is to be served from overhead.
 ♦ New addition to the book.



17

INITIATED BY
ESR COMM.

GC
4-07

REVISION NO.
ESR COMM.
EFFECTIVE DATE

17
11-22
11-22

SR-452
Pg. 12 of 14

USE: Reference list to purchase or stock approved metering service equipment

APPROVED METERING AND SERVICE EQUIPMENT

TEP SR#	Type of Application	Size	Manufacturer	Catalog Number	Phase	Fault Rating	OH	UG	Terminals
SR-418	Meter Pak Modular	125	Eaton Cutler-Hammer	3MM412RC	3	42			7
SR-418	Meter Pak Modular	125	GE	TMM2212R	1				4
SR-418	Meter Pak Modular	125	GE	TMM4312R	1				4
SR-418	Meter Pak Modular	125	GE	TMM4412R	1				4
SR-418	Meter Pak Modular	125	Siemens	WMM21125	1	65	X	X	4
SR-418	Meter Pak Modular	125	Siemens	WMM22125J	1	65	X	X	4
SR-418	Meter Pak Modular	125	Siemens	WMM31125	1	65	X	X	4
SR-418	Meter Pak Modular	125	Siemens	WMM32125J	1	65	X	X	4
SR-418	Meter Pak Modular	125	Siemens	WMM41125	1	65	X	X	4
SR-418	Meter Pak Modular	125	Siemens	WMM42125J	1	65	X	X	5
SR-418	Meter Pak Modular	125	Square D	EZM113125	1	42			4
SR-418	Meter Pak Modular	125	Square D	EZM114125	1	42			4
SR-418	Meter Pak Modular	125	Square D	EZM313125	1	42			5
SR-418	Meter Pak Modular	125	Square D	EZM314125	1	42			5
SR-418	Meter Pak Modular	200	Eaton Cutler-Hammer	1MM320R	1	100			4
SR-418	Meter Pak Modular	200	Eaton Cutler-Hammer	1MM320RC	1	100			4
SR-418	Meter Pak Modular	200	Eaton Cutler-Hammer	1MM420R	1	100			4
SR-418	Meter Pak Modular	200	Eaton Cutler-Hammer	1MM420RC	1	100			4
SR-418	Meter Pak Modular	200	Eaton Cutler-Hammer	3MM220R	3	100			7
SR-418	Meter Pak Modular	200	Eaton Cutler-Hammer	3MM220RC	3	100			7
SR-418	Meter Pak Modular	200	Eaton Cutler-Hammer	3MM320R	3	100			7
SR-418	Meter Pak Modular	200	Eaton Cutler-Hammer	3MM320RC	3	100			7
SR-418	Meter Pak Modular	200	Eaton Cutler-Hammer	3MM420R	3	100			7
SR-418	Meter Pak Modular	200	GE	TMM4220R	1				4
SR-418	Meter Pak Modular	200	GE	TMM6320R	1				4
SR-418	Meter Pak Modular	200	GE	TMM6420R	1				4
SR-418	Meter Pak Modular	200	Siemens	WMM21225	1	100	X	X	4
SR-418	Meter Pak Modular	200	Siemens	WMM22225J	1	100	X	X	4
SR-418	Meter Pak Modular	200	Siemens	WMM31225	1	100	X	X	4
SR-418	Meter Pak Modular	200	Siemens	WMM32225J	1	100	X	X	5
SR-418	Meter Pak Modular	200	Siemens	WMM41225	1	100	X	X	4
SR-418	Meter Pak Modular	200	Siemens	WMM42225J	1	100	X	X	5
SR-418	Meter Pak Modular	200	Square D	EZM112225	1	100			4
SR-418	Meter Pak Modular	200	Square D	EZM114225	1	100			4



⚡ The panel requires a HP40TFKIT kit to be purchased if this panel is to be served from overhead.
 ♦ New addition to the book.

♥ Test - Bypass Equipped
 ♦ The Cat. Number is out of date & will be removed the following year to allow stock out.



18

INITIATED BY
ESR COMM.

GC
4-07

REVISION NO.
ESR COMM.
EFFECTIVE DATE

18
11-22
11-22

SR-452
Pg. 13 of 14

USE: Reference list to purchase or stock approved metering service equipment

APPROVED METERING AND SERVICE EQUIPMENT

TEP SR#	Type of Application	Size	Manufacturer	Catalog Number	Phase	Fault Rating	OH	UG	Terminals
SR-418	Meter Pak Modular	200	Square D	EZM312225	3	100			5
SR-418	Meter Pak Modular	200	Square D	EZM313225	3	100			5
SR-418	Meter Pak Modular	200	Square D	EZM314225	3	100			5
SR-418	Meter Pak Modular	225	Siemens	WMT11225 ♠	1	100	X	X	4
SR-418	Meter Pak Modular	225	Siemens	WMT12225J ♠	1	100	X	X	5
SR-418	Meter Pak Modular	225	Siemens	WMT13225J ♠	3	100	X	X	7
SR-418	Meter Pak Modular	225	Siemens	WMT21225 ♠	1	100	X	X	4
SR-418	Meter Pak Modular	225	Siemens	WMT22AB225J ♠	1	100	X	X	5
SR-418	Meter Pak Modular	225	Siemens	WMT22BC225J ♠	1	100	X	X	5
SR-418	Meter Pak Modular	225	Siemens	WMT22CA225J ♠	1	100	X	X	5
SR-418	Meter Pak Modular	225	Siemens	WMT23225J ♠	3	100	X	X	7
SR-418	Meter Pak Modular	225	Siemens	WMT31225 ♠	1	100	X	X	4
SR-418	Meter Pak Modular	225	Siemens	WMT32225J ♠	1	100	X	X	5
SR-418	Meter Pak Modular	225	Siemens	WMT33225J ♠	3	100	X	X	7
SR-410	Meter Socket Only	100	Milbank	1141B	1	200	X	X	4
SR-410	Meter Socket Only	100	Milbank	1171B	3	200	X	X	7
SR-410	Meter Socket Only	100	Milbank	U5929	1	10	X	X	4
SR-408	Meter Socket Only	200	Cooper B-Line	UG204	1	200		X	4
SR-408	Meter Socket Only	200	Cooper B-Line	UG204MSCD	1	200		X	4
SR-410	Meter Socket Only	200	Milbank	1241B	1	200	X	X	4
SR-410	Meter Socket Only	200	Milbank	1271B	3	200	X	X	7
SR-410	Meter Socket Only	200	Milbank	U3328-RXL	3	200	X	X	7
SR-408	Meter Socket Only	200	Milbank	U4518-XL-W	1	200	X	X	4
SR-408	Meter Socket Only	200	Milbank	RU4518-XL-W ♣	1	200	X	X	4
SR-412	Meter Socket Only	320	Cooper B-Line	324C	1	100		X	4
SR-412	Meter Socket Only	320	Milbank	U3548-X	1	10		X	4
SR-408	Pedestal	100	Cooper B-Line	M1M100PD	1	10		X	4
SR-408	Pedestal	100	Milbank	U5240-0-100S	1	10		X	4
SR-408	Pedestal	100	Milbank	U5241-0-100S	1	10		X	4
SR-408	Pedestal	125	Cooper B-Line	M1M125PD	1	10		X	4
SR-408	Pedestal	200	Cooper B-Line	M2M200PD	1	10		X	4
SR-408	Pedestal	200	Cooper B-Line	M2M200PPD	1	22		X	4
SR-408	Pedestal	200	Milbank	MPAP-200-MB-78 ♠	1	10		X	4
SR-408	Pedestal	200	Milbank	U5240-0-200S	1	10		X	4
SR-408	Pedestal	200	Milbank	U5241-0-200S	1	10		X	4
SR-412	Top Feed Kit for HP Units	400	Eaton Cutler-Hammer	HP40TFKIT	1		X		



♠ Test - Bypass Equipped
 ♦ The Cat. Number is out of date & will be removed the following year to allow stock out.
 ⚡ The panel requires a HP40TFKIT kit to be purchased if this panel is to be served from overhead.
 ♣ New addition to the book.



INITIATED BY
ESR COMM.

GC
10-09

REVISION NO.
ESR COMM.
EFFECTIVE DATE

10
11-22
11-22

**500 SECTION
SHORT CIRCUIT PROTECTION**

TITLE

Short Circuit Protection

SR-No.

510

SHORT CIRCUIT PROTECTION

The National Electrical Code, state, county and municipal codes and/or regulations require that service entrance equipment shall be suitable for the short-circuit current available at its supply terminals. It is the responsibility of the customer to install service entrance equipment and protection devices (fuses and/or circuit breakers) capable of interrupting and withstanding the available fault current.

Single-Phase Customer

For the purpose of equipment specification and permitting Service Provider will design its underground facilities so that the maximum fault current at the line terminals of the metering equipment will be limited to not exceed the following:



- Residential Services 200A or less - maximum AFC 10,000A UG. Except if the cable length is less than 45 feet when being served from a transformer. Then the AFC will be 22,000A.
- Residential Services 201A-400A - maximum AFC 22,000A UG only
- Residential Services 401A-800A - maximum AFC 42,000A UG only
- Commercial Services 400A or less - maximum AFC 22,000A (UG secondary minimum 45 feet in length)
- Commercial Services 800A or less - maximum AFC 42,000A (any length UnderGround secondary)
- Residential Services 200A or less - maximum AFC 10,000A OH*. Except when served from a 3 phase transformer bank. Contact Service Provider for fault current.
- Residential Services 201A-600A OH* - contact Service Provider for fault current.
- Commercial Services 600A or less OH* - contact Service Provider for fault current.

*OH is defined as any service that originates from Service Provider's overhead distribution system.

Due to the size and location of transformers and service conductors, the actual fault current may be lower than the values stated above. Upon request, Service Provider will calculate the actual available fault current.

Three-Phase Customer

For three-phase customers, Service Provider will determine the available fault current for each installation. The available fault current will be marked on switchgear plans and redline service layout drawing for specific projects. For three phase service from a pad mounted transformer, the fault current posted will be the available fault current at the secondary terminals of the transformer and will not take into account any reduction in fault current due to customer owned conductors. For three phase service from overhead transformers, the fault current posted will be at the point of delivery and will take into account the fault current reduction due to Service Provider owned secondary conductors but will not take into account any fault current reduction due to customer owned conductors.

		INITIATED BY	DC	REVISION NO.	9	SR-510 
		ESR COMM.	9-77	ESR COMM.	10-17	
						Pg. 1 of 2

SHORT CIRCUIT PROTECTION

Table 1 gives the available fault current for the size of customer's service entrance equipment installed. This chart has been published so that the customer can pre-order switchgear. However, care must be exercised in using this table, as it applies only when Service Provider is serving the customer's service entrance from an individual transformer which will be sized and installed for that load alone. Consult Service Provider for that decision.

TABLE 1 - AVAILABLE FAULT CURRENT BASED ON SIZE OF SERVICE ENTRANCE

SERVICE ENTRANCE EQUIPMENT CAPACITY (AMPS)	ASSUMED LOADING (AMPS) (80%)	MAXIMUM 3Ø FAULT CURRENT IN SYMMETRICAL AMPERES FOR SERVICE VOLTAGE LISTED				
		120/208V		120/240V	277/480V	
		POLE TYPE TRANSFORMER	PAD-MOUNT TRANSFORMER	POLE TYPE TRANSFORMER	POLE TYPE TRANSFORMER	PAD-MOUNT TRANSFORMER
200	160	13,900	13,900	12,100	12,100	12,100
400	320	20,900	27,800	18,100	24,100	24,100
600	480	27,800	55,600	31,900	35,500	32,600
800	640	36,800	55,600	42,500	35,500	32,600
1000	800	49,100	55,600	42,500		32,600
1200	960	77,400	75,100	67,00		32,600
1600	1280	77,400	75,100			32,600
2000	1600		75,100			32,600
2500	2000		75,100			52,300
3000	2400		75,100			52,300
4000	3200					52,300

600 SECTION GROUNDING AND BONDING

<u>TITLE</u>	<u>SR-No.</u>
General Information, Introduction, NFPA 70 NEC, Grounding, Bonding (Unfused Areas)	600
Minimum Size of Bonding/Equipment Grounding/Grounding Electrode Conductors and Grounding Bus	601
Concrete Encased Electrode (Ufer Ground)	602
Single Phase Meter Pedestal	603
Single Phase Overhead Residential Service (Meter Socket and Load Center)	604
Single Phase Overhead or Underground Service (All in One)	605
Single Phase Overhead or Underground (Multi-Pak Service)	606
Single or Three Phase Overhead Service(Meter Socket and Disconnects)	607
Three-Phase Service Overhead or Underground (Pull Section, Raceway and Sockets)	608
Transformer Rated Service With CT CAN Overhead or Underground	609
Transformer Rated Service Switchgear Overhead or Underground	610

USE: General Customer information for grounding and bonding

GENERAL INFORMATION

INTRODUCTION

TEP/UES recognizes the value of the NEC Grounding and Bonding requirements. We are pleased to share the following illustrations and data applicable to the requirements.

This information will provide assistance and guidance to person's installing Service Entrance equipment in areas served by TEP/UES.

The methods of Grounding and Bonding of Service Entrance equipment shown in this manual are recommended to maintain consistency throughout our service territory.

The following drawings and tables will assist in assuring a safe and adequate grounding installation, acceptable under any code. Please consult your local governmental agency that has provided you with a permit for all applicable codes within their jurisdiction.

NFPA 70 NEC

1. Customer wire shall not be run through utility sealed areas.
2. Weatherproof hubs, etc., shall be used on any penetrations of equipment at the same height or above energized areas. A good rule of thumb is; that unless the penetration is on the bottom surface of a can, it shall be done with a weatherproof connection. Indoor equipment is an exception to this requirement.
3. Bonding hubs (Meyers or equivalent) shall not be used on multi-centric knockouts, unless the largest knockout is used.
4. Interior metal water piping systems, complying with NEC requirements are permitted for grounding and shall be bonded to the service entrance enclosure with conductors sized per NEC. In multiple occupancy buildings where the interior metal water piping system for the individual occupancies is isolated from all other occupancies by the use of non-metallic pipe, each water system may be bonded to the panel board or switchboard enclosure supplying that occupancy, sized per NEC.
5. Other metal piping systems (e.g. gas pipe) shall be bonded to the service equipment enclosure with a conductor sized per NEC.
6. Nonconductive paint must be removed at threads, contact points and contact surfaces of any ground/bond lugs, terminal strips, etc., to assure a good electrical connection.

GROUNDING



The grounding electrode conductor may be either bare or with green insulation. Ground electrode conductors not encased in conduit shall be a minimum size of No. 4 copper or larger and must be securely fastened to the building or structure with approved fastening devices. The spacing of such devices shall not exceed 2 feet. If a ground rod is used as an electrode, they shall be at least 6 feet apart and at least 8 feet shall be in contact with the soil.

Grounding Electrode conductors smaller than size No. 4 copper shall be solid copper wire, or shall be attached to the ground rod using the exothermic welding process.

BONDING (UNFUSED AREA)

Bonding is required on all enclosures, equipment, raceways, and fittings which contain unfused service conductors. Nipples and bushings installed through eccentric or concentric knockouts must be bonded with ground bushings, wedges, or other approved devices. Bond conductor size shall be per NEC.

FORMALLY: SR-453 Page 2

		INITIATED BY	DM	REVISION NO.	0	SR-600 Pg. 1 of 1
		ESR COMM.	7-17	ESR COMM.	-	
		ESR COMM.	7-17	EFFECTIVE DATE	7-17	

USE: General Customer information for grounding and bonding.

**MINIMUM SIZE OF BONDING,
EQUIPMENT GROUNDING,
GROUNDING ELECTRODE CONDUCTORS
AND GROUND BUS**

TABLE 250.122 Minimum Size Equipment Grounding Conductors for Grounding Raceway and Equipment		
Rating or Setting of Automatic Overcurrent Device in Circuit Ahead of Equipment, Conduit, etc., Not Exceeding (Amperes)	Copper	Aluminum or Copper-Clad Aluminum
15	14	12
20	12	10
30	10	8
40	10	8
60	10	8
100	8	6
200	6	4
300	4	2
400	3	1
500	2	1/0
600	1	2/0
800	1/0	3/0
1000	2/0	4/0
1200	3/0	250
1600	4/0	350
2000	250	400
2500	350	600
3000	400	600
4000	500	800
5000	700	1200
6000	800	1200
Size (AWG or kcmil)		

NOTES:

1. For sizing bonding conductor for gas line, per NEC 250.014.
2. For sizing any bond conductor required on the load side of fuses or circuit breakers per NEC 250.102.



FORMALLY: SR-453 Pg. 3

USE: General Customer information for grounding and bonding.

**MINIMUM SIZE OF BONDING,
EQUIPMENT GROUNDING,
GROUNDING ELECTRODE CONDUCTORS
AND GROUND BUS**

TABLE 250.66 Grounding Electrode Conductor for Alternating Current System			
Size of Largest Underground Service - Entrance Conductor or Equivalent Area for Parallel Conductors (AWG/kcmil)		Size of Grounding Electrode Conductor (AWG/kcmil)	
Copper	Aluminum or Copper-Clad Aluminum	Copper	Aluminum or Copper-Clad Aluminum
2 or smaller	1/0 or smaller	8	6
1 or 1/0	2/0 or 3/0	6	4
2/0 or 3/0	4/0 or 250	4	2
Over 3/0 through 350	Over 250 through 500	2	1/0
Over 350 through 600	Over 500 through 900	1/0	3/0
Over 600 through 1100	Over 900 through 1750	2/0	4/0
Over 1100	Over 1750	3/0	250

Review the notes below this table and in the NEC

NOTES:

1. For metal water pipe bonding refer to the NEC 250.104
2. For sizing main bonding jumper from equipment grounding bus to neutral bus refer to the NEC 250.28.
3. Where exposed, a grounding electrode conductor or its enclosure shall be securely fastened to the surface on which it is carried. A #4 AWG or larger copper or aluminum grounding electrode conductor shall be protected where exposed to physical damage. A #6 AWG grounding electrode conductor that is free from exposure to physical damage shall be permitted to be run along the surface of the building construction without metal covering or protection where it is securely fastened to the construction; otherwise, it shall be in rigid metal conduit, intermediate metal conduit, rigid nonmetallic conduit, electrical metallic tubing, or cable armor. Grounding electrode conductors smaller than #6 AWG shall be in rigid metal conduit, intermediate metal conduit, rigid nonmetallic conduit, electrical metallic tubing, or cable armor. Refer to the NEC 250.64



FORMALLY: SR-453 Pg. 4

USE: GENERAL CUSTOMER
INFORMATION FOR
GROUNDING AND BONDING

CONCRETE ENCASED ELECTRODE (UFER GROUND)

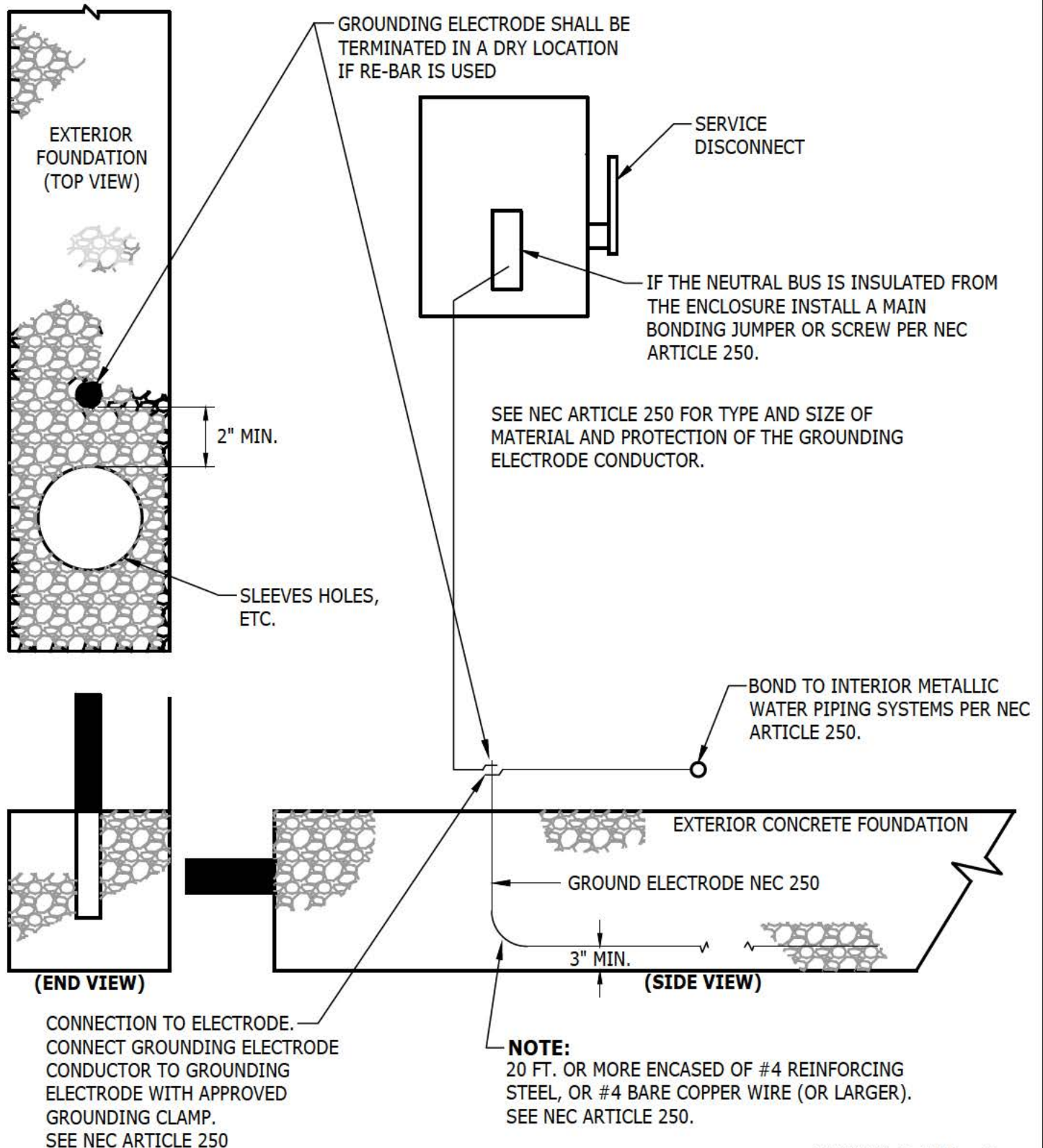

FORMALLY: SR-453 Page 5

USE: GENERAL CUSTOMER INFORMATION FOR GROUNDING AND BONDING

SINGLE PHASE OVERHEAD RESIDENTIAL SERVICE (METER SOCKET & LOAD CENTER)

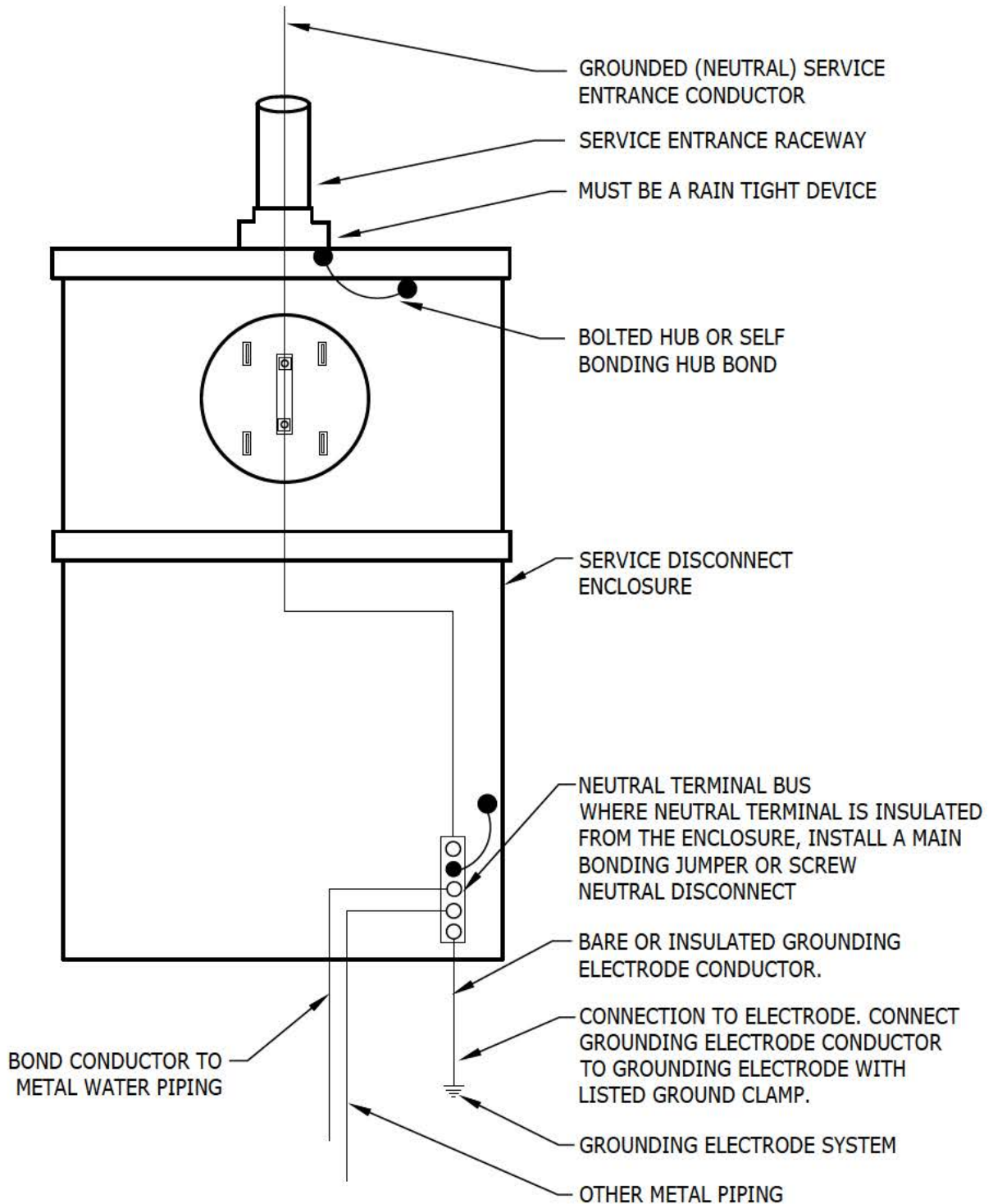

SEE NEC ARTICLE 250 FOR REFERENCE.

FORMALLY: SR-453 Page 8

USE: GENERAL CUSTOMER INFORMATION FOR GROUNDING AND BONDING

SINGLE PHASE OVERHEAD OR UNDERGROUND SERVICE (ALL IN ONE)

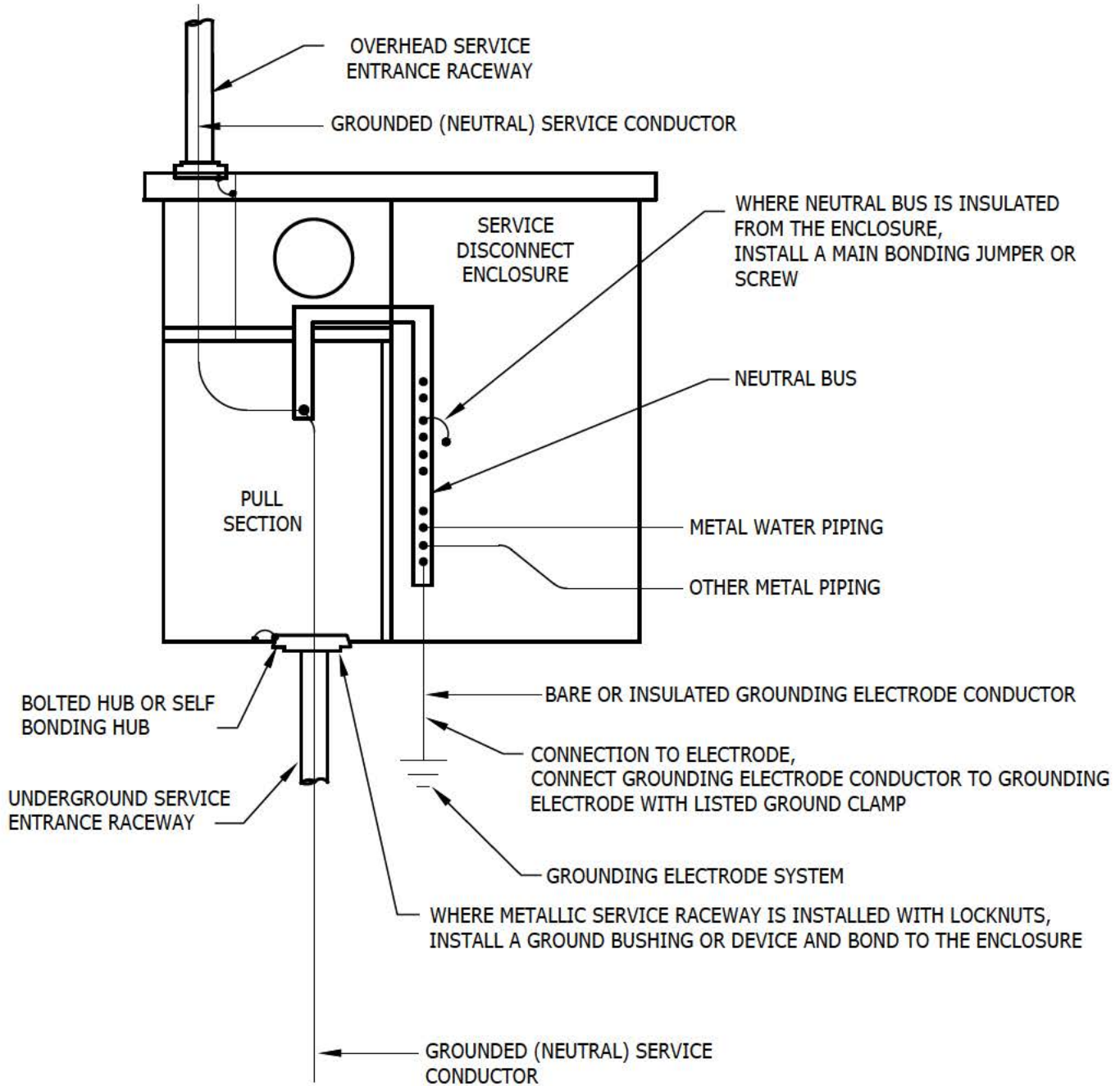

SEE NEC ARTICLE 250 FOR REFERENCE.

FORMALLY: SR-453 Page 9

USE: GENERAL CUSTOMER INFORMATION FOR GROUNDING AND BONDING

SINGLE PHASE OVERHEAD OR UNDERGROUND (MULTI-PAK SERVICE)

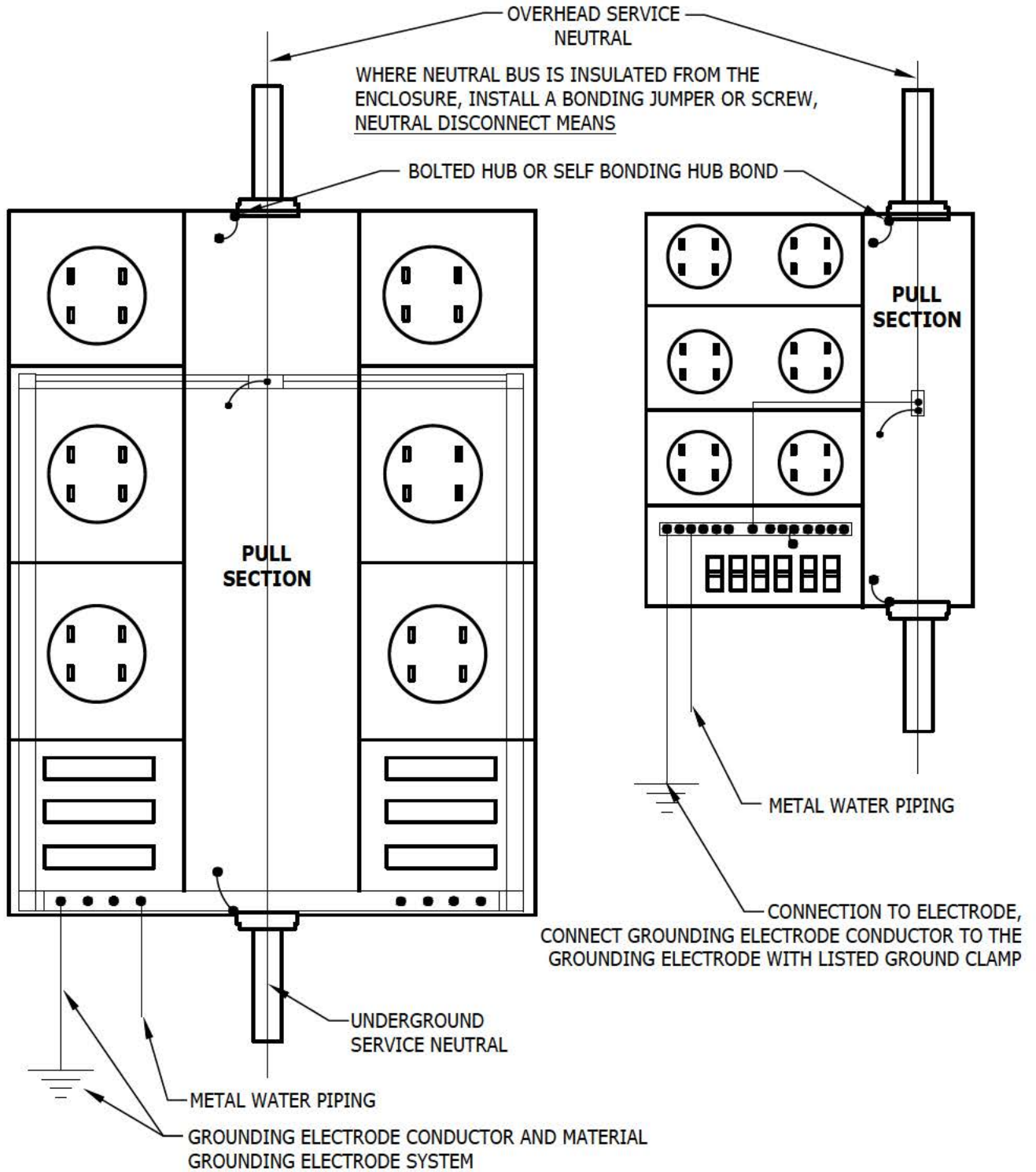

SEE NEC ARTICLE 250 FOR REFERENCE.

FORMALLY: SR-453 Page 10

USE: GENERAL CUSTOMER INFORMATION FOR GROUNDING AND BONDING

SINGLE OR THREE PHASE OVERHEAD RESIDENTIAL SERVICE (METER SOCKET AND DISCONNECTS)

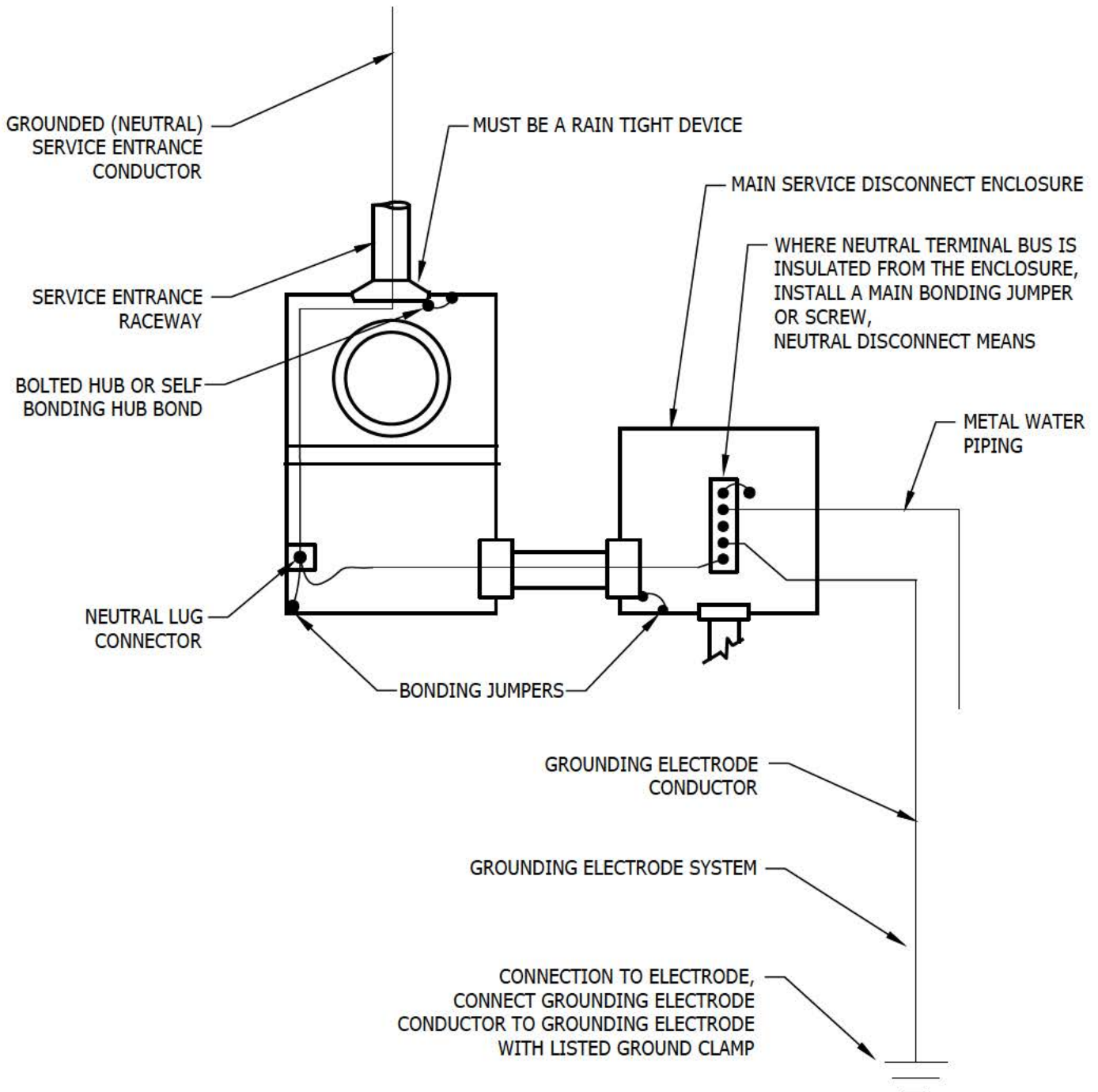

SEE NEC ARTICLE 250 FOR REFERENCE.

FORMALLY: SR-453 Page 7

USE: GENERAL CUSTOMER
INFORMATION FOR
GROUNDING AND
BONDING

THREE PHASE OVERHEAD OR UNDERGROUND SERVICE (PULL SECTION, RACEWAY & SOCKETS)

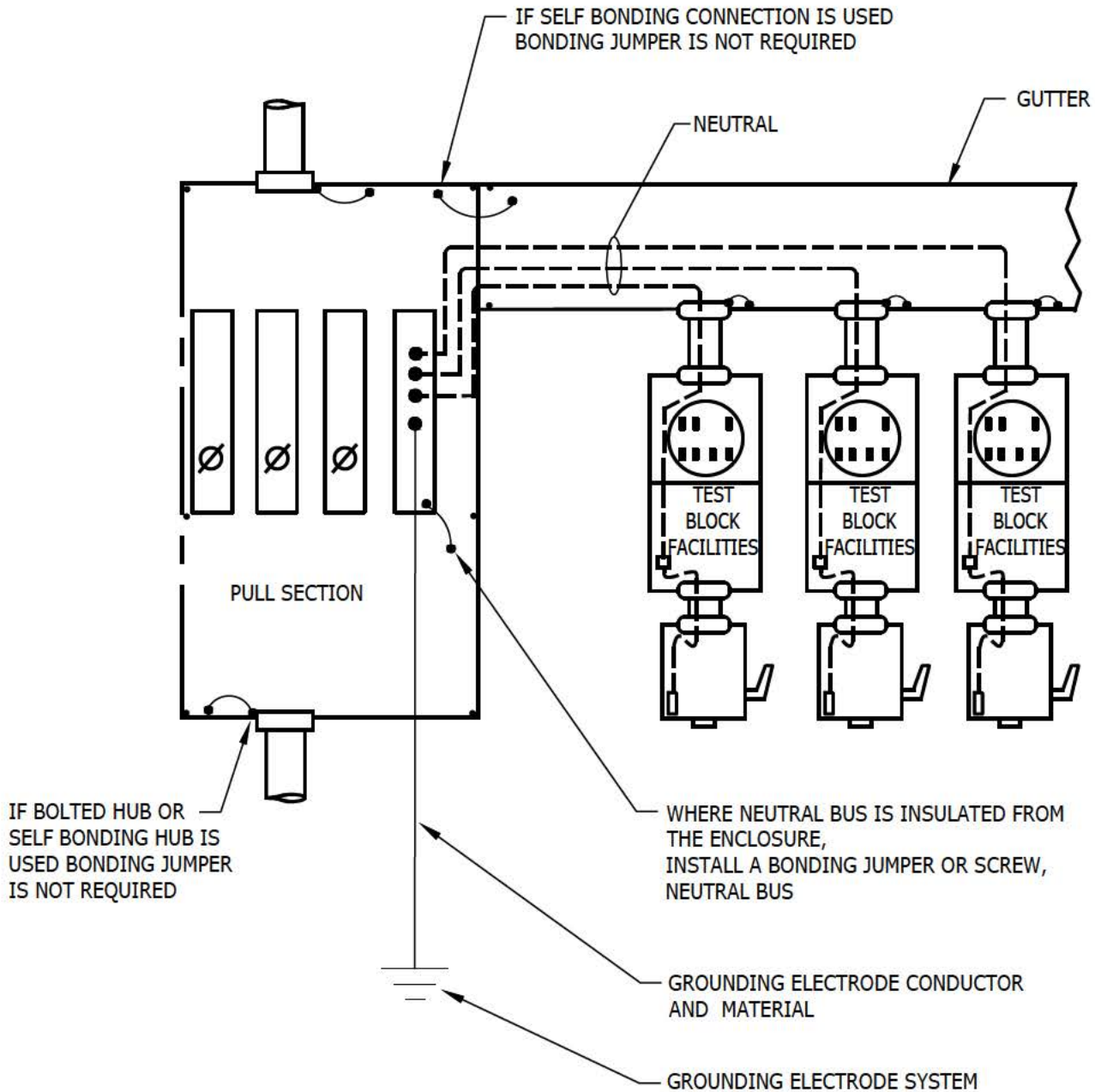

SEE NEC ARTICLE 250 FOR REFERENCE.

FORMALLY: SR-453 Page 11

USE: GENERAL CUSTOMER INFORMATION FOR GROUNDING AND BONDING

TRANSFORMER RATED OVERHEAD OR UNDERGROUND SERVICE WITH CT CAN

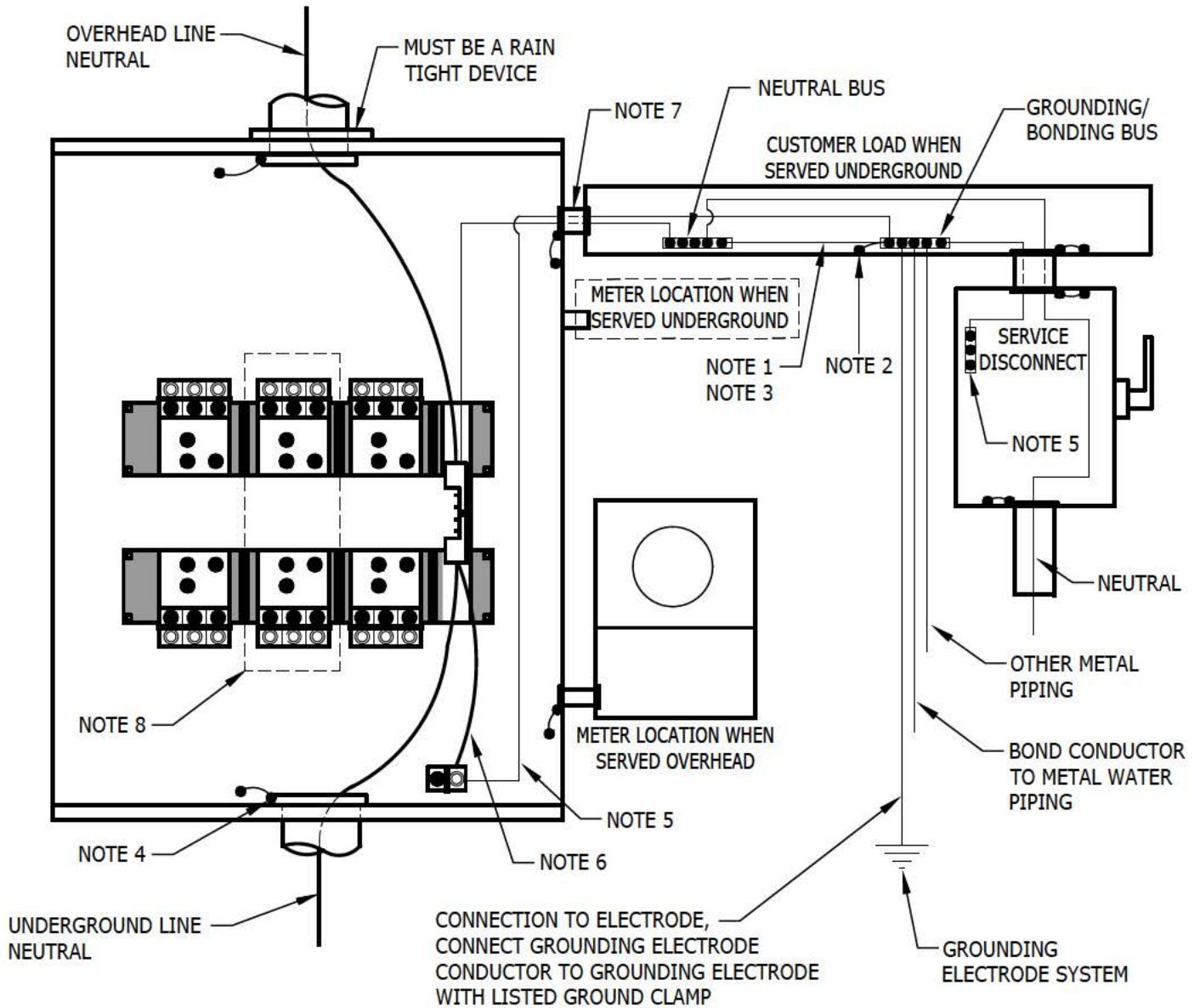

NOTES:

1. MAIN BONDING JUMPER REQUIRED PER NEC.
2. GROUNDING BOND BUS TO BE TIED TO METAL GUTTER.
3. BOND CONDUCTOR SIZED PER THE NEC.
4. IF BOLTED HUB OR SELF BONDING HUB IS USED BONDING JUMPER IS NOT REQUIRED.
5. BOND TERMINAL BAR TO BE TIED TO THE METAL ENCLOSURE.
6. NEUTRAL TERMINAL SHALL BE BONDED TO THE CT CAN.
7. IF PARALLEL CONDUCTORS RUN FROM THE CAN INTO THE GUTTER, A BOND WIRE MUST BE INSTALLED IN EACH CONDUIT PER THE NEC.
8. MIDDLE BUS IS NOT PRESENT ON A SINGLE PHASE INSTALLATION.

SEE NEC ARTICLE 250 FOR REFERENCE.

FORMALLY: SR-453 Page 12

USE: GENERAL CUSTOMER INFORMATION FOR GROUNDING AND BONDING

TRANSFORMER RATED OVERHEAD OR UNDERGROUND SERVICE SWITCHGEAR

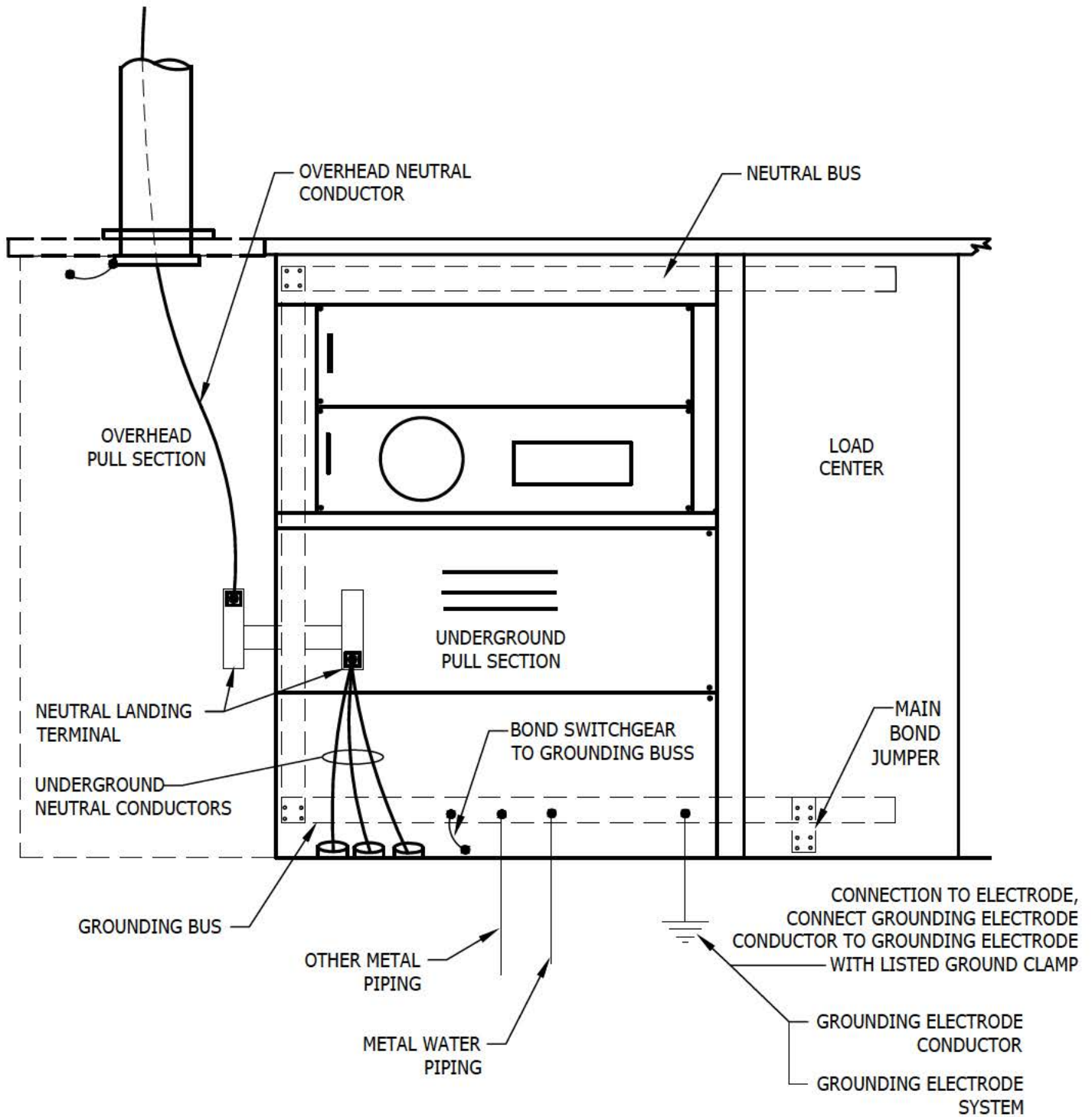

SEE NEC ARTICLE 250 FOR REFERENCE.

FORMALLY: SR-453 Page 13

700 SECTION CUSTOMER TECHNOLOGIES

<u>TITLE</u>	<u>SR-No.</u>
<u>Customer Installations:</u>	
Installation and Operation of Interconnected Distributed Generation Sources (Including Emergency and Standby Systems)	701
Electric Service Requirements For Small Interconnected Distributed Generation Sources	702
Electric Service Requirements For Medium-Sized Commercial Interconnected Distributed Generation Sources	703
▶ Metering Requirements for Distributed Generation Facilities Larger Than 1MW	705
Backup Generator Connection Requirements	709
Interconnection Requirements - Distributed Energy Storage Systems, Single-Phase	710



CUSTOMER INSTALLATION

CUSTOMER INSTALLATION AND OPERATION OF INTERCONNECTED DISTRIBUTED GENERATION SOURCES (INCLUDING EMERGENCY AND STANDBY SYSTEMS)

The customer shall not use any other electric power source, including distributed, emergency, and standby generation sources, in parallel with TEP/UES's service and power system, except as provided herein.

1. The construction and installation of interconnected distributed generation (DG), including standby and emergency generation facilities (hereinafter referred to as "Facilities") must comply with the National Electrical Code (NEC) and TEP/UES's Interconnection Requirements for Distributed Generation.
2. Synchronous, parallel operation of these Facilities with TEP/UES's power system may be permitted under the following conditions:
 - a. All customer Facilities, including switching devices and other special equipment, must adhere to all applicable UL and IEEE standards and recommended practices, and be approved by TEP/UES. It is recommended that the customer consult with the Company prior to commencement of design, construction, and installation of the Facilities.
 - b. The Facilities must conform to IEEE 519 on harmonic levels, flicker, and waveform distortion, and shall not produce excessive voltage or frequency variations of TEP/UES's power system. Customer is also required to maintain generator power factor and phase current imbalance (3-phase system) within TEP/UES prescribed limits. (Refer to TEP/UES's Interconnection Requirements for Distributed Generation)
 - c. TEP/UES must have access to the customer's DG disconnect switch clearly labeled in 1" high letters stating "Utility DG Disconnect". The switch shall be a gang-operated, load-break device capable of isolating all ungrounded conductors of the Facility from the utility system. The switch shall be accessible to TEP/UES operating personnel, and shall be lockable, and clearly indicate open or closed switch position with a visible air-gap employed in the open position. The switch shall be visually inspected to determine that the switch is open.
 - d. As required by NEC Article 705.10, a permanent sign shall be installed at the service entrance indicating the type(s) and location(s) of all electric power production sources capable of parallel operation with the TEP/UES system. Also in accordance with NEC Article 705.10, labeling shall be provided at all locations of all such electric power production sources. Installations with large numbers of power production sources shall be permitted to be designated by groups.
 - e. In accordance with standard utility safe operating practices, TEP/UES shall have the right to temporarily disconnect or disable the Facilities from TEP/UES's power system. Whenever reasonably possible, advance notice will be given to the customer prior to such actions.
 - f. The customer may be required by TEP/UES to modify the Facilities to accommodate special TEP/UES requirements, such as special metering, power factor correction capacitors, harmonic filters, telemetry, and protective devices.
 - g. TEP/UES may require the customer to have written operating instructions delineating procedures, mutually agreed upon between TEP/UES and the customer, that are to be followed in the execution of both routine and emergency operations.

FORMERLY SR-1.20, SECTION 100



		INITIATED BY	ED	REVISION NO.	0	SR-701 Pg. 1 of 2
		ESR COMM.	9-17	ESR COMM.	-	
				EFFECTIVE DATE	-	

CUSTOMER INSTALLATION

CUSTOMER INSTALLATION AND OPERATION OF INTERCONNECTED DISTRIBUTED GENERATION SOURCES (INCLUDING EMERGENCY AND STANDBY SYSTEMS)

- h. For customers operating Facilities in excess of their own power and energy needs and having primary voltage service, TEP/UES may require the customer to have full-time, qualified operations employees to operate the Facilities.
 - i. The customer must pay TEP/UES for any costs TEP/UES may incur as a result of the customer's Facilities.
 - j. The Customer agrees to defend, indemnify and hold harmless TEP/UES, its directors, officers, employees, and agents from any and all liability, loss, or damage (including, without limitation, damage to the TEP/UES's property) which TEP/UES, its directors, officers, employees, and agents may suffer as a result of any claim, demand, cost or judgment against it arising out of or in any way connected with the construction, installation and/or operation of the Facilities.
 - k. TEP/UES reserves the right to terminate the customer's interconnected use of these Facilities if they are not installed and operated within the guidelines established by TEP/UES.
 - l. An interconnection agreement between TEP/UES and the customer will be required for all Facilities that are to be operated in parallel with TEP/UES's power system.
 - m. The customer may need to meet additional requirements for this Facility. (Refer to TEP/UES's Interconnection Requirements for Distributed Generation).
 - n. The customer shall submit an interconnection application to TEP/UES prior to establishing parallel operation with TEP/UES's power system. The application and any required supplemental information shall be in accordance with TEP/UES's Interconnection Requirements for Distributed Generation. The application process allows TEP/UES to review the customer's proposed facilities for compliance with standards and to identify any necessary upgrades to TEP/UES facilities. The application is a necessary precursor to completing the interconnection agreement specified in Section 2.l. above.
 - o. TEP/UES may require the customer to arrange for inspection and testing of customer Facilities related to interconnection with the utility.
3. Customer-owned generating facilities intended solely for the purpose of supplying customer load during a TEP/UES power outage are not subject to the above requirements provided they conform to the following:
- a. The customer's equipment must transfer load between the TEP/UES system and the generator in an open-transition or non-parallel mode allowing no opportunity for backfeed of the TEP/UES system.
 - b. Any automatic transfer scheme must employ a double-throw, "break-before-make" transfer switch of fail-safe design such that under no circumstances will the generating facility electrically interconnect with the TEP/UES system.
 - c. Customer shall furnish documentation verifying that the transfer scheme meets non-parallel requirements.
 - d. TEP/UES reserves the right to inspect any customer equipment that functions as part of the transfer operation prior to granting approval to place in service.

FORMERLY SR-1.21, SECTION 100

		INITIATED BY	ED	REVISION NO.	0	SR-701 Pg. 2 of 2
		ESR COMM.	9-17	ESR COMM.	-	
				EFFECTIVE DATE	-	

INTERCONNECTION REQUIREMENTS INVERTER-BASED DISTRIBUTED GENERATION SOURCES FOR SINGLE-PHASE CUSTOMER SERVICES

1. Purpose

These electric service requirements include information for use by the Service Provider and customers for interconnection and parallel operation of small inverter-based, distributed generation (DG) sources with the Service Provider's distribution system. The document is an application of SR-701 "GENERAL REQUIREMENTS FOR CUSTOMER INSTALLATION AND OPERATION OF DISTRIBUTED GENERATION SOURCES" along with the "DISTRIBUTED GENERATION INTERCONNECTION REQUIREMENTS (DGIR)" as filed with and approved by the Arizona Corporation Commission (ACC). The requirements presented are to ensure the safety of both utility and customer personnel and property.

2. Applicability

This document applies to all distributed generation sources, single-phase, inverter-based, capable of parallel operation with the Service Provider's distribution system. It pertains only to interconnection with single-phase, 120/240V, 3-wire services. For interconnection with three-phase services, please refer to SR-703.

3. Definitions

Backfeed: To energize a section of the Service Provider's distribution system from a generation source other than the Service Provider.

Disconnect Switch: A visible open disconnect device that the customer is required to install and maintain in accordance with the requirements herein. It will completely isolate the customer's generating facility from the Service Provider grid.

Distributed Generation (DG): Any type of customer electrical generator, static inverter, or generating facility interconnected with the distribution system that either (1) has the capability of being operated in electrical parallel with the distribution system or (2) can feed a customer load that can also be fed by the distribution system.

Distributed Generation Interconnection Requirements (DGIR): Document conformed to ACC Docket No. E-00000A-99-0431 Decision No. 69674, dated June 28, 2007, that describes, procedural, administrative, and technical requirements for the interconnection of DG to the Service Provider's distribution system for the purpose of parallel operation. The DGIR document can be found at the following link:
<https://www.tep.com/wp-content/uploads/2016/04/dgir.pdf>



Distribution System: The infrastructure constructed, maintained, and operated by the Service Provider to deliver electric service to retail customers at primary and secondary distribution voltages (13.8kV and less).

Generating Facility: All or part of the customer's electrical generator(s) and/or inverter(s) together with all protective, safety, and associated equipment necessary to produce electric power at the customer's facility.

Island: A condition in which a portion of the Service Provider's distribution system is energized solely by one or more customer generating facilities through the associated point(s) of interconnection while that portion of the Service Provider distribution system is electrically separated from the rest of the Service Provider distribution system.

Line Side (Supply Side) Interconnection: Interconnection of the customer generation output between the Service Provider revenue meter and the customer main service disconnect(s).

Load Side Interconnection: Interconnection of the customer generation output at a point on the customer-side of a main service disconnect.

		INITIATED BY	DM	REVISION NO.	1	SR-702 
		ESR COMM.	9-17	ESR COMM.	3-18	
				EFFECTIVE DATE	3-18	

INTERCONNECTION REQUIREMENTS INVERTER-BASED DISTRIBUTED GENERATION SOURCES FOR SINGLE-PHASE CUSTOMER SERVICES

3. Definitions (cont'd)

Parallel System: A generating facility that is electrically interconnected to a bus common with the Service Provider distribution system, either on a momentary or continuous basis.

Point of Interconnection: The physical location where the DG conductors are connected to the customer's service.

Service Provider: A regulated electric utility that furnishes electric power and associated metering services to retail electrical customers in its defined service area. For purposes of this document, Service Provider will connote either Tucson Electric Power Company or Unisource Energy Services.

Static Inverter: A power electronic device that converts DC power to AC by means of electronic switching. For purposes of this document, only those static inverters designed to automatically separate from the Service Provider system upon loss of utility voltage and prior to reclosing of the Service Provider feeder breaker shall be acceptable for interconnection of DG systems.

- (a) String Inverter: A single static inverter designed to receive the DC output of a string of series connected solar photovoltaic panels.
- (b) Micro-inverter: An inverter integral with an individual solar photovoltaic panel that performs DC to AC voltage conversion so that panel output power is an AC waveform. Individual micro-inverter panel outputs are typically routed to a combiner panel for collective output on to the point of interconnection.

4. Standards



All customer equipment shall conform to the nationally-recognized standards and recommended practices. These include, but are not limited to, the following:

- (a) NFPA 70 - National Electrical Code (NEC)
- (b) IEEE 1547 - Standard for Interconnecting Distributed Resources with Electric Power Systems
- (c) IEEE 1547.1 - Standard for Conformance Test Procedures for Equipment Interconnecting Distributed Resources with Electric Power Systems
- (d) IEEE 519 - Recommended Practices and Requirements for Harmonic Control in Electrical Power Systems
- (e) ANSI C84.1- Electric Power Systems and Equipment-Voltage Ratings (60Hz)
- (f) UL 1741- Inverters, Converters, Controllers and Interconnection System Equipment for Use with Distributed Energy Resources

5. Service Provider Design Review and Approval

Prior to installation of customer interconnection facilities, customer shall submit a DG interconnection application to the Service Provider for review and written approval. Application forms may be found on the Service Provider's website. Documentation to be furnished with the application may include an electrical one-line diagram, an electrical three-line diagram, site plan, and equipment elevation drawings. Following approval, customer shall not remove, alter, modify, or change the equipment specifications, including, without limitation, the plans, control and protective devices or settings, and the generating facility system design, type, size, or configuration. If the customer desires to make such changes or modifications, they must revise and resubmit plans describing the changes or modifications for approval. No such change or modification may be made without prior approval.



		INITIATED BY	DM	REVISION NO.	3	SR-702 Pg. 2 of 12
		ESR COMM.	9-17	ESR COMM.	8-18	
				EFFECTIVE DATE	8-18	

INTERCONNECTION REQUIREMENTS INVERTER-BASED DISTRIBUTED GENERATION SOURCES FOR SINGLE-PHASE CUSTOMER SERVICES

6. Metering Requirements

(a) General:

The customer shall provide and install a meter socket, in accordance with Service Provider requirements, to meter the generator output. This is referred to as the production or DG meter socket. Equipment should be selected from the approved material list in SR-452. (At present, for residential single-phase DG systems only, Service Provider will furnish a DG meter socket to the customer if they so request.) Service Provider will furnish and install the DG meter.

Under no circumstances shall any metering enclosure be used as a conduit or raceway for any conductors other than those phase conductors being metered and the associated grounded conductor (neutral) and grounding conductor (equipment ground). A neutral must be run from the customer service to the DG meter socket and terminated on the neutral bus for DG systems that may not require a neutral to operate.

No loads, technologies, or strategies not related to the customer's generating facility may divert, for any purpose, DG energy that would otherwise have been metered as DG production.

(b) Arrangement and Location:



The DG meter shall be located within 10 feet of the revenue meter, within line of sight and not separated by walls, gates or obstructions. Variances are not granted based on convenience or preference and must be submitted in the DG application and subsequently approved prior to construction. Meter sockets shall be accessible to Service Provider personnel at all times.

(c) Meter Socket Identification:

The DG meter socket shall be labeled "Distributed Generation Meter" and shall employ signage as shown in pages 6, 8, 10, and 12 of this SR. Service Provider will furnish the required warning placard to the customer through their distributor, Border States Electric.

(d) Meter Socket Heights:

Minimum and maximum meter socket heights shall be as specified in SR-405 page 2.

(e) Equipment Protection and Grounding:

Meter sockets and all related metering enclosures and equipment shall be grounded in accordance with the NEC, any applicable local codes. In addition, Service Provider requires bonding at all box connectors as shown in wiring schematics on page 7, 9 & 11.

(f) Working Space:

Working space requirements for all metering equipment shall be as specified in SR-405 page 10.

7. Disconnect Switches

(a) General:



As required by the DGIR, the customer shall provide and install a DG disconnect switch to isolate all ungrounded conductors of the generating facility from the Service Provider system. The switch shall be a gang-operated load-break device with a visible air-gap in the open position. It shall be rated for the current and voltage requirements of the generating facility and shall be lockable in the open position.

For residential single-phase DG systems requesting load side interconnection only, the Service Provider will furnish a DG disconnect switch to the customer, if they so request.

Under no circumstances shall any DG disconnect switch enclosure be used as a conduit or raceway for any conductors other than the metered phase conductors, associated grounded conductor (neutral) and associated grounding conductor (equipment ground) of the DG output circuit. All phase conductors shall be terminated on appropriate terminals inside the switch enclosure.

(b) Arrangement and Location:

The DG disconnect switch and all required meter switches shall be located within 10 feet of the customer's revenue meter and installed between the revenue meter and the DG meter. Variances are not granted based on convenience or preference and must be requested in the DG application and subsequently approved prior to construction. Switch installations shall be accessible and operable to Service Provider personnel at all times.

 	INITIATED BY	DM	REVISION NO.	4	SR-702 Pg. 3 of 12
	ESR COMM.	9-17	ESR COMM.	3-24	
			EFFECTIVE DATE	3-24	

INTERCONNECTION REQUIREMENTS INVERTER-BASED DISTRIBUTED GENERATION SOURCES FOR SINGLE-PHASE CUSTOMER SERVICES

7. Disconnect Switches (cont'd)

(c) Labeling:

The DG disconnect switch shall be labeled "Utility DG Disconnect" and shall employ signage as shown in pages 6, 8, 10, and 12 of this SR. Service Provider will furnish the required warning label to the customer through their distributor, Border States Electric.



(d) Disconnect Switch Heights:

Minimum and maximum disconnect heights shall match the requirements for meter socket heights as specified in SR-405 page 2.

(e) Equipment Protection and Grounding:

DG disconnect switch enclosures shall be grounded in accordance with the NEC, any applicable local codes. In addition, Service Provider requires bonding at all box connectors as shown in wiring schematics on page 7, 9 & 11.



8. Technical Requirements

(a) Line Side Interconnections

For line side interconnections, as are permitted by NEC, the following requirements apply:





- (1) A line side interconnection constitutes a new service and is subject to all applicable NEC requirements and/or requirements adopted by the local code-enforcement authority.
- (2) Customer is required to arrange a power-kill with Service Provider to de-energize customer equipment before performing line side interconnection work. The Service Provider will energize this service only after the facility has passed inspection by both the Service Provider Design Department and the applicable government agency. Notification from the government agency must be received by the Service Provider as described in the process for new services elsewhere in these Service Requirements.
- (3) Any line side interconnection shall be made without modifications to any factory installed and/or factory listed equipment or components. Please contact Service Provider Design Department for additional guidance regarding this matter.
- (4) For 200A Milbank meter sockets only, customer may install Milbank tap connectors, catalog number KA77-INT, to complete the line side interconnection inside the revenue meter base enclosure. See pages 10 and 11 for this SR for further information.

(b) Minimum Protective Requirements

- (1) Inverter shall be set to detect and trip for any abnormal operating condition on the Service Provider's system.
- (2) Circuit breakers, if backfed, shall be suitable for such operation.
- (3) Static inverters shall be tested to UL 1741 by a Nationally Recognized Testing Laboratory (NRTL) certified by OSHA to perform the UL 1741 test standard.

(c) Distribution Transformer

- (1) Customer's single-phase generator can only be connected to the Service Provider's single-phase distribution transformers.
- (2) Customer generators with a combined total rating of over 10 kWAC, as measured at the service entrance, will be required to be isolated from other customers served from the same Service provider transformer. This will be accomplished by installing a separate dedicated transformer to serve only the customer with DG in excess of 10 kWAC. All work necessary to modify existing Service Provider facilities to accommodate customer-owned DG shall be done at the customer's expense.

 	INITIATED BY	DM	REVISION NO.	2	SR-702 Pg. 4 of 12
	ESR COMM.	9-17	ESR COMM.	8-18	
			EFFECTIVE DATE	8-18	

INTERCONNECTION REQUIREMENTS INVERTER-BASED DISTRIBUTED GENERATION SOURCES FOR SINGLE-PHASE CUSTOMER SERVICES

9. Customer Operating Requirements

- (a) Quality of Service:
The operation of the customer's generation facility must not reduce the quality of service of the distribution system to the other Service Provider customers. No abnormal voltages, currents, frequencies, or interruptions are permitted.
- (b) De-energized Service Provider Circuit:
The customer will at no time energize a de-energized Service Provider's circuit.
- (c) Inhibited Parallel Operation
 - (1) If the Service Provider circuit is de-energized, the inverter shall not attempt to reconnect their system until power has been restored. The inverter shall delay reconnection for parallel operation of its generating facilities for a minimum of five minutes after the Service Provider voltage and frequency are restored to normal. Service Provider is not responsible for damage caused to the customer's facility as a result of automatic or manual reclosing of distribution feeder breakers or reclosers.
 - (2) The customer is not prohibited from isolating their system from the Service Provider and supplying their own premise wiring while the Service Provider's circuit is de-energized.
- (d) Customer Responsibility for Damage Caused by Customer Generating Facilities:
The customer is responsible for damage caused to other customers and to the Service Provider as a result of improper operation or malfunction of their generation facilities.
- (e) Service Provider:
Service Provider is not responsible for damage caused to other customers and to Service Provider's facilities as a result of improper operation or malfunction of the customer's generating facilities.
- (f) Inverter that Provides backup Power:
Any inverter providing a backup power supply for utility outages must separate from the Service Provider as required by UL 1741. Inverters approved for this function include: SMA TL-22 series.

LOAD SIDE INTERCONNECTION LAYOUT SINGLE-PHASE SERVICE 400A AND LESS

DRAWING 1A

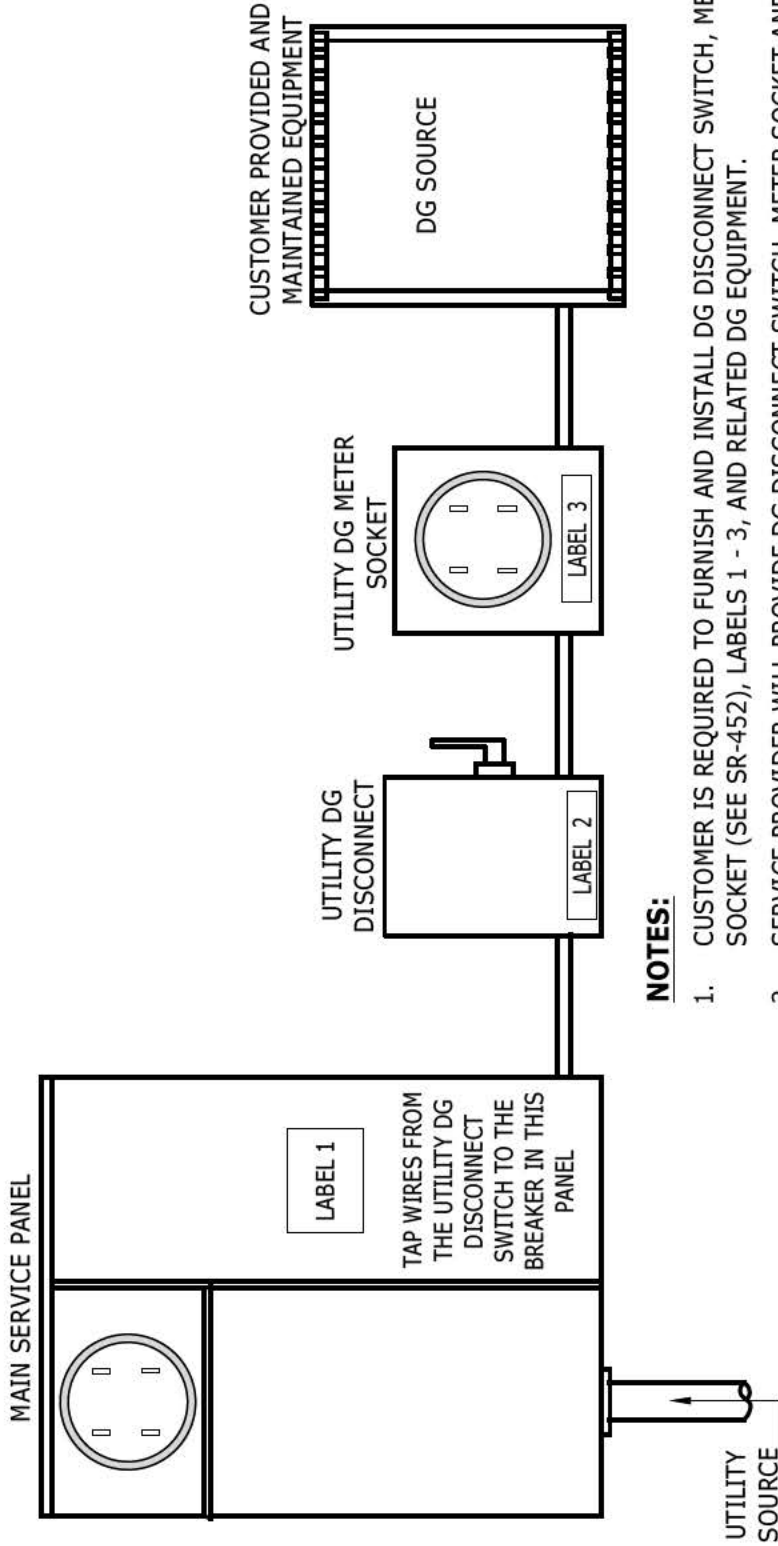

NOTES:

1. CUSTOMER IS REQUIRED TO FURNISH AND INSTALL DG DISCONNECT SWITCH, METER SOCKET (SEE SR-452), LABELS 1 - 3, AND RELATED DG EQUIPMENT.
2. SERVICE PROVIDER WILL PROVIDE DG DISCONNECT SWITCH, METER SOCKET AND LABELS ONLY FOR APPROVED SINGLE-PHASE RESIDENTIAL APPLICANTS.
3. DG METER PROVIDED AND INSTALLED BY SERVICE PROVIDER.
4. A GOVERNMENTAL AGENCY CLEARANCE IS REQUIRED FOR ALL DG INSTALLATIONS.
5. LABELS ARE AVAILABLE FOR PURCHASE AT BORDER STATES ELECTRIC 294-1414.



LABEL 1
2-15-1912



LABEL 2
2-15-1913



LABEL 3
2-15-1911

**LOAD SIDE INTERCONNECTION WIRING
SINGLE-PHASE SERVICE
400A AND LESS**

DRAWING 1B

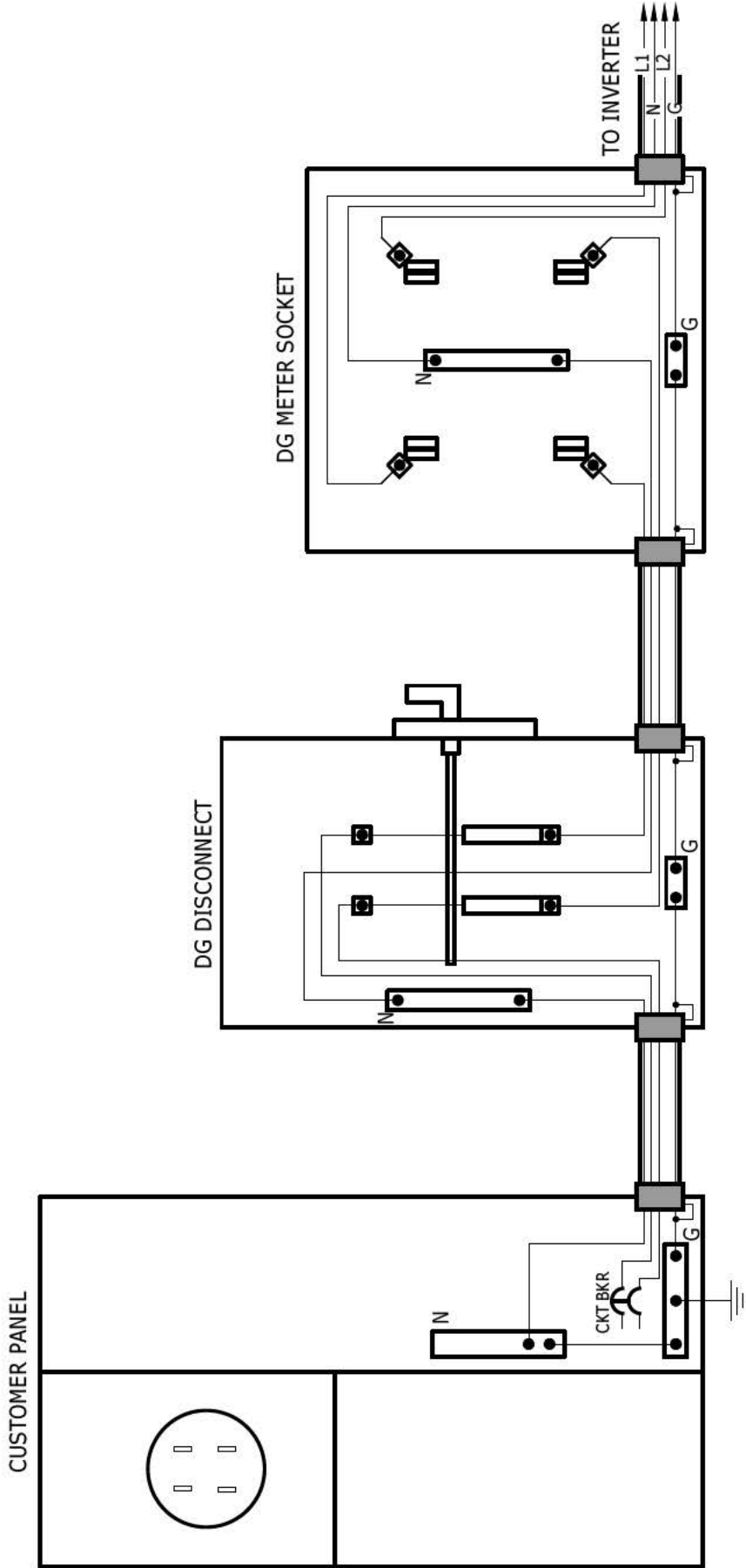

NOTE:

1. A NEUTRAL MUST BE RUN FROM CUSTOMER PANEL TO DG METER SOCKET AND TERMINATED ON THE NEUTRAL BUS FOR DG SYSTEMS THAT MAY NOT REQUIRE A NEUTRAL TO OPERATE.

FORMERLY SR-704, page 1

LINE SIDE TAP INTERCONNECTION LAYOUT SINGLE-PHASE SERVICE 400A AND LESS

DRAWING 2A

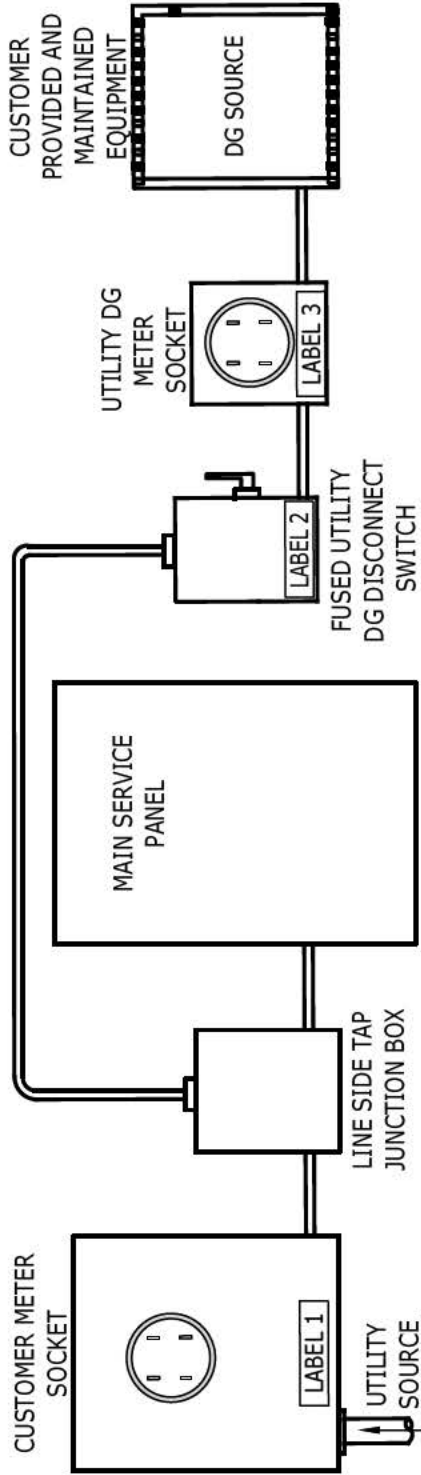

NOTES:

1. CUSTOMER IS REQUIRED TO FURNISH AND INSTALL DG DISCONNECT SWITCH, METER SOCKET (SEE SR-452), LABELS 1 - 3, AND RELATED DG EQUIPMENT.
2. SERVICE PROVIDER WILL PROVIDE METER SOCKET AND LABELS ONLY FOR APPROVED SINGLE-PHASE RESIDENTIAL APPLICANTS.
3. DG METER PROVIDED AND INSTALLED BY SERVICE PROVIDER.
4. A SERVICE PROVIDER DESIGN DEPARTMENT INSPECTION IS REQUIRED FOR APPROVAL.
5. A GOVERNMENTAL AGENCY CLEARANCE IS REQUIRED FOR ALL DG INSTALLATIONS.
6. LABELS ARE AVAILABLE FOR PURCHASE AT BORDER STATES ELECTRIC 294-1414.
7. LINE SIDE TAPS ARE NOT ALLOWED INSIDE THE CUSTOMER SERVICE PANEL. TAPS SHALL BE MADE INSIDE AN APPROVED JUNCTION BOX USING TAP (LUG) TYPE CONNECTORS.
8. JUNCTION BOX SHALL BE HOFFMAN CATALOG # A12R126 OR EQUAL. LARGER DIMENSION BOXES ARE ACCEPTABLE IF THEY MEET THE SAME REQUIREMENTS AS THE A12R126.
9. SINGLE PHASE CUSTOMER METER SOCKET MUST BE WIRED PER SR-408. IF LOCATION OF JUNCTION BOX NECESSITATES A VARIANCE TO SR-408, CUSTOMER MUST USE A MILBANK CATALOG # U4518-XL-W SOCKET OR EQUAL TO ALLOW FOR ADEQUATE SPACE FOR WIRING ROUTING.
10. CUSTOMER MAY RE-USE AN EXISTING ALL-IN-ONE PANEL AS A LOAD CENTER ONLY.

WARNING
ELECTRICAL SHOCK HAZARD
DISTRIBUTED GENERATION PRESENT
TERMINALS ON LINE AND LOAD SIDE MAY BE ENERGIZED

WARNING
UTILITY DG DISCONNECT PANEL MAY BE ENERGIZED BY UTILITY OR CUSTOMER GENERATION

WARNING
DISTRIBUTED GENERATION METER PANEL MAY BE ENERGIZED BY UTILITY OR CUSTOMER GENERATION

LABEL 1
2-15-1912

LABEL 2
2-15-1913

LABEL 3
2-15-1911

FORMERLY SR-702, page 7

LINE SIDE TAP INTERCONNECTION WIRING
SINGLE-PHASE SERVICE
400A AND LESS

DRAWING 2B

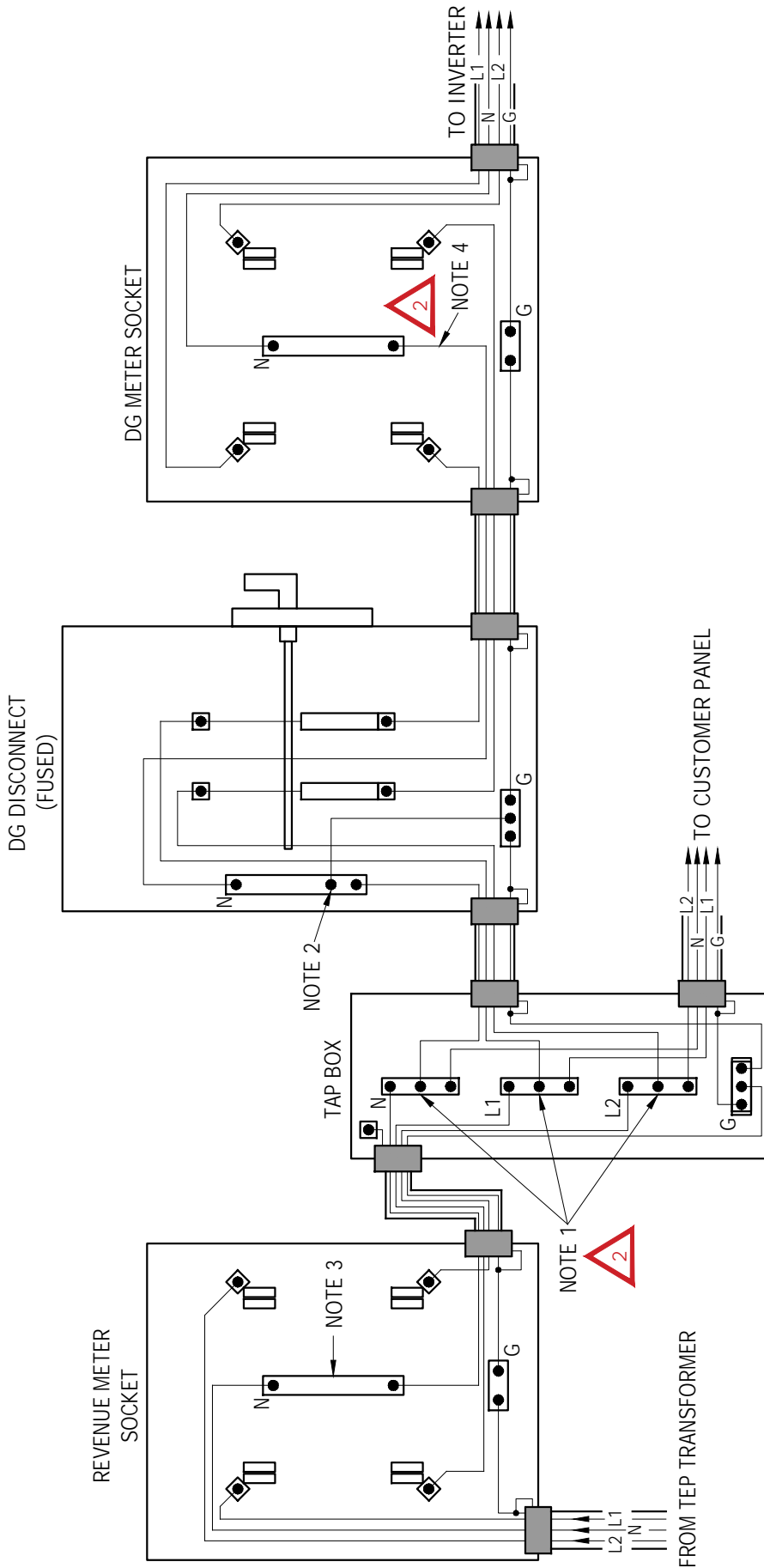

NOTES:

1. LINE SIDE TAP MUST BE MADE USING LUG-TYPE CONNECTORS.
2. FUSED DISCONNECT NEUTRAL MUST BE BONDED TO GROUND VIA BONDING JUMPER OR BONDING SCREW FOR LINE SIDE TAP.
3. NEUTRAL CONNECTOR MUST BE BONDED TO SOCKET ENCLOSURE.
4. A NEUTRAL MUST BE RUN FROM TAP BOX TO DG METER SOCKET AND TERMINATED ON THE NEUTRAL BUS FOR DG SYSTEMS THAT MAY NOT REQUIRE A NEUTRAL TO OPERATE.

FORMERLY SR-704, page 2

DRAWING 3A 

LINE SIDE INTERCONNECTION LAYOUT
 METER SOCKET TAP CONNECTOR
 SINGLE-PHASE SERVICE, 200A

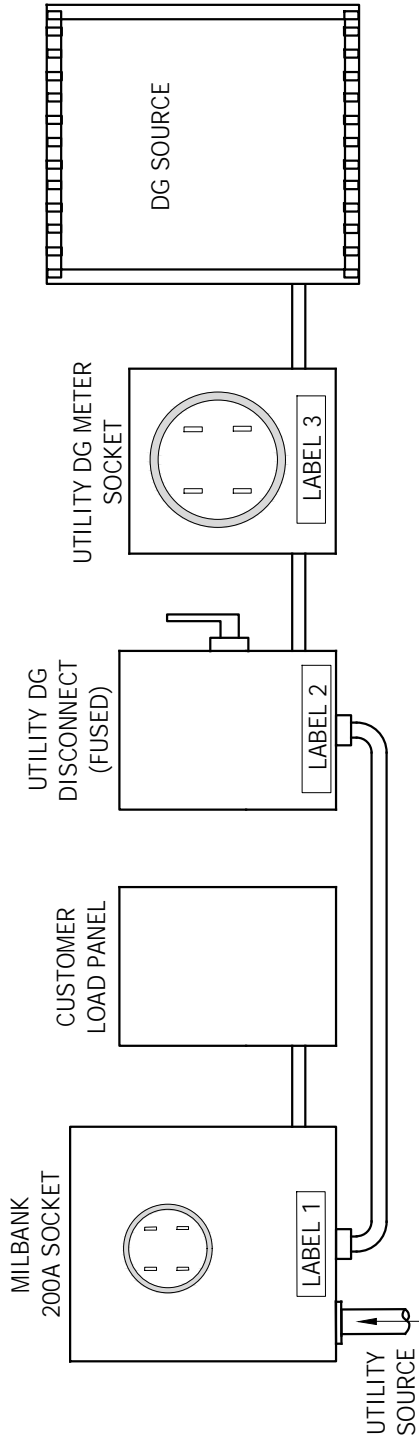

NOTES:

1. CUSTOMER IS REQUIRED TO FURNISH AND INSTALL THE DG DISCONNECT SWITCH, DG METER SOCKET (SEE SR-452), LABELS 1 - 3 AND RELATED DG EQUIPMENT.
2. DG METER PROVIDED AND INSTALLED BY SERVICE PROVIDER.
3. A GOVERNMENTAL AGENCY CLEARANCE IS REQUIRED FOR ALL DG INSTALLATIONS.
4. LABELS ARE AVAILABLE FOR PURCHASE AT BORDER STATES ELECTRIC 294-1414.



LABEL 1
2-15-1912



LABEL 2
2-15-1913



LABEL 3
2-15-1911

**CUSTOMER OWNED DG
LINE SIDE TAP INTERCONNECTION WIRING
(DUAL LUG TAP CONNECTORS)**

DRAWING 3B 

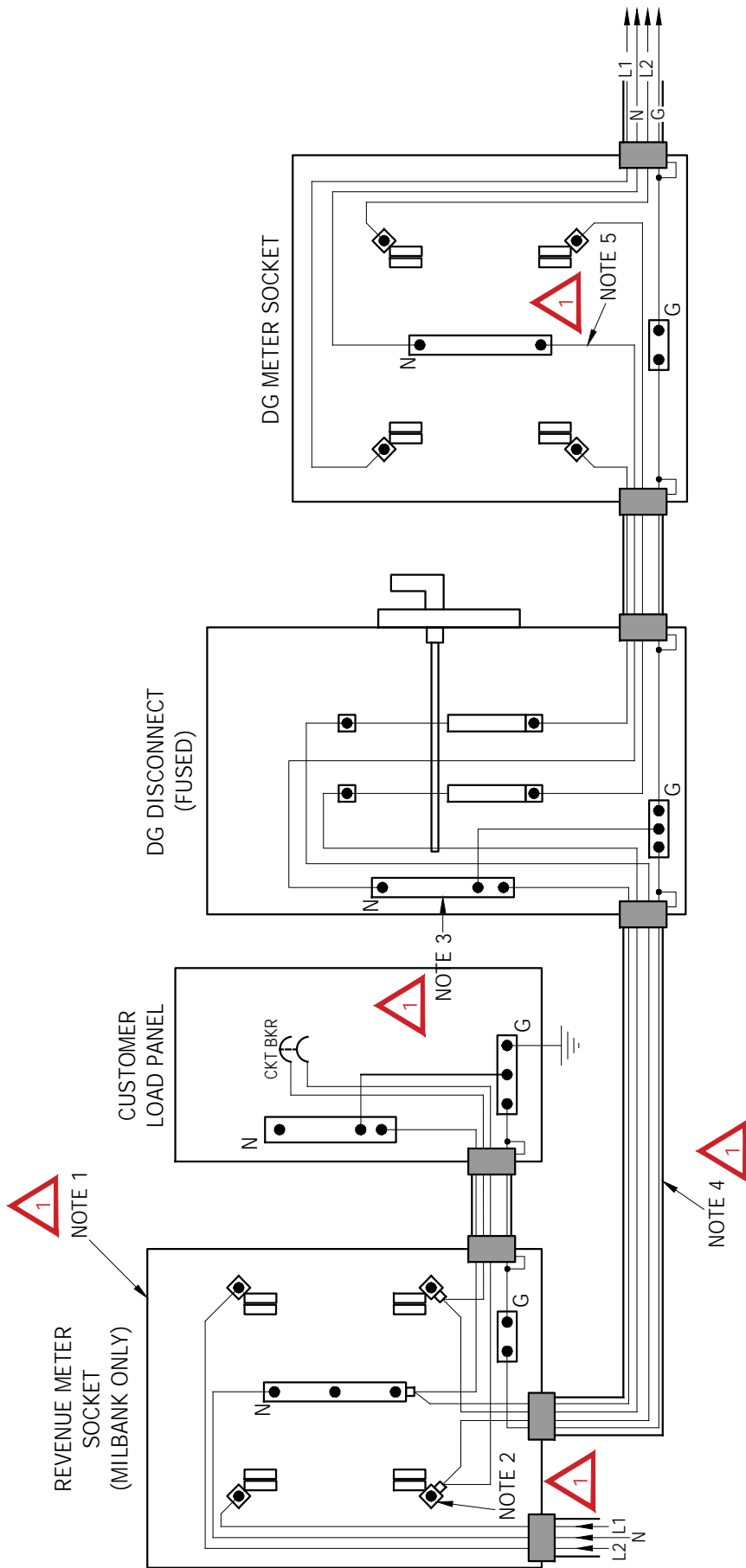

NOTES:

1. METER SOCKET MUST BE MILBANK, CATALOG No. U4518-XL-W.
2. TAP CONNECTORS MUST BE MILBANK, CATALOG No. K4977-INT.
3. FUSED DISCONNECT NEUTRAL MUST BE BONDED TO GROUND VIA BONDING JUMPER OR BONDING SCREW FOR LINE SIDE TAP.
4. LABEL CONDUIT WITH "DG TAP CONDUCTORS".
5. A NEUTRAL MUST BE RUN FROM REVENUE METER SOCKET TO DG METER SOCKET AND TERMINATED ON THE NEUTRAL BUS FOR DG SYSTEMS THAT MAY NOT REQUIRE A NEUTRAL TO OPERATE.



SERVICE CONNECTION DETAIL
MULTI-METER INSTALLATIONS

DRAWING 4 

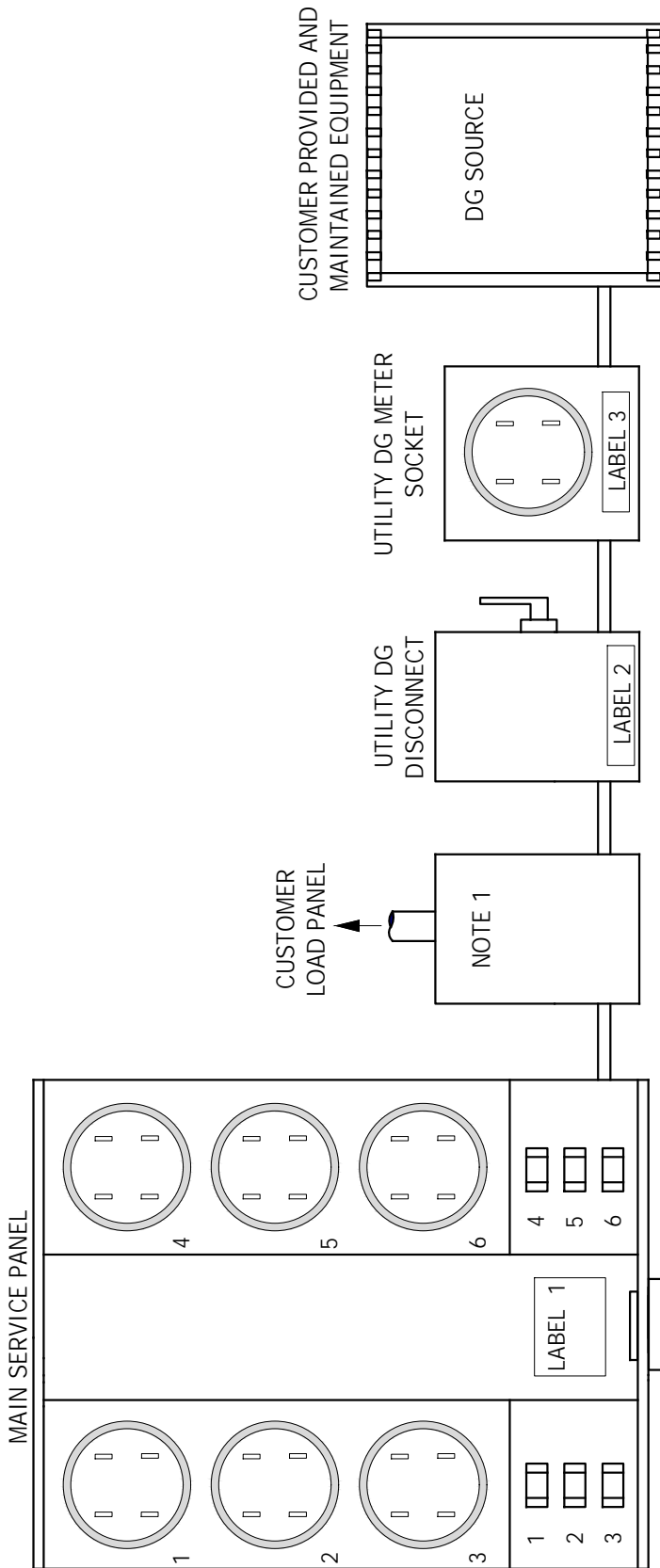

NOTES:

1. DG CIRCUIT MUST BE TAPPED FROM AN INDIVIDUAL CUSTOMER CIRCUIT VIA A SEPARATE JUNCTION BOX. NO LINE SIDE TAPS ARE PERMITTED.
2. CUSTOMER IS REQUIRED TO FURNISH AND INSTALL THE DG DISCONNECT SWITCH, DG METER SOCKET (SEE SR-452), LABELS 1 - 3 AND RELATED DG EQUIPMENT.
3. DG METER PROVIDED AND INSTALLED BY SERVICE PROVIDER.
4. A GOVERNMENTAL AGENCY CLEARANCE IS REQUIRED FOR ALL DG INSTALLATIONS.
5. LABELS ARE AVAILABLE FOR PURCHASE AT BORDER STATES ELECTRIC 294-1414.



LABEL 1
2-15-1912



LABEL 2
2-15-1913



LABEL 3
2-15-1911

ELECTRIC SERVICE REQUIREMENTS FOR MEDIUM-SIZED COMMERCIAL INTERCONNECTED DISTRIBUTED GENERATION SOURCES

1. Purpose

These electric service requirements include information and criteria for use by TEP/UES employees and customers in regard to the interconnection and parallel operation of small distributed generation sources with TEP/UES's distribution system. The document is intended as an application of the TEP/UES policy "Customer Installation and Operation of Interconnected Distributed Generation Sources" set forth in SR-701. The requirements presented herein are to ensure the safety of both TEP and customer personnel and property.

2. Applicability

This document applies to all three-phase distributed generation sources, above 50 kWac to 300 kWac nameplate rating, capable of parallel operation with TEP/UES's system. Any generation source larger than 300 kWac requires review and approval by TEP Engineering and may entail additional requirements beyond those detailed in this document.

3. Definitions

Backfeed: To energize a section of the TEP/UES distribution system from a generation source other than TEP/UES.

Disconnect Switch: A visible open disconnect device that the customer is required to install and maintain in accordance with the requirements set forth herein. It will completely isolate the customer's generating facility from the TEP/UES grid.

Distributed Generation (DG): Any type of customer electrical generator, static inverter, or generating facility that has the capability of being operated in electrical parallel with the TEP/UES distribution system.

Distribution System: The infrastructure constructed, maintained, and operated by TEP/UES to deliver electric service to retail customers at primary and secondary distribution voltages (13.8kV and less).

Generating Facility: All or part of the customer's electrical generator(s) or inverter(s) together with all protective, safety, and associated equipment necessary to produce electric power at the customer's facility.



Island: A condition in which a portion of the TEP/UES electric power system is energized solely by one or more customer generating facilities through the associated point(s) of interconnection while that portion of the TEP/UES electric power system is electrically separated from the rest of the TEP/UES electric power system.

Parallel System: A generating facility that is electrically interconnected to a bus common with the TEP electric distribution system, either on a momentary or continuous basis.

Point of Interconnection (Delivery): The physical location where TEP/UES service conductors are connected to the customer's service conductors to allow parallel operation of the customer's generating facility with the TEP/UES electric distribution system.

Static Inverter: A power electronic device that converts DC power to AC by means of electronic switching. For purposes of this document, only those static inverters designed to automatically separate from the TEP/UES system upon loss of utility voltage and prior to reclosing of the TEP/UES feeder breaker shall be acceptable for interconnection of DG systems.

FORMERLY SR-1.23, SECTION 100

		INITIATED BY	DM	REVISION NO.	0	SR-703 Pg. 1 of 6
		ESR COMM.	9-17	ESR COMM.	-	
				EFFECTIVE DATE	-	

ELECTRIC SERVICE REQUIREMENTS FOR MEDIUM-SIZED COMMERCIAL INTERCONNECTED DISTRIBUTED GENERATION SOURCES

4. Standards

All customer equipment shall conform to the nationally-recognized standards and recommended practices. These include, but are not limited to the following:

- (a) NFPA 70--National Electrical Code (NEC)
- (b) IEEE 1547--Standard for Interconnecting Distributed Resources with Electric Power Systems
- (c) IEEE 1547.1--Standard for Conformance Test Procedures for Equipment Interconnecting Distributed Resources with Electric Power Systems
- (d) IEEE 929--Recommended Practice for Utility Interface of Photovoltaic Systems
- (e) IEEE 519--Recommended Practices and Requirements for Harmonic Control in Electrical Power Systems
- (f) ANSI C84.1--Electric Power Systems and Equipment--Voltage Ratings (60Hz)
- (g) UL 1741--Inverters, Converters, Controllers and Interconnection System Equipment for Use with Distributed Energy Resources

5. TEP/UES Design review and Approval

Prior to installation of customer interconnection facilities, customer shall submit a distributed generation interconnection application for TEP/UES's review and written approval. Appropriate application forms may be found at www.tep.com. Required documentation to be furnished with the application may include an electrical one-line diagram, an electrical three-line diagram, AC and DC control schematics, plant location diagram, and site plan. Following TEP/UES approval, customer shall not remove, alter or otherwise modify or change the equipment specifications, including, without limitation, the plans, control and protective devices or settings, and the generating facility system design, type, size or configuration. If the customer desires to make such changes or modifications, the customer must revise and resubmit to TEP/UES plans describing the changes or modifications for approval by TEP/UES. No such change or modification may be made without prior approval of TEP/UES.

6. Metering Requirements



(a) General:

The customer shall provide and install all necessary metering sockets and cabinets in accordance with TEP/UES service requirements, in locations acceptable to TEP/UES. TEP/UES will furnish and install the revenue meter (or revenue net meter) at the point of delivery to the customer's facility. TEP/UES also requires a generator output (or production) meter and will furnish and install such meter. Required equipment should be selected from the approved material list in SR-452.

Under no circumstances shall any metering enclosure be used as a conduit or raceway for any conductors other than those phase conductors being metered and the associated grounded conductor (neutral) and grounding conductor (equipment ground). Also, the customer shall not make any connection or termination on the utility side of the metering enclosure.

No loads, technologies, or strategies may divert, for any purpose, DG energy that would have otherwise been metered as DG production.

FORMERLY SR-1.23, SECTION 100

		INITIATED BY	DM	REVISION NO.	0	SR-703 Pg. 2 of 6
		ESR COMM.	9-17	ESR COMM.	-	
				EFFECTIVE DATE	-	

ELECTRIC SERVICE REQUIREMENTS FOR MEDIUM-SIZED COMMERCIAL INTERCONNECTED DISTRIBUTED GENERATION SOURCES

6. Metering Requirements (cont'd)

- (b) Arrangement and Location:
The revenue meter shall be located at the point of delivery to the customer's facility which is typically at or near the service entrance section. Meter location shall also comply with the requirements of SR-405 pages 3 through 5 of 10. The generator output meter shall be located within 10 feet of the revenue meter. Exceptions to this may be granted following engineering review and provided that appropriate labeling criteria are met. Refer to Drawings 1 for further details.
- (c) Meter Socket Identification:
Revenue meter socket identification shall be as required by SR-405 page 2 of 10. The generation meter socket shall be labeled "Distributed Generation Meter" and shall employ signage as shown in Drawings 1.
- (d) Meter Socket Heights:
Minimum and maximum meter socket heights shall be as specified in SR-405 page 2 of 10.
- (e) Equipment Protection and Grounding:
Customer shall provide and install protective cabinets or other approved enclosures for all meters and metering equipment in accordance with SR-405 page 5 of 10 when required by TEP/UES. Meter sockets and all related metering enclosures and equipment shall be grounded in compliance with the NEC and/or any applicable local codes.
- (f) Working Space:
Working space requirements for all metering equipment shall be as specified in SR-405 page 10 of 10.



7. Disconnect Switches

- (a) General:
As required by TEP/UES's Interconnection Requirements for Distributed Generation, the customer shall provide and install a disconnect switch to isolate all ungrounded conductors of the generating facility from the TEP/UES system. The switch shall be a gang-operated, load-break device with a visible air-gap in the open position. It shall be rated for the current and voltage requirements of the generating facility and shall be lockable in the open position. In addition to the DG Service disconnect switch, the customer shall also provide and install any required meter switches. For synchronous generators, an additional disconnect switch shall be installed between the DG meter and the generation source. Refer to SR-405 page 1 of 10 and Drawing 1 for further information.

Under no circumstances shall any DG disconnect switch enclosure be used as a conduit or raceway for conductors other than the phase, associated grounded conductor (neutral), and associated grounding conductor (equipment ground) of the DG output circuit. All Phase conductors shall be terminated on appropriate terminals inside the switch enclosure.

- (b) Location:
The DG Service disconnect switch and all required meter switches shall be located within 10 feet of the customer's service entrance section. Exceptions to this policy may be granted based on engineering review. Switch installations shall be accessible and operable to TEP/UES personnel at all times.
- (c) The DG Service disconnect switch shall be labeled as per the requirements of SR-1.20 and shall employ signage as shown in Drawing 1.

FORMERLY SR-1.23, SECTION 100

		INITIATED BY	DM	REVISION NO.	0	SR-703 Pg. 3 of 6
		ESR COMM.	9-17	ESR COMM.	-	
				EFFECTIVE DATE	-	

ELECTRIC SERVICE REQUIREMENTS FOR MEDIUM-SIZED COMMERCIAL INTERCONNECTED DISTRIBUTED GENERATION SOURCES

8. Technical Requirements

(a) Type of Service:

The type of distribution service available for medium-sized DG sources larger than 50 kWac up to 300 kWac is three-phase grounded wye. Available voltages are 208Y/120 4-wire and 480Y/277V 4-wire. Exceptions to this may be granted only after review and approval of TEP/UES Engineering.

(b) Line Side Taps:

In the case that a generator is connected or tapped to the line (TEP/UES) side of a service entrance main breaker, as may be permitted by the NEC, the following requirements apply:

1. A line side tap constitutes a new service as defined by the NEC and is subject to all applicable NEC requirements and/or requirements adopted by the local code-enforcement authority.
2. TEP/UES will energize this service only after the facility has passed the inspection of the applicable government agency and notification has been received by TEP/UES as is described in the process for new services elsewhere in these Service Requirements.
3. Any line side tap shall be made without modifications to any factory installed and/or factory listed equipment or components. Please contact the TEP/UES Design Department for additional guidance regarding this matter.



(c) Minimum Protective Requirements:

1. For generators capable of contributing fault current to the TEP/UES system, customer overcurrent protection shall be set to detect and trip for any fault between the customer's main breaker and TEP/UES's substation breaker prior to operation of the TEP/UES protective device. The customer's overcurrent device may trip either the customer's generator breaker or the customer's main breaker. Circuit breakers, if backfed, shall be suitable for such operation.
2. Overvoltage, undervoltage, overfrequency, and underfrequency protection shall be provided to separate the DG from the utility under adverse voltage and frequency conditions.
3. Synchronous generators require a synchronizing scheme in order to initiate and maintain parallel operation with the utility.
4. Phase and ground time and instantaneous overcurrent relays are required as part of the interconnection protection package. For DG installations not capable of supplying ground fault current for ground faults on the utility system, additional requirements may apply. See Section 8 (e) below for further information.
5. Overload tripping is required for any generator capable of sustained operation above its normal ampere rating.
6. Static inverters shall be tested to UL 1741 by a Nationally Recognized Testing Laboratory (NRTL) certified by OSHA to perform the UL 1741 test standard.

(d) Distribution Transformer

1. Customers' three-phase generators shall connect to the TEP/UES system through a TEP/UES wye - wye connected three-phase pad-mount transformers or wye - wye overhead three-phase transformer banks.
2. Customers with generators having a combined rating in the range of 50 kWac to 300 kWac will be required to be isolated from other customers fed off the same TEP/UES transformer. This can be accomplished by installing a separate transformer connecting to the TEP/UES distribution feeder that is dedicated to the customer with DG. All work necessary to modify existing TEP/UES facilities to accommodate customer-owned DG shall be done at the customer's expense.

FORMERLY SR-1.23, SECTION 100

		INITIATED BY	DM	REVISION NO.	0	SR-703 Pg. 4 of 6
		ESR COMM.	9-17	ESR COMM.	-	
			EFFECTIVE DATE		-	

ELECTRIC SERVICE REQUIREMENTS FOR MEDIUM-SIZED COMMERCIAL INTERCONNECTED DISTRIBUTED GENERATION SOURCES

8. Technical Requirements (cont'd)

(e) Effective Grounding of Distributed Generation:

Synchronous, induction, or inverter-based generation employing a three-wire output cannot supply current to a ground fault. Therefore, for any three-wire DG, the customer must furnish either a delta - grounded wye isolation transformer or a grounding transformer. The isolation transformer delta winding shall tie to the three-wire DG output. The grounded wye winding shall tie to the four-wire utility-sourced system. Exceptions may be granted for inverter-based generation if the inverter manufacturer can show that the inverter does not cause overvoltage during a utility ground fault. The inverter manufacturer will be required to present test data for verification. Test data shall include oscilloscope recordings of inverter output voltage during short circuit testing. Results of an open circuit test must also be provided demonstrating that the inverter does not over-modulate under such circumstances.

9. Customer Operations

This section provides the operating requirements that the customer must follow and the responsibilities that the customer must assume for the operating their generation in parallel to the TEP/UES system:

(a) Quality of service:

The operation of the customer's generation facility must not reduce the quality of service to the TEP/UES electric system or other TEP/UES customers. No abnormal voltages, currents, frequencies, or interruptions are permitted.

(b) De-energized TEP/UES circuit:

The customer will at no time energize a de-energized TEP/UES circuit.

(c) Inhibited parallel operation:

If while operating parallel to TEP/UES's system, any of the protective devices operate inhibiting parallel operation, the customer will perform the following procedures prior to attempting any further parallel operation with TEP/UES (Note: Static inverter based systems conforming to the technical requirements detailed above will automatically disconnect from the TEP system upon loss of utility voltage. It will remain disconnected until power is restored at which time it will wait five minutes to re-synchronize to TEP/UES's system):



1. Determine whether the TEP/UES circuit is energized or de-energized.
2. If TEP's circuit has been continuously energized, then the customer will not attempt to reconnect their system in parallel with the utility until the cause of a protective device misoperation has been corrected by a certified person and TEP/UES has inspected and is satisfied that the customer's system is operating properly.
3. If it is determined that the TEP/UES circuit is de-energized, the customer must not attempt to reconnect their system until it is confirmed by TEP/UES that power has been restored and TEP/UES's circuit is energized.
4. The customer is not prohibited from isolating their system from TEP/UES and supplying their own premise wiring while TEP/UES's circuit is de-energized.

(d) The customer is responsible for damage caused to other customers and to TEP/UES as a result of improper operation or malfunction of their generation facilities.

(e) TEP/UES is not responsible for damage caused to other customers and to TEP/UES as a result of improper operation or malfunction of the customer's generation facilities.

(f) The customer shall delay reconnection of its generation facilities to TEP/UES for a minimum of one minute after the TEP/UES voltage and frequency are restored to normal. TEP/UES is not responsible for damage caused to the customer's facility as a result of TEP/UES's automatic or manual reclosing of its distribution feeder breaker or recloser.

FORMERLY SR-1.23, SECTION 100

		INITIATED BY	DM	REVISION NO.	0	SR-703 Pg. 5 of 6
		ESR COMM.	9-17	ESR COMM.	-	
				EFFECTIVE DATE	-	

SERVICE CONNECTION DETAIL THREE PHASE COMMERCIAL

DRAWING 1

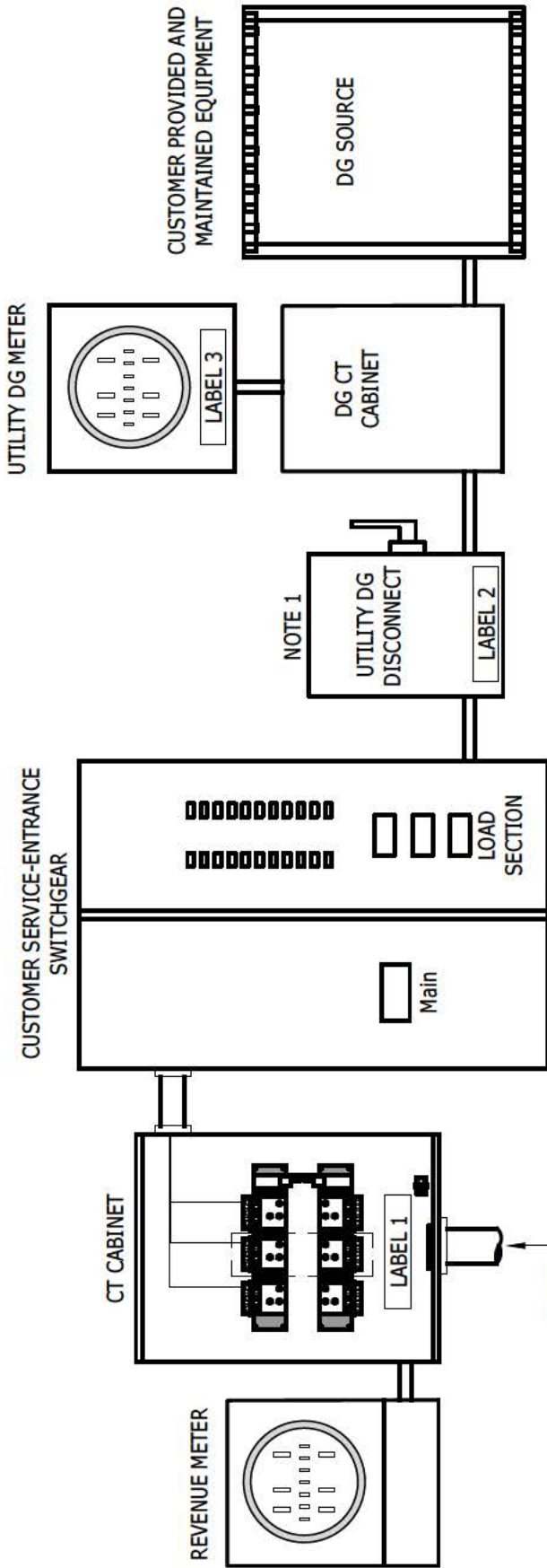

NOTES:

1. IF USING A LINE-SIDE TAP CONNECTION, DG DISCONNECT SWITCH MUST BE APPROPRIATELY FUSED.
2. CUSTOMER SHALL FURNISH AND INSTALL THE DG DISCONNECT SWITCH, DG METER SOCKET (SEE SR-452), LABELS 1-3 AND RELATED DG EQUIPMENT.
3. REVENUE AND DG METERS ARE PROVIDED AND INSTALLED BY TEP/UES.
4. A TEP/UES RENEWABLE ENERGY DEPARTMENT INSPECTION IS REQUIRED FOR APPROVAL.
5. A GOVERNMENTAL AGENCY CLEARANCE IS REQUIRED FOR ALL DG INSTALLATIONS.
6. LABELS ARE AVAILABLE FOR PURCHASE AT BORDER STATES ELECTRIC 294-1414.

WARNING
ELECTRICAL SHOCK HAZARD
DISTRIBUTED GENERATION
PRESENT
TERMINALS ON LINE AND
LOAD SIDE MAY BE
ENERGIZED

LABEL 1
TUC047-W-AE-X42

WARNING
UTILITY DG DISCONNECT
PANEL MAY BE ENERGIZED BY
UTILITY OR CUSTOMER GENERATION

LABEL 2
TUC046-W-AE-C22

WARNING
DISTRIBUTED GENERATION METER
PANEL MAY BE ENERGIZED BY UTILITY
OR CUSTOMER GENERATION

DG SOURCE
METER
SOCKET
UTILITY SOURCE

LABEL 3
TUC045-W-AE-E12

FORMERLY SR-1.23, SECTION 100



METERING REQUIREMENTS FOR DISTRIBUTED GENERATION FACILITIES LARGER THAN 1MW

PURPOSE

 These electric service requirements detail metering requirements for distributed generation (DG) facilities larger than 1MW. The Arizona Corporation Commission (ACC) requires metering for all DG production sources for annual reporting purposes. Because large DG facilities can significantly affect the Company's grid operations, the Company requires DG production metering that is also capable of providing real-time generation information to its System Control & Reliability office.

EQUIPMENT REQUIREMENTS

1. An ION meter is required for DG metering for generating facilities larger than 1MW. The Service Provider will furnish the ION meter at customer expense.
2. The ION meter interfaces with potential transformers (PT), current transformers (CT), and a communications modem. The Service Provider will furnish these items at customer expense.
3. Customer shall furnish the following equipment to support the DG metering:
 - a. CT cabinet as per SR-422
 - b. Transformer-rated meter socket as per SR-414
 - c. PT enclosure
 - d. Communications equipment enclosure



Alternatively, if customer plans are to furnish DG interconnection switchgear, a suitably sized compartment in the switchgear sufficient to house all of the Company's metering equipment is acceptable.

CONSTRUCTION

1. All conduit connections subject to moisture ingress shall be watertight.
2. All conduit fittings at box or cabinet connection points shall be appropriately bonded.
3. The grounded circuit conductor (neutral) shall not be bonded to the CT cabinet. (Note: This is opposite of the requirement for a neutral-ground bond inside the revenue meter CT cabinet.)
4. An auxiliary 120V_{ac} or 277V_{ac} single-phase 3-wire supply circuit sourced from the service entrance panel, switchboard, or switchgear shall be provided. The circuit shall run from the service entrance to the communications equipment enclosure. Alternatively, the circuit may also be derived from any sub-panel that is located on the line (utility) side of the DG disconnect switch. This circuit will provide power to the ION meter during periods when the DG is out of service and the DG disconnect is open.

EQUIPMENT LAYOUT

1. See FIGURE 1 for the required equipment layout when using a CT cabinet and transformer-rated meter socket for DG metering.

		INITIATED BY	EKD	REVISION NO.	1	SR-705 Pg. 1 of 2
		ESR COMM.	11-21	ESR COMM.	8-25	
				EFFECTIVE DATE	8-25	

METERING REQUIREMENTS FOR DISTRIBUTED GENERATION FACILITIES LARGER THAN 1MW

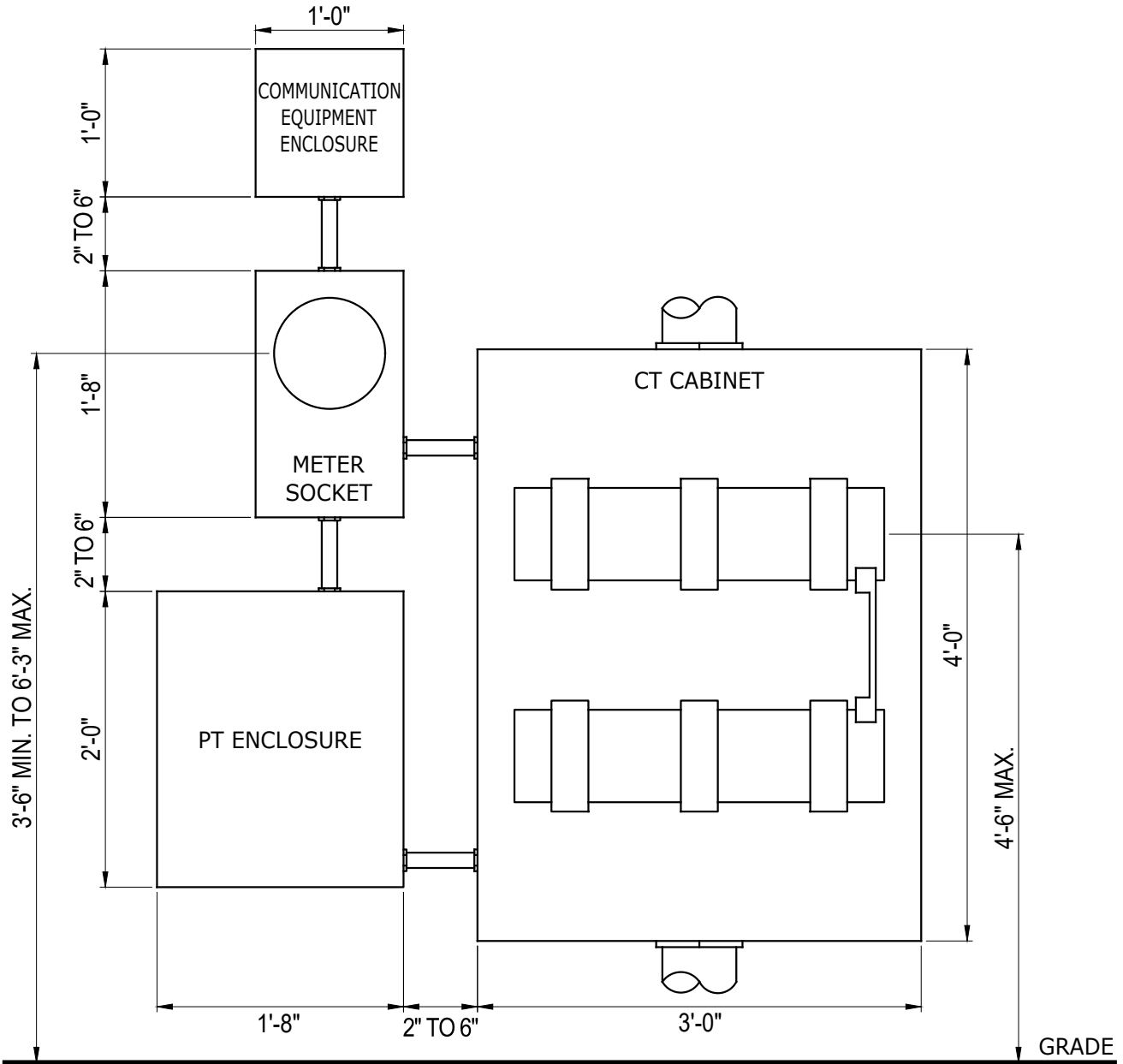

**FIGURE 1
TYPE IV DG METERING LAYOUT**

NOTES:

1. REFER TO SR-422 FOR A LIST OF APPROVE CT CABINETS. ERICKSON CABINET DIMENSIONS, DIFFER FROM EUSERC, BUT ARE APPROVED.
2. ALL METER CONDUIT, SHALL BE 1 1/4", IMC OR RMC.
3. ALL CONDUIT CONNECTIONS, SUBJECT TO MOISTURE INGRESS, SHALL BE WATER TIGHT.
4. METERING SOCKET, SHALL BE A MILBANK, CATALOG # UC7461-YL-TGE-DES.
5. PT ENCLOSURE, SHALL BE A HOFFMAN, CATALOG # A24R208HCR.
6. COMMUNICATION EQUIPMENT, SHALL BE A HOFFMAN, CATALOG # A12R128HCR.
7. COMPANY METERING DEPARTMENT, TO FURNISH AND INSTALL, CT's, PT's, METER AND MODEM COMPONENTS.

		INITIATED BY	EKD	REVISION NO.	1	SR-705 Pg. 2 of 2
		ESR COMM.	11-21	ESR COMM.	8-25	
				EFFECTIVE DATE	8-25	

BACKUP GENERATOR CONNECTION REQUIREMENTS



1. PURPOSE

These electric service requirements include information for use by the Service Provider and customers for connection and operation of customer-owned backup generation. The requirements presented are to ensure the safety of both utility and customer personnel and property.

2. APPLICABILITY

This document applies to all single-phase residential backup generation operating as optional standby systems as defined by the National Electrical Code (NEC) Article 702. Emergency generation systems and legally required standby systems are more complex and will require individual review by Service Provider engineering.

3. DEFINITIONS

Optional Standby Systems: Those systems intended to supply power to public or private facilities or property where life safety does not depend on the performance of the system. These systems are intended to supply on-site generated power to selected loads either automatically or manually. (Definition verbatim from NEC Article 702.2)

Transfer Switch: Source transfer equipment which may be designed to be automatically or manually operated for the purpose of transferring electrical load from one power source to another.

Utility Isolation Disconnect: A means to isolate the utility from customer-owned generation grid back feed that is (1) installed and maintained by the customer, (2) a visible-open, manual gang-operated, load break device, and (3) capable of being locked in the visible-open position by a standard Service Provider padlock.

4. STANDARDS

All customer equipment shall conform to the nationally-recognized standards and recommended practices. These include, but are not limited to the following:

- (a) NFPA 70 - National Electrical Code (NEC)
- (b) UL 1008 - Standard for Safety, Transfer Switch Equipment

5. SERVICE PROVIDER DESIGN REVIEW AND APPROVAL

Prior to installation of customer generation facilities, customer shall submit a New Construction Application to the Service Provider Design Services Department for review and written approval. Application forms may be found on the Service Provider's website. Documentation to be furnished with the application includes transfer switch product documentation and an electrical one-line diagram depicting the connection of the transfer switch and generator in relation to the electrical service to the premise. Following approval, customer shall not remove, alter, modify, or change the equipment specifications and/or the electrical connection configuration. If the customer desires to make such changes or modifications, they must revise and resubmit plans describing the changes or modifications for approval.



		INITIATED BY	EKD	REVISION NO.	1	SR-709 Pg. 1 of 7
		ESR COMM.	7-20	ESR COMM.	6-23	
				EFFECTIVE DATE	6-23	

BACKUP GENERATOR CONNECTION REQUIREMENTS



6. TECHNICAL REQUIREMENTS

- a. Backup generators used to supply all, or part, of a customer's load during an emergency power outage shall be connected to the customer's wiring through a double-throw, open-delayed transition (break-before-make) transfer switch specifically designed and installed for that purpose. For generation systems intended to serve the entire facility load, the transfer switch must be service-entrance rated.
- b. Transfer switch operation mode may be either automatic or manual.
- c. Transfer switch switching mechanism may be a contactor or a molded-case, or power-case, switch.
- d. Regardless of transfer direction, utility to generator or generator to utility, the transfer switch shall always disconnect customer load from its supply prior to switching to the other supply source.
- e. A dedicated disconnect switch with a visible-open air-gap shall be installed between the transfer switch and the utility source connection. Disconnect switch warning label shall be as shown in below Section 7.b.
- f. The disconnect switch shall be installed in a readily accessible location to provide safe, easy, unrestricted, and unimpeded access for Service Provider personnel at all times. It shall be installed within 10 feet of the service entrance, unless Service Provider has been contacted and approved a Customer variance request to install it elsewhere. Any variance granted does not alter the requirement that the disconnect switch be readily accessible.
- g. The disconnect switch shall be visible-open such that the switch blades, jaws, and the air-gap between them are clearly visible when the switch is in the "open" position and the front cover of the switch box is opened. The switch handle shall be capable of being locked in the "open" position by a standard Service Provider padlock with a 3/8" shank. The switch front cover shall be kept locked at all times by a Service Provider-furnished padlock. The front cover hasp shall be capable of accepting a 3/8" shank padlock, and shall not be field modified in any way.
- h. The disconnect switch shall be installed securely on a rigid operating surface such as the side of a building, wall, or Unistrut rack so that operation of the switch handle does not cause movement or flexing of the switch enclosure. Mounting height shall be such that the center line of the switch handle is between 42 inches and 75 inches above final grade. Working space requirements are as per the NEC.
- i. The disconnect switch shall be connected so that the blades (and any fuses present) are de-energized when the switch is in the "open" position in accordance with NEC Article 404.6(C). For a typical disconnect switch arrangement, this means that the switch blades will connect to the transfer switch while the switch jaws will connect to the source of utility supply.
- j. If the disconnect switch connection to the source of utility supply is on the supply side of the main service disconnecting means, the disconnect switch must be fused. Fuses shall be sized based on voltage and current ratings of the generation system. The disconnect switch shall be rated to withstand the available fault current duty.
- k. Means of connection of the transfer switch utility-fed circuit to the customer service panel must not void any listing agency approval for the service panel. For example, lifting the factory-installed wires connecting the meter socket to the main breaker in an all-in-one combination service panel is not allowed unless the panel manufacturer provides verification that such a modification will not compromise the panel listing. (See Figures 1 through 4 for sample one-line diagrams for allowed and disallowed systems.)



		INITIATED BY	EKD	REVISION NO.	1	SR-709 Pg. 2 of 7
		ESR COMM.	7-20	ESR COMM.	6-23	
				EFFECTIVE DATE	6-23	

BACKUP GENERATOR CONNECTION REQUIREMENTS



7. PLACARDS/ WARNING SIGNS

- a. Backup generators that operate in open transition mode by means of an automatic transfer switch as described herein are required to include a warning sign located at the customer service entrance. The warning sign (LABEL 1) is available at Border States Electric. Customer will be responsible for purchase and installation. Inspection of sign installation will be completed by Design Services prior to energization of the system.
- b. The utility isolation disconnect switch installed between the transfer switch and the utility supply source shall be required to include a warning sign located at the disconnect switch. The warning sign (LABEL 2) is available at Border States Electric. Customer will be responsible for purchase and installation. Inspection of sign installation will be completed by Design Services prior to energization of the system.

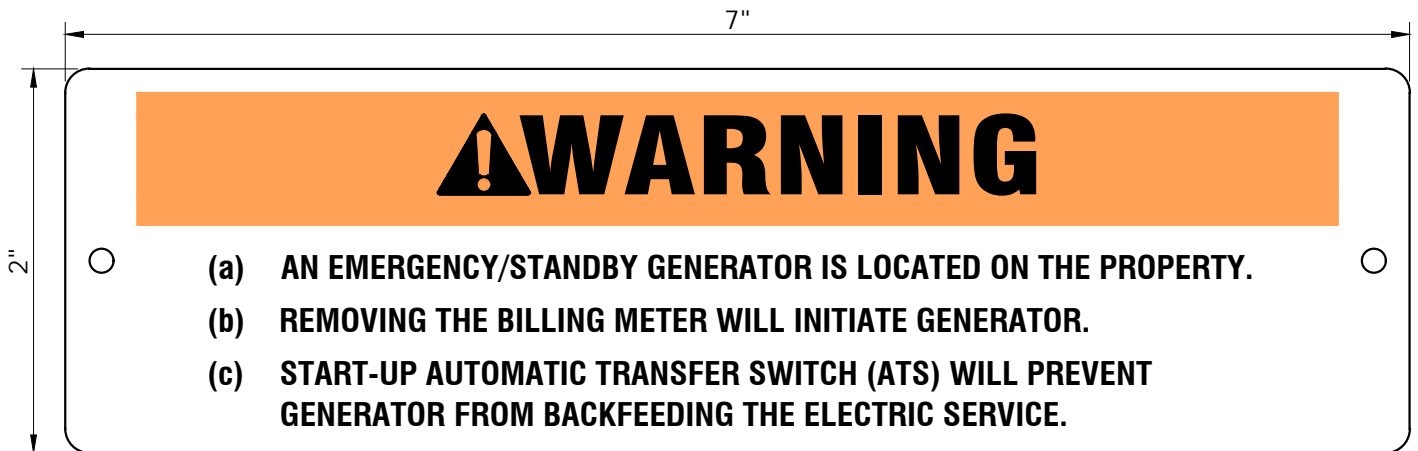

LABEL 1

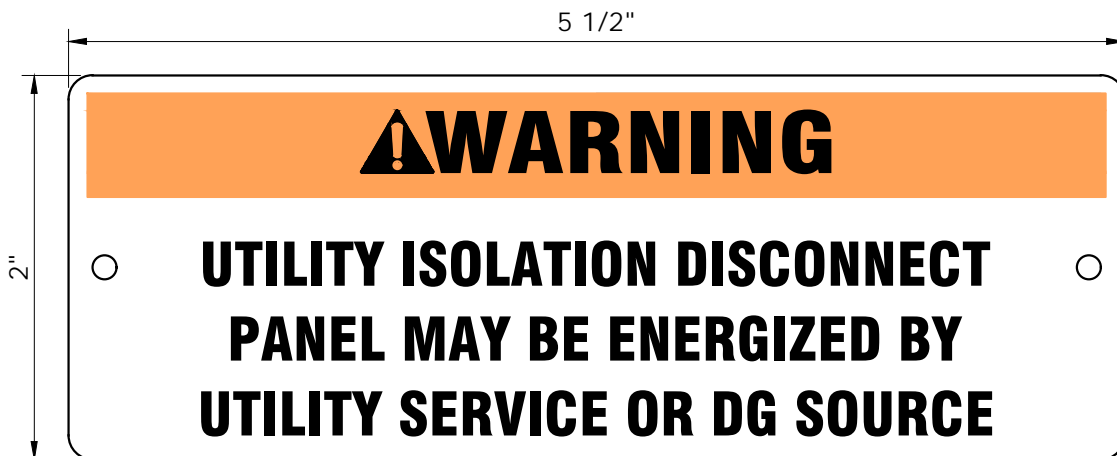

LABEL 2

		INITIATED BY	JAB	REVISION NO.	0	SR-709 Pg. 3 of 7
		ESR COMM.	6-23	ESR COMM.	-	
				EFFECTIVE DATE	6-23	

BACKUP GENERATOR CONNECTION REQUIREMENTS



CONFIGURATION FOR 100% BACKUP- REVENUE METER WITH SEPARATE LOAD CENTER

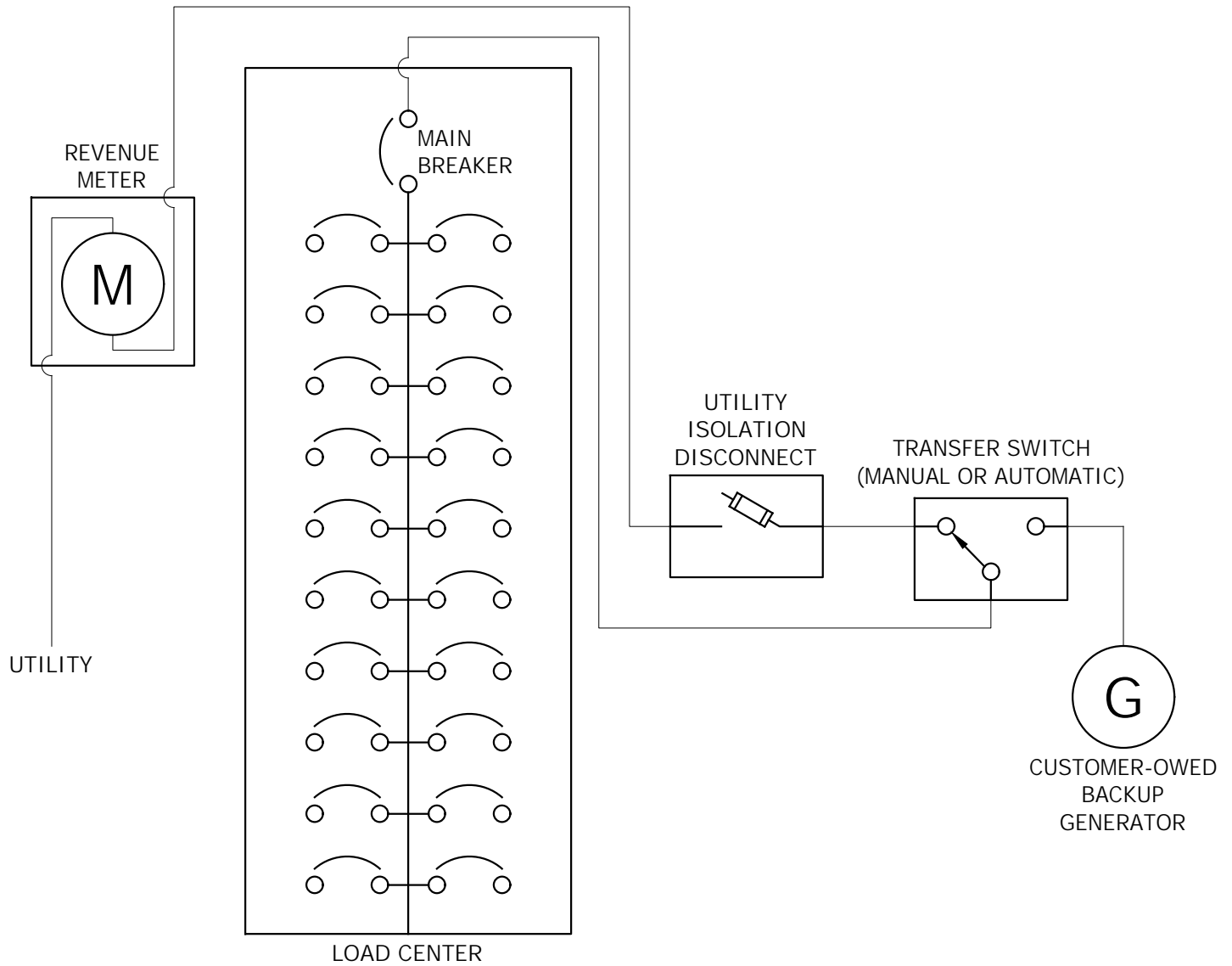

FIGURE 1

BACKUP GENERATOR CONNECTION REQUIREMENTS



ALTERNATE CONFIGURATION FOR 100% BACKUP- REVENUE METER WITH SEPARATE LOAD CENTER

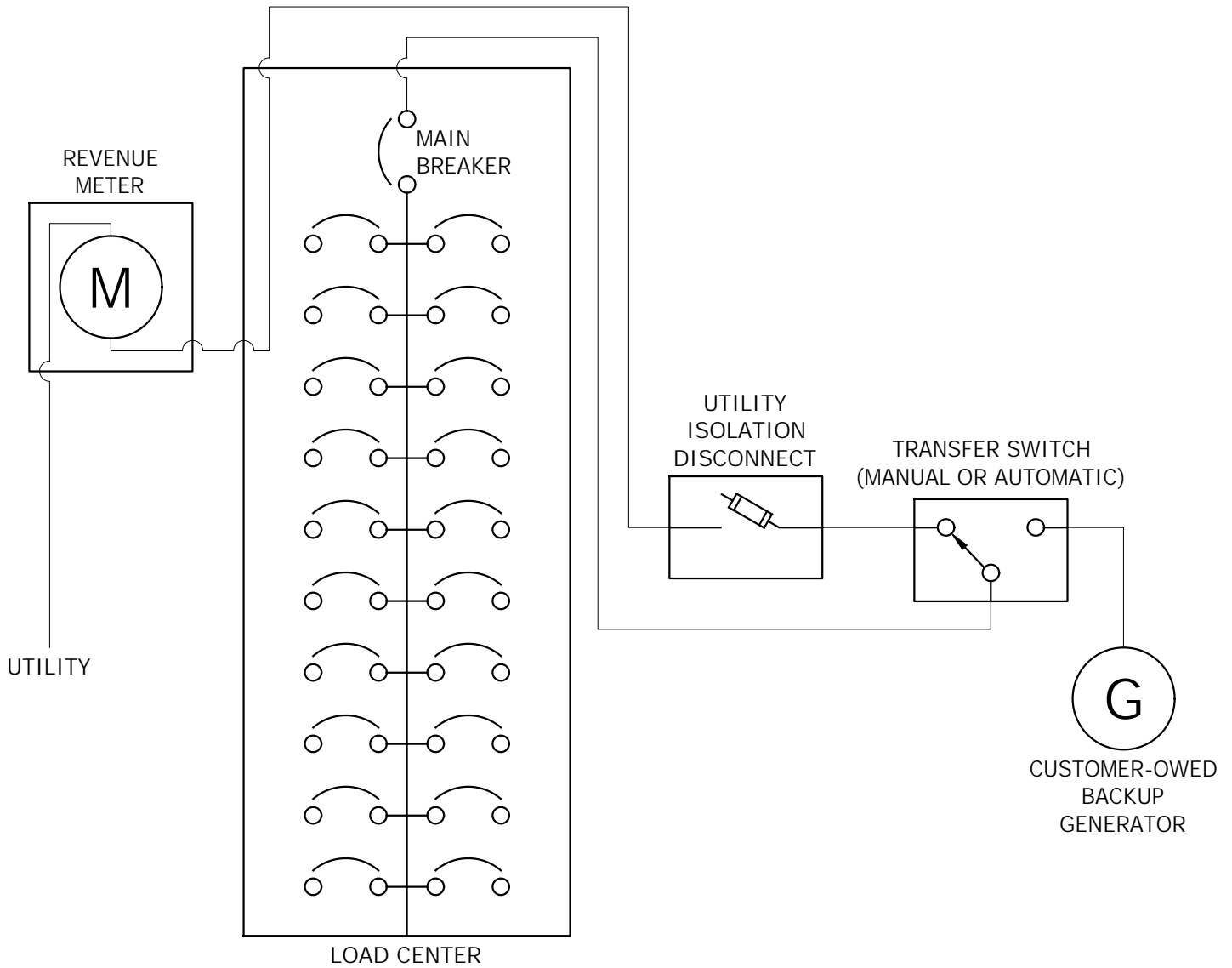

FIGURE 2

BACKUP GENERATOR CONNECTION REQUIREMENTS



CONFIGURATION WITH BACKUP LOADS PANEL

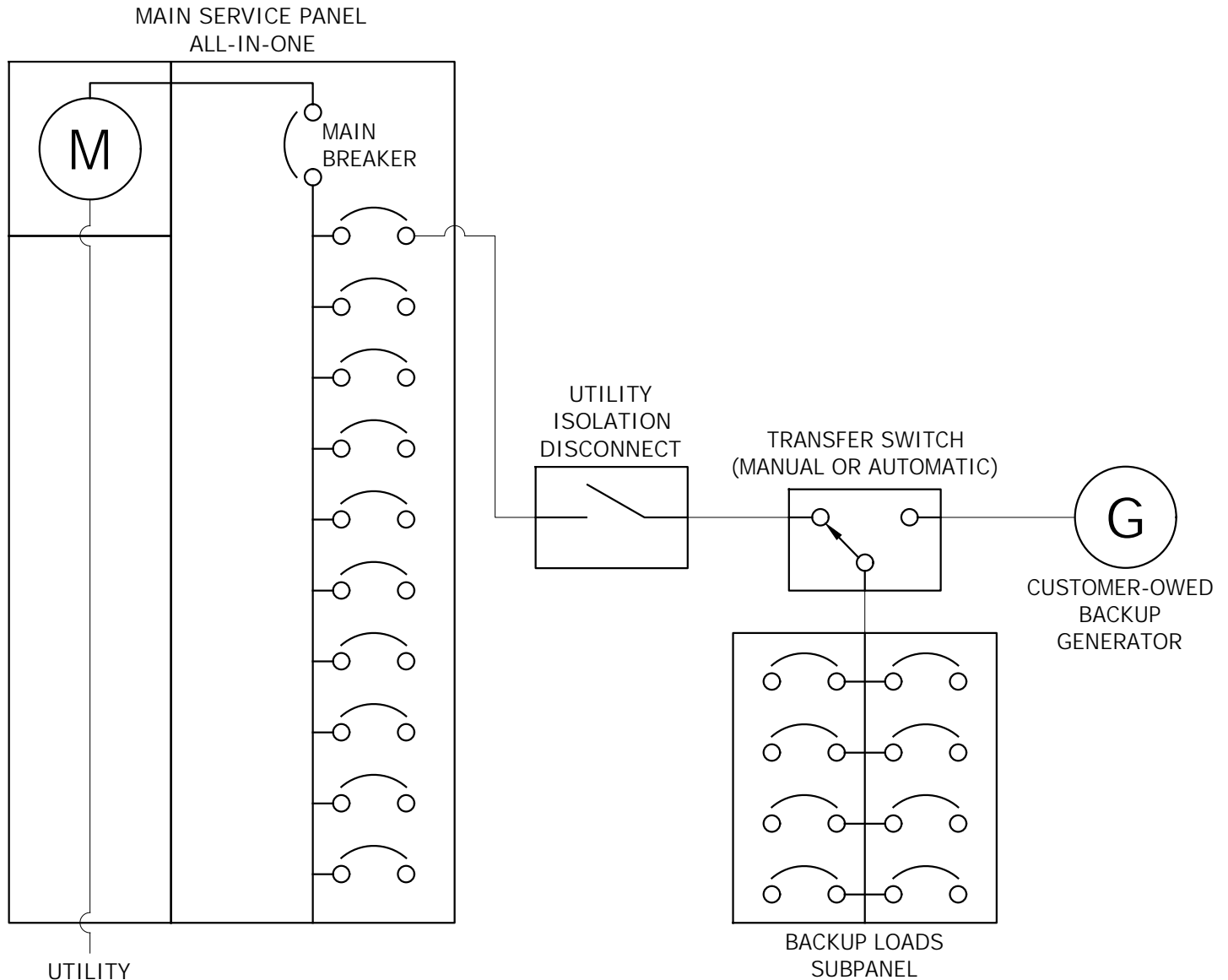

FIGURE 3

BACKUP GENERATOR CONNECTION REQUIREMENTS



CONFIGURATION FOR 100% BACKUP, ALL-IN-ONE COMBINATION PANEL

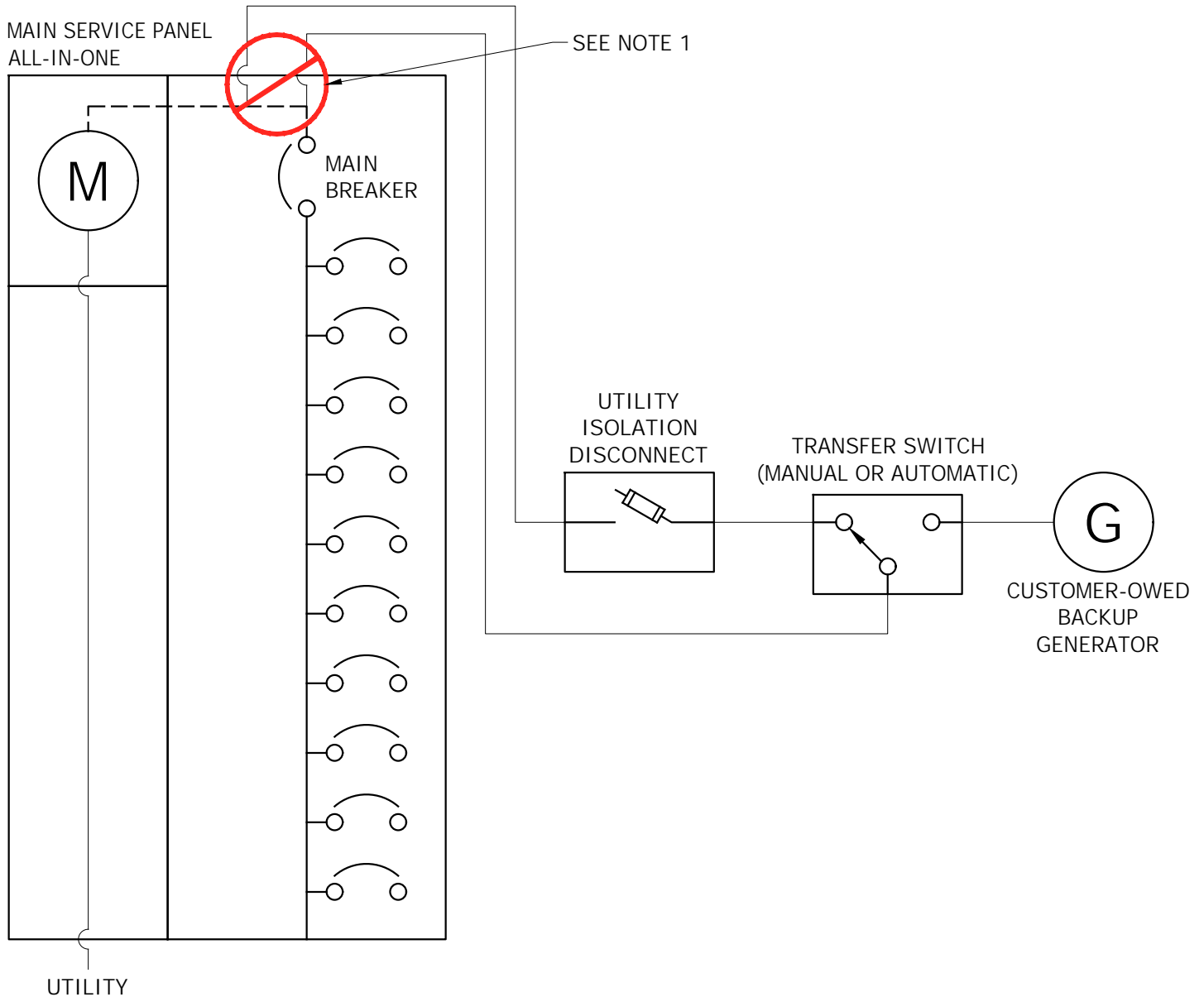

FIGURE 4

NOTE:

1. THE LIFTING OF FACTORY-INSTALLED JUMPERS BETWEEN METER AND MAIN BREAKER OR ANY PANEL MODIFICATION IS NOT ALLOWED WITHOUT MANUFACTURER VERIFICATION THAT THIS DOES NOT VOID PANEL LISTING.

INTERCONNECTION REQUIREMENTS - DISTRIBUTED ENERGY STORAGE SYSTEMS, SINGLE-PHASE

1. Table of Contents

General Application

- Purpose - Pg. 1
- Applicability - Pg. 1
- Definitions - Pg. 1
- Standards - Pg. 3
- Service Provider Design Review and Approval - Pg. 4
- Technical Requirements - Pg. 4
- Customer Operating Requirements - Pg. 5

DC Coupled Configuration #1

- Metering Requirements - Pg. 6
- Disconnect Switches - Pg. 6
- Configuration Layout Diagram - Pg. 8

DC Coupled Configuration #2

- Metering Requirements - Pg. 9
- Disconnect Switches - Pg. 10
- Configuration Layout Diagram - Pg. 11

AC Coupled Configuration

- Metering Requirements - Pg. 12
- Disconnect Switches - Pg. 12
- Configuration Layout Diagram - Pg. 14

Stand-Alone

- Disconnect Switch - Pg. 15
- Configuration Layout Diagram - Pg. 16

2. Purpose



These electric service requirements include information for use by the Service Provider and customers for interconnection and parallel operation of small inverter-based, distributed energy storage system (ESS) sources with the Service Provider's distribution system. The document is an application of SR-701 "GENERAL REQUIREMENTS FOR CUSTOMER INSTALLATION AND OPERATION OF DISTRIBUTED GENERATION SOURCES" along with the "DISTRIBUTED GENERATION INTERCONNECTION REQUIREMENTS (DGIR)" as filed with and approved by the Arizona Corporation Commission (ACC). The requirements presented are to ensure the safety of both utility and customer personnel and property.

3. Applicability

This document applies to all single-phase, inverter-based, energy storage systems capable of parallel operation with the Service Provider's distribution system. It pertains only to interconnection with single-phase, 120/240V, 3-wire services.

4. Definitions

AC Coupled: An energy storage system that is connected to an AC point of coupling with the service provider.

 	INITIATED BY	JRO	REVISION NO.	0	SR-710 Pg. 1 of 16
	ESR COMM.	12-18	ESR COMM.	-	
			EFFECTIVE DATE	1-19	

INTERCONNECTION REQUIREMENTS - DISTRIBUTED ENERGY STORAGE SYSTEMS, SINGLE-PHASE

4. Definitions (cont'd)

Automatic Transfer Switch (ATS): An open transition transfer switch, that will automatically disconnect a generating facility and/ or energy storage system, from the service provider in the event of the loss of distribution system voltage. ATS may be internal to Multimode inverters or an external device that is installed separately.

Backed Up Loads: The loads that an energy storage system with a multimode inverter will supply electricity to in the event of a service provider outage.

Backed Up Loads Disconnect Switch: A visible open disconnect device that the customer is required to install and maintain in accordance with the requirements herein. It will de-energize the Backed Up Loads meter and associated equipment.

Backfeed: To energize a section of the Service Provider's distribution system from a source of electric supply other than the Service Provider.

DC Coupled: An energy storage system that is connected to the DC point of coupling of the Distributed Generation.

Distributed Energy Resource (DER): Any resource on the distribution system that produces electricity, such as distributed energy storage and distributed generation.

Distributed Energy Storage: Any type of customer energy storage system interconnected with the distribution system that either (1) has the capability of being operated in electrical parallel with the distribution system or (2) can feed a customer load that can also be fed by the distribution system.

Distributed Generation (DG): Any type of customer electrical generator, static inverter, or generating facility interconnected with the distribution system that either (1) has the capability of being operated in electrical parallel with the distribution system or (2) can feed a customer load that can also be fed by the distribution system.

Distributed Generation Interconnection Requirements (DGIR): Document conformed to ACC Docket No. E-00000A-99-0431 Decision No. 69674, dated June 28, 2007, that describes, procedural, administrative, and technical requirements for the interconnection of DG to the Service Provider's distribution system for the purpose of parallel operation. DGIRs can be found at <https://www.tep.com/wp-content/uploads/2016/04/dgir.pdf>



Distribution System: The infrastructure constructed, maintained, and operated by the Service Provider to deliver electric service to retail customers at primary and secondary distribution voltages (13.8kV and less).

Energy Storage System: One or more components capable of storing energy, to later be used in parallel with, or independent of, the Service Provider. For the purposes of this document, only those energy storage systems utilizing Interactive or Multimode Inverters shall be acceptable for interconnection with the Service Provider.

Generating Facility: All or part of the customer's electrical generator(s) and/or inverter(s) together with all protective, safety, and associated equipment necessary to produce electric power at the customer's facility.

Inverter: A power electronic device that converts DC power to AC by means of electronic switching.

- (a) **Interactive Inverter:** An inverter for use in parallel with the Service Provider to supply common loads and may deliver power to the Service Provider. May also be referred to as a grid-tied inverter.
- (b) **Multimode Inverter:** Equipment having capabilities of both the interactive inverter and the stand-alone inverter.
- (c) **Stand-Alone Inverter:** An inverter that only supplies power independent of the service provider.

		INITIATED BY	JRO	REVISION NO.	0	SR-710 Pg. 2 of 16
		ESR COMM.	12-18	ESR COMM.	-	

INTERCONNECTION REQUIREMENTS - DISTRIBUTED ENERGY STORAGE SYSTEMS, SINGLE-PHASE

4. Definitions (cont'd)

Island: A condition in which a portion of the Service Provider's distribution system is energized solely by one or more customer DER through the associated point(s) of interconnection while that portion of the Service Provider distribution system is electrically separated from the rest of the Service Provider distribution system.

Line Side (Supply Side) Interconnection: Interconnection of the customer DER between the Service Provider revenue meter and the customer main service disconnect(s).

Load Side Interconnection: Interconnection of the customer energy storage input or output at an over-current protective device in the customer load center or sub-panel.

Parallel System: A customer's energy resource that is electrically interconnected to a bus common with the Service Provider distribution system, either on a momentary or continuous basis.

Point of Coupling: The physical location where the energy storage system is connected to the customer's DG.

Point of Interconnection: The physical location where the DER conductors are connected to the customer's service. See SR-702 for information regarding requirements of various methods of interconnection.



Service Provider: A regulated electric utility that furnishes electric power and associated metering services to retail electrical customers in its defined service area. For purposes of this document, Service Provider will connote either Tucson Electric Power Company or Unisource Energy Services.

Utility Isolation Disconnect Switch: A visible open disconnect device that the customer is required to install and maintain in accordance with the requirements herein. It will completely isolate the customer's distributed energy resources from the Service Provider grid.

5. Standards

All customer equipment shall conform to the nationally-recognized standards and recommended practices and latest revision. These include, but are not limited to the following:

- (a) NFPA 70 - National Electrical Code (NEC)
- (b) IEEE 1547 - Standard for Interconnecting Distributed Resources with Electric Power Systems
- (c) IEEE 1547.1 - Standard for Conformance Test Procedures for Equipment Interconnecting Distributed Resources with Electric Power Systems.
- (d) IEEE 519 - Recommended Practices and Requirements for Harmonic Control in Electrical Power Systems
- (e) ANSI C84.1 - Electric Power Systems and Equipment-Voltage Ratings (60Hz)
- (f) UL 1741 - Inverters, Converters, Controllers and Interconnection System Equipment for Use with Distributed Energy Resources
- (g) UL 1642 - Standard for Lithium Batteries
- (h) UL 9540 - Standard for Energy Storage Systems and Equipment
- (i) UL 1973 - Standard for Batteries for Use in Light Electric Rail (LER) Applications and Stationary Applications

		INITIATED BY	JRO	REVISION NO.	0	SR-710 Pg. 3 of 16
		ESR COMM.	12-18	ESR COMM.	-	
			EFFECTIVE DATE		1-19	

INTERCONNECTION REQUIREMENTS - DISTRIBUTED ENERGY STORAGE SYSTEMS, SINGLE-PHASE

6. Service Provider Design Review and Approval

Prior to installation of customer interconnection facilities, customer shall submit an interconnection application to the Service Provider for review and written approval. Application forms may be found on the Service Provider's website. Documentation to be furnished with the application may include an electrical one-line diagram, an electrical three-line diagram, site plan, equipment elevation drawings and control specifications. Utility review and inspection may be required for approval. Following approval, customer shall not remove, alter, modify, or change the equipment specifications, including, without limitation, the plans, control and protective devices or settings, and the generating facility system design, type, size, or configuration. If the customer desires to make such changes or modifications, they must revise and resubmit plans describing the changes or modifications for approval. No such change or modification may be made without prior approval.

7. Technical Requirements

(a) Line Side Interconnections

For line side interconnections, as are permitted by the NEC, the following requirements apply:



- (1) A line side interconnection constitutes a new service and is subject to all applicable NEC requirements and/or requirements adopted by the local code-enforcement authority.
- (2) Customer is required to arrange a power-kill with Service Provider to de-energize customer equipment before performing line side interconnection work. The Service Provider will energize this service only after the facility has passed the inspection of the applicable government agency and notification has been received by the Service Provider as is described in the process for new services elsewhere in these Service Requirements.
- (3) Any line side interconnection shall be made without modifications to any factory installed and/or factory listed equipment or components. Please contact Service Provider Design Department for additional guidance regarding this matter.
- (4) For 200A Milbank meter sockets only, customer may install Milbank tap connectors, Catalog No. KA77-INT, to complete the line side interconnection inside the revenue meter base enclosure.

(b) Minimum Protective Requirements

- (1) Inverter shall be set to detect and trip for any abnormal operating condition on the Service Provider's system, unless isolated.
- (2) Circuit breakers, if backfed, shall be suitable for such operation.
- (3) Inverters shall be tested to UL 1741 by a Nationally Recognized Testing Laboratory (NRTL) certified by OSHA to perform the UL 1741 test standard.

(c) Distribution Transformer

- (1) Customer's single-phase DERs can only be connected to the Service Provider's single-phase distribution transformers.
- (2) Customer DG with a combined total rating of over 10kWAC, as measured at the service entrance, will be required to be isolated from other customers served from the same Service Provider transformer. This will be accomplished by installing a separate dedicated transformer to serve only the customer with DG in excess of 10kWAC. All work necessary to modify existing Service Provider facilities to accommodate customer-owned DG shall be done at the customer's expense.
- (3) Customer energy storage systems with a combined total rating of over 10kWAC, as measured at the service entrance, will be subject to engineering review.

		INITIATED BY	JRO	REVISION NO.	0	SR-710 Pg. 4 of 16
		ESR COMM.	12-18	ESR COMM.	-	
			EFFECTIVE DATE		1-19	

INTERCONNECTION REQUIREMENTS - DISTRIBUTED ENERGY STORAGE SYSTEMS, SINGLE-PHASE

8. Customer Operating Requirements

This section provides operating requirements that the customer must follow and responsibilities that the customer must assume to operate their energy storage system in parallel with the Service Provider system.

(a) Quality of service

The operation of the customer's energy storage system must not reduce the quality of service of the distribution system to other Service Provider customers. No abnormal voltages, currents, frequencies, or interruptions are permitted.

(b) De-energized Service Provider circuit

The customer will at no time energize a de-energized Service Provider circuit.



(c) Inhibited Parallel Operation

(1) If the Service Provider circuit is de-energized, the inverter shall not attempt to reconnect their system until power has been restored. The inverter shall delay reconnection for a parallel operation of its generating facilities for a minimum of five minutes after the Service Provider voltage and frequency are restored to normal. Service Provider is not responsible for damage caused to the customer's facilities as a result of automatic or manual reclosing of distribution feeder breakers or reclosers.

(2) The customer is not prohibited from isolating their system from the Service Provider and supplying their own premise wiring while the Service Provider's circuit is de-energized.

(d) Customer Responsibility for Damage Caused by Customer Energy Storage Systems

The customer is responsible for damage caused to other customers and to the Service Provider as a result of improper operation or malfunction of their energy storage system.

		INITIATED BY	JRO	REVISION NO.	0	SR-710 Pg. 5 of 16
		ESR COMM.	12-18	ESR COMM.	-	
				EFFECTIVE DATE	1-19	

INTERCONNECTION REQUIREMENTS - DISTRIBUTED ENERGY STORAGE SYSTEMS, SINGLE-PHASE

9. Metering Requirements for DC Coupled Configuration #1

(a) General

The customer shall provide and install a meter socket, in accordance with Service Provider requirements, to meter the generator output. This is referred to as the production or DG meter socket. Equipment should be selected from the approved material list in SR-452. (At present, for residential single-phase DG systems only, Service Provider will furnish a DG meter socket to the customer if they so request.) Service Provider will furnish and install the DG meter.

Under no circumstances shall any metering enclosure be used as a conduit or raceway for any conductors other than those phase conductors being metered and the associated grounded conductor (neutral) and grounding conductor (equipment ground). A neutral must be run from the customer service to the DG meter socket and terminated on the neutral bus for DG systems that may not require a neutral to operate.

Backed up loads must be served via customer's main service panel during normal grid operation, and must contain a transfer switch. See page 8 of this document for approved DC Coupled layout and SR-702 for DG metering requirements

No loads, technologies, or strategies not related to the customer's generating facility may divert, for any purpose, DG energy that would otherwise have been metered as DG production.

(b) Arrangement and Location



The DG meter shall be located within 10 feet of the revenue meter, within line of sight and not separated by walls, gates or obstructions. Variances are not granted based on convenience or preference and must be submitted in the interconnection application and subsequently approved prior to construction. Meter sockets shall be accessible to Service Provider personnel at all times.

(c) Meter Socket Identification

The DG meter socket shall be labeled "Distributed Generation Meter" and shall employ signage as shown in page 8 of this SR. Service Provider will furnish the required warning placards to the customer, for approved projects, through their distributor, Border States Electric.

(d) Meter Socket Heights

Minimum and maximum meter socket heights shall be as specified in SR-405 page 2.

(e) Equipment Protection and Grounding

Meter sockets and all related metering enclosures and equipment shall be grounded in accordance with the NEC and any applicable local codes. In addition, Service Provider requires bonding at all box connectors by use of bonding bushings.

(f) Working Space



Working space requirements for all metering equipment shall be as specified in SR-405 page 10.

10. Disconnect Switches for DC Coupled Configuration #1

(a) General

For energy storage systems with Multimode Inverters, the utility isolation disconnect must be installed between the load side or line side Point of Interconnection and the Multimode Inverter.

As required by the DGIR, the customer shall install a Utility Isolation disconnect switch to isolate all ungrounded conductors of the DERs from the Service Provider System. The switch shall be a gang-operated, load-break device with a visible air-gap in the open position. It shall be rated for the current and voltage requirements of the energy storage system and shall be lockable in the open position.

 	INITIATED BY	JRO	REVISION NO.	1	SR-710 Pg. 6 of 16
	ESR COMM.	12-18	ESR COMM.	3-24	
			EFFECTIVE DATE	3-24	

INTERCONNECTION REQUIREMENTS - DISTRIBUTED ENERGY STORAGE SYSTEMS, SINGLE-PHASE

10. Disconnect Switches for DC Coupled Configuration #1 (cont'd)

For residential single-phase DG systems requesting load side interconnection only, the Service Provider will furnish both DG disconnect switches to the customer, if they so request.

Under no circumstances shall any disconnect switch enclosure be used as a conduit or raceway for any conductors other than the phase conductors, associated grounded conductor (neutral) and associated grounding conductor (equipment ground) of the energy storage output circuit. All phase conductors shall be terminated on appropriate terminals inside the switch enclosure.

(b) Arrangement and Location



The Utility Isolation disconnect switch and all required meter switches shall be located within 10 feet of the customer's revenue meter, within line of sight, not separated by walls, gates or obstructions, and installed between the DERs and the point of interconnection.

Variances are not granted based on convenience or preference and must be requested in the interconnection application and subsequently approved prior to construction. Switch installations shall be accessible and operable to Service Provider personnel at all times.

See page 8 for layout details.

(c) Labeling



The disconnect switch shall be labeled "Utility Isolation Disconnect" and shall employ signage as shown in page 8 of this SR. Service Provider will furnish the required warning label to the customer through their distributor, Border States Electric.

(d) Disconnect Switch Heights

Minimum and maximum disconnect heights shall match the requirements for meter socket heights as specified in SR-405 page 2.

(e) Equipment Protection and Grounding

Disconnect switch enclosures shall be grounded in accordance with the NEC, any applicable local codes. In addition, Service provider requires bonding at all box connectors by use of bonding bushings.

 	INITIATED BY	JRO	REVISION NO.	1	SR-710 Pg. 7 of 16
	ESR COMM.	12-18	ESR COMM.	3-24	
			EFFECTIVE DATE	3-24	

DC-COUPLED CONFIGURATION #1 INTERCONNECTION LAYOUT SINGLE-PHASE SERVICE

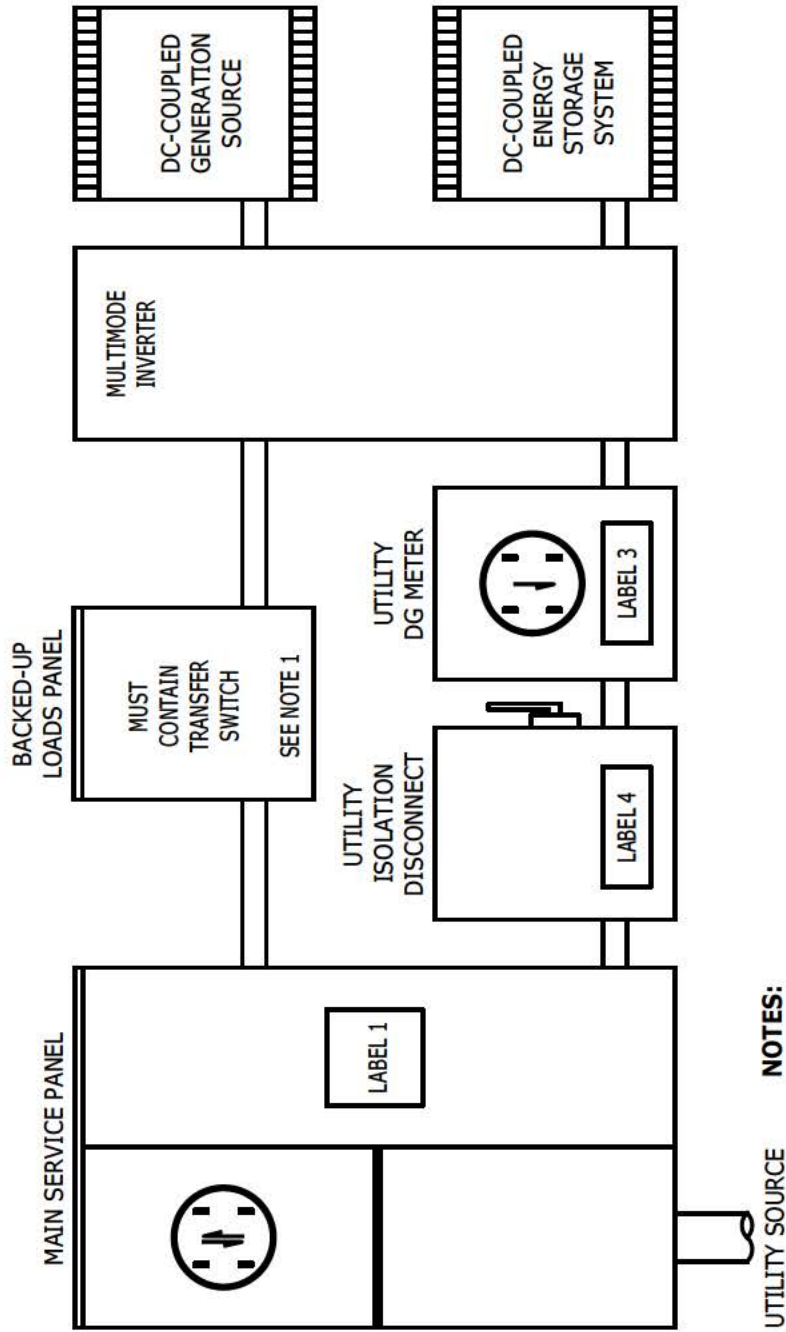

NOTES:

1. BACKED-UP LOADS PANEL MUST BE SERVED VIA CUSTOMER'S MAIN SERVICE PANEL DURING NORMAL GRID OPERATION.
2. MULTIMODE INVERTER MUST ISOLATE FROM SERVICE PROVIDER'S SYSTEM DURING BACK-UP MODE.
3. SEE SR-702 PAGE 6 FOR NOTES REGARDING UTILITY DG METER SOCKET AND ISOLATION DISCONNECT.

WARNING
ELECTRICAL-SHOCK HAZARD
DISTRIBUTED GENERATION
PRESENT
TERMINALS ON LINE AND
LOAD SIDE MAY BE
ENERGIZED

LABEL 1
2-15-1912

WARNING
DISTRIBUTED GENERATION METER
PANEL MAY BE ENERGIZED BY UTILITY
OR CUSTOMER GENERATION

LABEL 3
2-15-1911

WARNING
UTILITY ISOLATION DISCONNECT
PANEL MAY BE ENERGIZED BY
UTILITY SERVICE OR DG SOURCE

LABEL 4
2-15-1902

INTERCONNECTION REQUIREMENTS - DISTRIBUTED ENERGY STORAGE SYSTEMS, SINGLE-PHASE

11. Metering Requirements for DC Coupled Configuration #2

(a) General

If the multimode inverter is supplying backed-up loads while operating in parallel with the Service Provider, the customer shall install a meter socket, in accordance with Service Provider requirements, to meter the consumption of the backed-up loads. This meter is referred to as the Backed-Up Loads meter. See page 11 for general layout requirements. Service Provider will furnish and install the Backed-Up Loads meter.

The customer shall install a second meter socket as specified on page 11, in accordance with Service Provider requirements, to provide bidirectional metering of both energy delivered by the multimode inverter to the customer's main service and energy delivered by the Service Provider to the backed-up loads. This meter is referred to as the production or Utility DG meter. Service Provider will furnish and install the DG meter.

Equipment should be selected from the approved material list in SR-452. (At present, for residential single-phase DER systems only, Service Provider will furnish both meter sockets to the customer if they so request).

Under no circumstances shall any metering enclosure be used as a conduit or raceway for any conductors other than those phase conductors being metered and the associated grounded conductor (neutral) and grounding conductor (equipment ground). A neutral must be run from the customer service to the DG meter socket and terminated on the neutral bus for DG systems that may not require a neutral to operate. A neutral must also be run from the multimode inverter to the Backed-Up Loads meter and terminated on the neutral bus for DG systems and loads that may not require a neutral to operate.

No loads, technologies, or strategies not related to the customer's generating facility may divert, for any purpose, DG energy that would otherwise have been metered as DG production.

(b) Arrangement and Location



Both meters shall be located within 10 feet of the revenue meter, within line of sight and not separated by walls, gates or obstructions. Variances are not granted based on convenience or preference and must be submitted in the interconnection application and subsequently approved prior to construction. Meter sockets shall be accessible to Service Provider personnel at all times.

(c) Meter Socket Identification

The Backed-Up Loads meter socket shall be labeled "Backed-Up Loads Meter" and the DG meter socket shall be labeled "Distributed Generation Meter". Both shall employ signage as shown in page 11 of this SR. Service Provider will furnish the required warning placards to the customer, for approved projects, through their distributor, Border States Electric.

(d) Meter Socket Heights



Minimum and maximum meter socket heights shall be as specified in SR-405 page 2.

(e) Equipment Protection and Grounding

Meter sockets and all related metering enclosures and equipment shall be grounded in accordance with the NEC any applicable local codes. In addition, Service Provider requires bonding at all box connectors by use of bonding bushings.

(f) Working Space

Working space requirements for all metering equipment shall be as specified in SR-405 page 10.

 	INITIATED BY	JRO	REVISION NO.	1	SR-710 Pg. 9 of 16
	ESR COMM.	12-18	ESR COMM.	3-24	
			EFFECTIVE DATE	3-24	

INTERCONNECTION REQUIREMENTS - DISTRIBUTED ENERGY STORAGE SYSTEMS, SINGLE-PHASE

12. Disconnect Switches for DC Coupled Configuration #2

(a) General

For energy storage systems with Multimode Inverters, the utility isolation disconnect must be installed between the load side or line side Point of Interconnection and the Multimode Inverter.

As required by the DGIR, the customer shall install a Utility Isolation disconnect switch to isolate all ungrounded conductors of the DERs from the Service Provider System. The switch shall be a gang-operated, load-break device with a visible air-gap in the open position. It shall be rated for the current and voltage requirements of the energy storage system and shall be lockable in the open position.

The customer shall install a Backed-Up Loads disconnect switch to isolate all ungrounded conductors of the DERs from the Backed-Up Loads meter. The switch shall be a gang-operated, load-break device with a visible air-gap in the open position. It shall be rated for the current and voltage requirements of the energy storage system and shall be lockable in the open position.

For residential single-phase DER systems requesting load side interconnection only, the Service Provider will furnish both DG and Backed-Up Loads disconnect switches to the customer, if they so request.

Under no circumstances shall any disconnect switch enclosure be used as a conduit or raceway for any conductors other than the phase conductors, associated grounded conductor (neutral) and associated grounding conductor (equipment ground) of the energy storage output circuit. All phase conductors shall be terminated on appropriate terminals inside the switch enclosure.

(b) Arrangement and Location



The Utility Isolation and Backed-Up Loads disconnect switches and all required meter switches shall be located within 10 feet of the customer's revenue meter, within line of sight and not separated by walls, gates or obstructions. Variances are not granted based on convenience or preference and must be requested in the interconnection application and subsequently approved prior to construction. Switch installations shall be accessible and operable to Service Provider personnel at all times.

The Utility Isolation disconnect switch must be installed between the DERs and the point of interconnection.

The Backed-Up Loads disconnect switch must be installed between the Backed-Up Loads meter and the multimode inverter.

See page 11 for layout details.

(c) Labeling



The Utility Isolation disconnect switch shall be labeled "Utility Isolation Disconnect". The Backed-Up Loads Disconnect shall be labeled "Backed-Up Loads Disconnect". Both shall employ signage as shown in page 11 of this SR. Service Provider will furnish the required warning labels to the customer through their distributor, Border States Electric.

(d) Disconnect Switch Heights

Minimum and maximum disconnect heights shall match the requirements for meter socket heights as specified in SR-405 page 2.

(e) Equipment Protection and Grounding

Disconnect switch enclosures shall be grounded in accordance with the NEC and any applicable local codes. In addition, Service Provider requires bonding at all box connectors by use of bonding bushings.

 	INITIATED BY	JRO	REVISION NO.	1	SR-710 Pg. 10 of 16
	ESR COMM.	12-18	ESR COMM.	3-24	
			EFFECTIVE DATE	3-24	

DC-COUPLED CONFIGURATION #2 INTERCONNECTION LAYOUT SINGLE-PHASE SERVICE

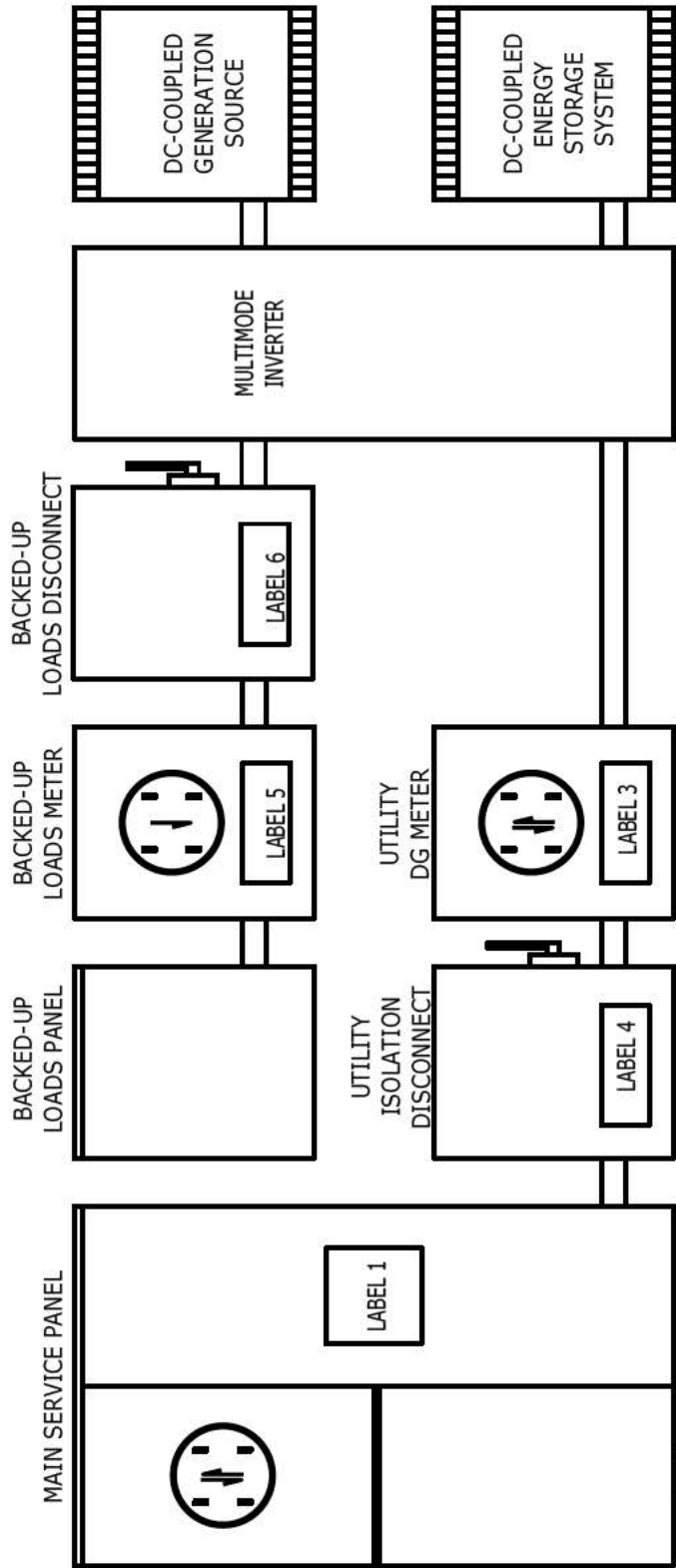

NOTES:

1. BACKED-UP LOADS PANEL MUST BE SERVED VIA CUSTOMER'S MULTIMODE INVERTER DURING NORMAL GRID OPERATION.
2. MULTIMODE INVERTER MUST ISOLATE FROM SERVICE PROVIDER'S SYSTEM DURING BACK-UP MODE.
3. SEE SR-702 PAGE 6 FOR NOTES REGARDING UTILITY DG METER SOCKET AND ISOLATION DISCONNECT.

WARNING
 BACKED-UP LOADS DISCONNECT
 PANEL MAY BE ENERGIZED BY
 UTILITY SERVICE OR DG SOURCE

LABEL 6
2-15-1900

WARNING
 UTILITY ISOLATION DISCONNECT
 PANEL MAY BE ENERGIZED BY
 UTILITY SERVICE OR DG SOURCE

LABEL 4
2-15-1902

WARNING
 BACKED-UP LOADS METER
 PANEL MAY BE ENERGIZED BY
 UTILITY SERVICE OR DG SOURCE

LABEL 5
2-15-1904

WARNING
 DISTRIBUTED GENERATION METER
 PANEL MAY BE ENERGIZED BY UTILITY
 OR CUSTOMER GENERATION

LABEL 3
2-15-1911

WARNING
 ELECTRICAL SHOCK HAZARD
 DISTRIBUTED GENERATION
 PRESENT
 TERMINALS ON LINE AND
 LOAD SIDE MAY BE
 ENERGIZED

LABEL 1
2-15-1912

INTERCONNECTION REQUIREMENTS - DISTRIBUTED ENERGY STORAGE SYSTEMS, SINGLE-PHASE

13. Metering Requirements for AC Coupled Configuration

(a) General

The customer shall provide and install a meter socket, in accordance with Service Provider requirements, to meter the generator output. This is referred to as the production or DG meter socket. Equipment should be selected from the approved material list in SR-452. (At present, for residential single-phase DG systems only, Service Provider will furnish a DG meter socket to the customer if they so request.) Service Provider will furnish and install the DG meter.

Under no circumstances shall any metering enclosure be used as a conduit or raceway for any conductors other than those phase conductors being metered and the associated grounded conductor (neutral) and grounding conductor (equipment ground). A neutral must be run from the customer service to the DG meter socket and terminated on the neutral bus for DG systems that may not require a neutral to operate.

Energy storage systems connected to a service with a DG system must not divert any energy that would be recorded by the DG Meter. See page 14 of this document for approved AC Coupled layout and SR-702 for DG metering requirements.

No loads, technologies, or strategies not related to the customer's generating facility may divert, for any purpose, DG energy that would otherwise have been metered as DG production.

(b) Arrangement and Location



The DG meter shall be located within 10 feet of the revenue meter, within line of sight and not separated by walls, gates or obstructions. Variances are not granted based on convenience or preference and must be submitted in the DG application and subsequently approved prior to construction. Meter sockets shall be accessible to Service Provider personnel at all times.

(c) Meter Socket Identification

The DG meter socket shall be labeled "Distributed Generation Meter" and shall employ signage as shown in pages 14 of this SR. Service Provider will furnish the required warning placards to the customer, for approved projects, through their distributor, Border States Electric.

(d) Meter Socket Heights

Minimum and maximum meter socket heights shall be as specified in SR-405 page 2.

(e) Equipment Protection and Grounding

Meter sockets and all related metering enclosures and equipment shall be grounded in accordance with the NEC any applicable local codes. In addition, Service Provider requires bonding at all box connectors by use of bonding bushings.

(f) Working Space



Working space requirements for all metering equipment shall be as specified in SR-405 page 10.

14. Disconnect Switches for AC Coupled Configuration

(a) General

For energy storage systems with Multimode Inverters, the utility isolation disconnect must be installed between the load side or line side Point of Interconnection and the grid-coupling device with automatic transfer switching capabilities.

Various system configurations are acceptable for utility isolation. For safety of Utility personnel, system shall automatically disconnect and isolate from Service Provider's system upon loss of utility service per UL-1741.

 	INITIATED BY	JRO	REVISION NO.	1	SR-710 Pg. 12 of 16
	ESR COMM.	12-18	ESR COMM.	3-24	
			EFFECTIVE DATE	3-24	

INTERCONNECTION REQUIREMENTS - DISTRIBUTED ENERGY STORAGE SYSTEMS, SINGLE-PHASE

14. Disconnect Switches for AC Coupled Configuration (cont'd)

As required by the DGIR, the customer shall install a Utility Isolation disconnect switch to isolate all ungrounded conductors of the DERs from the Service Provider System. The switch shall be a gang-operated, load-break device with a visible air-gap in the open position. It shall be rated for the current and voltage requirements of the DER system and shall be lockable in the open position.

The customer shall install an additional Utility DG disconnect switch to isolate all ungrounded conductors of the grid-coupling device from the Utility DG meter. The switch shall be a gang-operated, load-break device with a visible air-gap in the open position. It shall be rated for the current and voltage requirements of the DG system and shall be lockable in the open position. See page 14 for layout details.

For residential single-phase DG systems requesting load side interconnection only, the Service Provider will furnish both DG disconnect switches to the customer, if they so request.

Under no circumstances shall any disconnect switch enclosure be used as a conduit or raceway for any conductors other than the phase conductors, associated grounded conductor (neutral) and associated grounding conductor (equipment ground) of the energy storage output circuit. All phase conductors shall be terminated on appropriate terminals inside the switch enclosure.

(b) Arrangement and Location



The Utility Isolation and Utility DG disconnect switches and all required meter switches shall be located within 10 feet of the customer's revenue meter, within line of sight and not separated by walls, gates or obstructions. Variances are not granted based on convenience or preference and must be requested in the DG application and subsequently approved prior to construction. Switch installations shall be accessible and operable to Service Provider personnel at all times.

The Utility Isolation disconnect switch must be installed between the DERs and the point of interconnection.

The Utility DG disconnect switch must be installed between the Utility DG meter and the grid-coupling device.

See page 14 for layout details.

(c) Labeling



The disconnect switch shall be labeled "Utility Isolation Disconnect". The Utility DG Disconnect shall be labeled "Utility DG Disconnect". Both shall employ signage as shown in page 14 of this SR. Service Provider will furnish the required warning label through their distributor, Border States Electric.

(d) Disconnect Switch Heights

Minimum and maximum disconnect heights shall match the requirements for meter socket heights as specified in SR-405 page 2.

(e) Equipment Protection and Grounding

Disconnect switch enclosures shall be grounded in accordance with the NEC and any applicable local codes. In addition, Service Provider requires bonding at all box connectors by use of bonding bushings.

 	INITIATED BY	JRO	REVISION NO.	1	SR-710 Pg. 13 of 16
	ESR COMM.	12-18	ESR COMM.	3-24	
			EFFECTIVE DATE	3-24	

AC-COUPLED CONFIGURATION INTERCONNECTION LAYOUT SINGLE-PHASE SERVICE

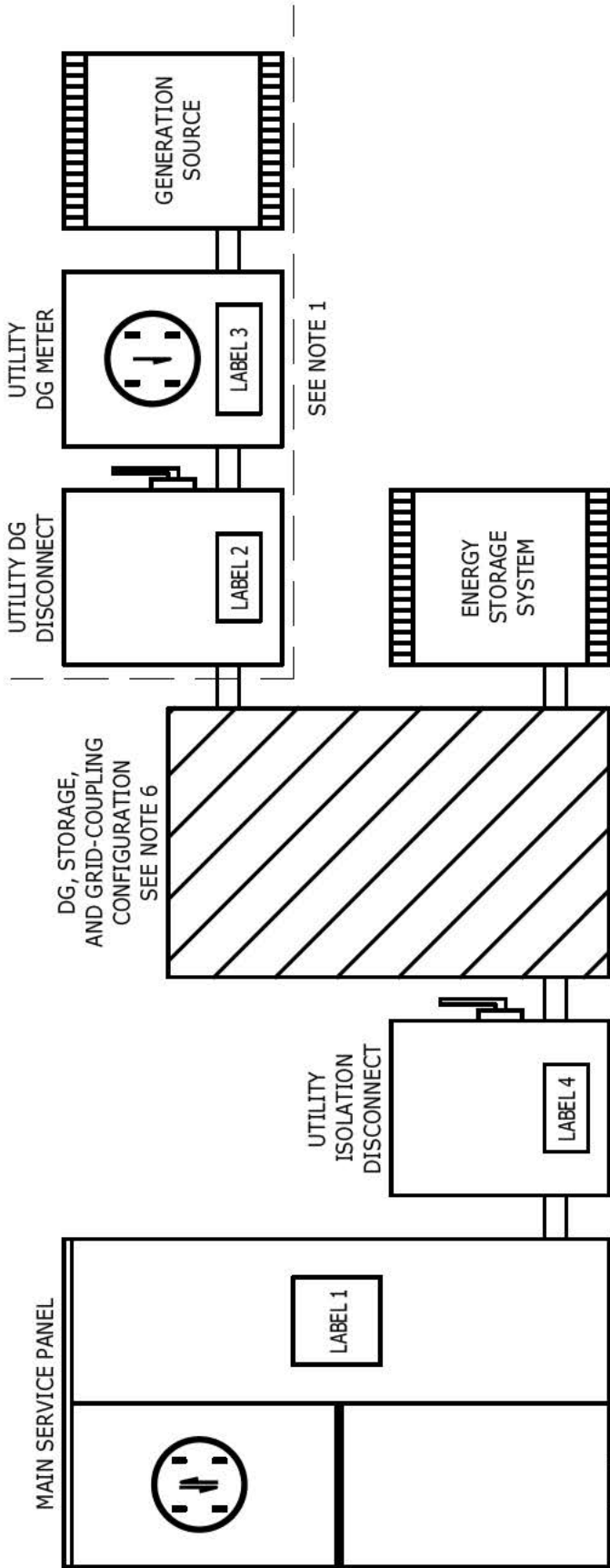

NOTES:

1. CUSTOMER IS REQUIRED TO FURNISH AND INSTALL DG DISCONNECT SWITCH, METER SOCKET (SEE SR-702), LABELS 1-4, AND RELATED DG EQUIPMENT.
2. SERVICE PROVIDER WILL PROVIDE DG DISCONNECT SWITCH, METER SOCKET AND LABELS ONLY FOR APPROVED SINGLE-PHASE RESIDENTIAL APPLICANTS.
3. REVENUE AND DG METER ARE PROVIDED BY AND INSTALLED BY SERVICE PROVIDER.
4. A GOVERNMENTAL AGENCY CLEARANCE IS REQUIRED FOR ALL DG AND ENERGY STORAGE INSTALLATIONS.
5. LABELS ARE AVAILABLE FOR PURCHASE AT BORDER STATES ELECTRIC, 763 E MacARTHUR CIRCLE, TUCSON, AZ 85714.
6. VARIOUS SYSTEM CONFIGURATIONS ARE ACCEPTABLE FOR UTILITY ISOLATION. FOR SAFETY OF UTILITY PERSONNEL, SYSTEM SHALL AUTOMATICALLY DISCONNECT/ISOLATE FROM UTILITY UPON LOSS OF UTILITY SERVICE PER UL-1741.

WARNING
ELECTRICAL SHOCK HAZARD
DISTRIBUTED GENERATION
PRESENT
TERMINALS ON LINE AND
LOAD SIDE MAY BE
ENERGIZED

LABEL 1
2-15-1912

WARNING
UTILITY DG DISCONNECT
PANEL MAY BE ENERGIZED BY
UTILITY OR CUSTOMER GENERATION

LABEL 2
2-15-1913

WARNING
DISTRIBUTED GENERATION METER
PANEL MAY BE ENERGIZED BY UTILITY
OR CUSTOMER GENERATION

LABEL 3
2-15-1911

WARNING
UTILITY ISOLATION DISCONNECT
PANEL MAY BE ENERGIZED BY
UTILITY SERVICE OR DG SOURCE

LABEL 4
2-15-1902

INTERCONNECTION REQUIREMENTS - DISTRIBUTED ENERGY STORAGE SYSTEMS, SINGLE-PHASE

15. Stand Alone Energy Storage Systems

The installation of an additional meter socket is not required if the energy storage system will be connected to a service without a DG system.

16. Disconnect Switches- Stand Alone Energy Storage Systems

(a) General

The customer shall install a Utility Isolation disconnect switch(s) to isolate all ungrounded conductors of the DERs from the Service Provider System. The switch shall be a gang-operated, load-break device with a visible air-gap in the open position. It shall be rated for the current and voltage requirements of the energy storage system and shall be lockable in the open position.

For residential single-phase energy storage systems requesting load side interconnection only, the Service Provider will furnish both Utility Isolation disconnect switch and label to the customer, if they so request.

Under no circumstances shall any disconnect switch enclosure be used as a conduit or raceway for any conductors other than the phase conductors, associated grounded conductor (neutral) and associated grounding conductor (equipment ground) of the energy storage output circuit. All phase conductors shall be terminated on appropriate terminals inside the switch enclosure.

(b) Arrangement and Location



The Utility Isolation disconnect switch and all required meter switches shall be located within 10 feet of the customer's revenue meter, within line of sight and not separated by walls, gates or obstructions. Variances are not granted based on convenience or preference and must be requested in the DG application and subsequently approved prior to construction. Switch installations shall be accessible and operable to Service Provider personnel at all times.

The Utility Isolation disconnect switch must be installed between the DERs and the point of interconnection.

See page 16 for layout details.

(c) Labeling



The disconnect switch shall be labeled "Utility Isolation Disconnect" and shall employ signage as shown in page 16 of this SR. Service Provider will furnish the required warning label through their distributor, Border States Electric.

(d) Disconnect Switch Heights

Minimum and maximum disconnect heights shall match the requirements for meter socket heights as specified in SR-405 page 2.

(e) Equipment Protection and Grounding

Disconnect switch enclosures shall be grounded in accordance with the NEC, any applicable local codes. In addition, Service Provider requires bonding at all box connectors by use of bonding bushings.

 	INITIATED BY	JRO	REVISION NO.	1	SR-710 Pg. 15 of 16
	ESR COMM.	12-18	ESR COMM.	3-24	
			EFFECTIVE DATE	3-24	

STAND-ALONE ENERGY STORAGE INTERCONNECTION LAYOUT SINGLE-PHASE SERVICE

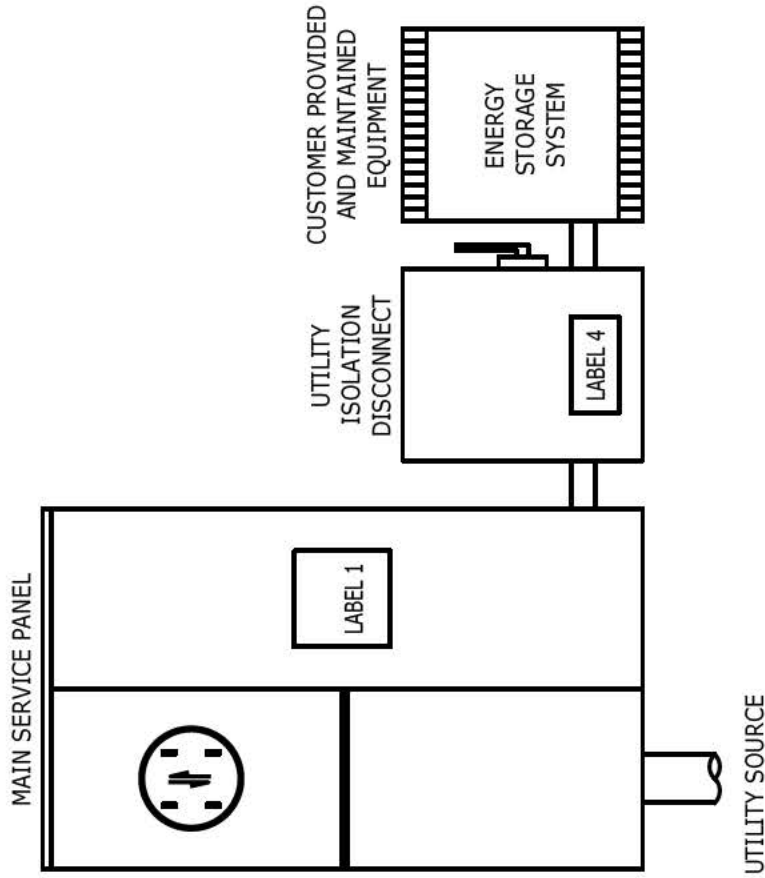

NOTES:

1. ENERGY STORAGE SYSTEM MUST ISOLATE FROM SERVICE PROVIDER'S SYSTEM DURING BACK-UP MODE.
2. SEE SR-702 PAGE 6 FOR NOTES REGARDING UTILITY ISOLATION DISCONNECT.

WARNING
ELECTRICAL SHOCK HAZARD
DISTRIBUTED GENERATION
PRESENT
TERMINALS ON LINE AND
LOAD SIDE MAY BE
ENERGIZED

LABEL 1
2-15-1912

WARNING
UTILITY ISOLATION DISCONNECT
PANEL MAY BE ENERGIZED BY
UTILITY SERVICE OR DG SOURCE

LABEL 4
2-15-1902

800 SECTION
TELECOMMUNICATION, WIRELESS AND CABLE TV
POLE ATTACHMENTS

<u>TITLE</u>	<u>SR-No.</u>
General Attachment Specification (pg. 1)	
Pole Details (pg.2)	
Anchor & Guying Details (pg. 3)	801
<u>Identification</u>	
Telecommunications and Fiber Identification	801A
 <u>Small Cell Equipment</u>	
Pole Mounted Small Cell Equipment, Attached in the Communication Space Pole Mounted Small Cell Specification (pg. 1-2)	802
Strand Mounted Small Cell Equipment, Attached in the Communication Space Strand Mounted Small Cell Specification (pg. 1-2)	803
▶ Service Entrance on Customer Owned Small Wireless Facility (SWF) or Light Pole	804
 <u>Riser Details</u>	
Riser Details, Telco/CATV	805

GENERAL ATTACHMENT SPECIFICATIONS

These General Attachment Specifications apply to any pole attachment and request by a cable television system or provider of telecommunications service to attach to a pole owned by TEP. All requests to attach to a pole owned by TEP must be submitted utilizing TEP's electronic Permit to Attach process. TEP's written approval for the specific request and a validly existing agreement is required prior to installing any attachments to a pole owned by TEP.

ATTACHMENT HEIGHT

- A. Each pole attachment is allotted one attachment height (elevation) per pole.
- B. A minimum separation of 12" (inches) is required from bolt-hole to bolt-hole between pole attachments.
- C. A minimum of 18' (feet) attachment height at the pole is required above street, road, driveway crossings or potential drivable areas.
- D. A minimum of 15'- 6" ground clearance is required at mid-span above street, road, driveway crossings or potential drivable areas.
- E. If additional height is required to maintain separation between pole attachments, attachment height, or mid_span ground clearance, then, upon TEP's prior written approval, adjustments may be made in increments of no less than 6" (inches).
- F. Standoff brackets or arm installation must maintain at least the minimum clearance from other pole attachments.

SEPARATION FROM TEP EQUIPMENT

- A. The standard separation is 13'- 6" from the pole's primary arm to the nearest pole attachment. Upon request, TEP may evaluate, but is not required to approve, accommodations for attachments on existing facilities. Minimum clearance requirements shall always apply.
- B. A minimum separation of 40" (inches), measured vertically below the lowest point of the following items to the pole attachment, is required:
 - 1. Top of riser pipe on primary, secondary, or service risers.
 - 2. Lowest point of secondary or neutral attachment.
 - 3. Street light metal frame or drip loop (measured from the bottom of the mount bracket).
- C. A minimum separation of 12" (inches) is required below bonded span guys or down guys to the pole attachment.
- D. All splice cases shall be a minimum of 5' (feet) from the pole.

HOLES

- A. A minimum separation of 6" (inches) between pole holes is required.
- B. Double-drilling holes at the same height is prohibited.
- C. Bands are prohibited on steel poles, except upon TEP's prior written approval.
- D. Eye-bolts for the slack span are required for false dead ends.
- E. Thru-bolts with an eye nut are required for attachment of aerial service wires to steel poles.

GUYING

- A. Design of adequate guying and anchoring specific for the proposed attachment is required.
- B. Reliance on existing guying to support the proposed attachment is prohibited.
- C. All guying must be installed prior to installing support messenger.
- D. Utilizing triple anchor eyes is recommended to avoid congestion of attachments.
- E. Slack spans must not place excessive loading or cause additional movement of existing facilities.

LICENSEE'S RISERS

- A. All risers must conform with TEP's Electric Service Requirement Standards (SR-805).

	INITIATED BY	DM	REVISION NO.	0	SR-801 Pg. 1 of 3
	ESR COMM.	6-18	ESR COMM.	-	
			EFFECTIVE DATE	6-18	

GENERAL ATTACHMENT SPECIFICATIONS POLE DETAILS

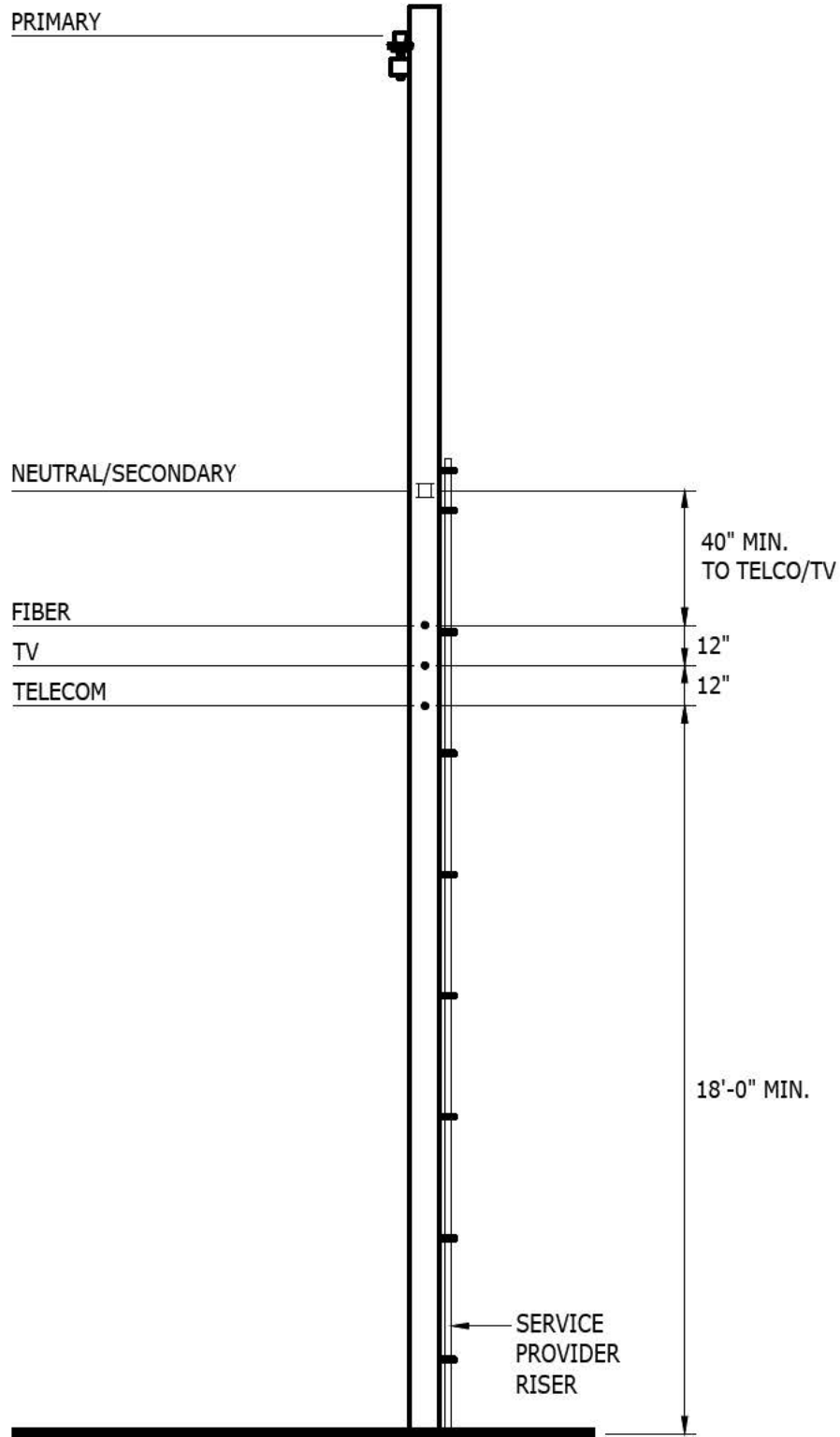

NOTE:

- FOR RISER ATTACHMENT DETAIL, SEE SR-220 & SR-805.

	INITIATED BY	MRH	REVISION NO.	0	SR-801 Pg. 2 of 3
	ESR COMM.	6-18	ESR COMM.	-	
			EFFECTIVE DATE	6-18	

GENERAL ATTACHMENT SPECIFICATIONS ANCHOR AND GUYING DETAILS

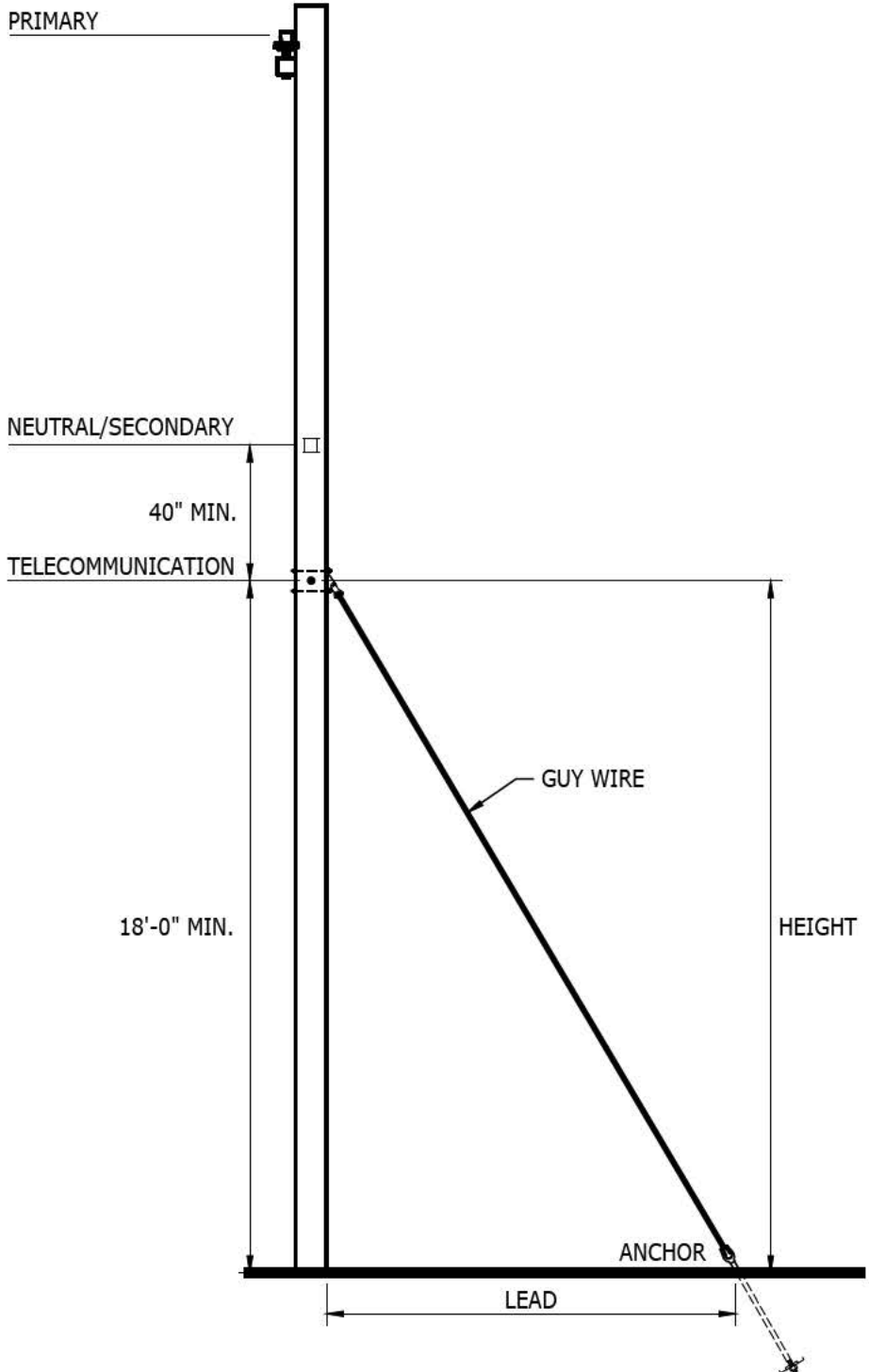

INFORMATION REQUIRED ON PERMIT TO ATTACH:

NEW ANCHOR

- LEAD LENGTH
- ATTACHMENT HEIGHT
- FEET OF PULL
- GUY WIRE SIZE
- ANCHOR SIZE (SEE NOTE#4)

EXISTING ANCHOR

- LEAD LENGTH
- ATTACHMENT HEIGHT
- FEET OF PULL
- GUY WIRE SIZE
- SIZE OF EXISTING ANCHOR
- NUMBER OF EYES
- IS THERE A VACANT EYE?

NOTES:



1. RELIANCE ON EXISTING GUYING TO SUPPORT NEW ATTACHMENTS IS PROHIBITED.
2. BREAKING STRENGTH OF GUYS CAN NOT EXCEED BREAKING STRENGTH OF AN ANCHOR.
3. ANCHORING REQUIRED AT DEADENDS, SIDE PULLS AND FALSE DEAD ENDS.
4. TEP RECOMMENDS A 3/4" (INCH) TRIPLE MINIMUM ANCHOR ON ALL NEW INSTALLATIONS.



TELECOMMUNICATIONS AND FIBER IDENTIFICATION

Licensee shall identify all attachments and overlashings as per this standard. It is the responsibility of the Licensee to install and maintain wrap-around tags to allow for easy identification of attachment owner from ground level.

1. Telecommunication and fiber attachments shall be tagged at the time of installation, during overlashings, at reconstruction of facilities including transfers and with normal maintenance.
2. Tags shall be replaced when damaged or faded.
3. Tags shall be installed at every pole.
4. Tags shall be affixed at the point of attachment.
5. Tag shall be a wrap-around marker that will be secured so as to remain permanently attached to the cable.
6. Tag shall be able to be read from the ground, or from a safe distance in the event of a downed cable or pole.
7. Tag shall be UV stable and resistant to fading from the effects of weather, chemicals, etc.
8. Tag shall be reflective for enhanced visibility in low-light conditions.
9. All tags must be generally consistent in appearance for a given attaching company throughout the Company's service area.
10. Letters shall be black or white dependent on color of wrap, which ever allows for greatest contrast and visibility from ground level.
11. Letters shall be no smaller than 3/8 inch.
12. Wrap around length shall be no smaller than 6 inches.
13. Information must be in the visible area when rolled.
14. All tags shall have the following information as a minimum;
 - Identify the telecommunication fiber/cable owner
 - Provide a 24-hour contact number

 	INITIATED BY	EKD	REVISION NO.	0	SR-801A Pg. 1 of 1
	ESR COMM.	4-20	ESR COMM.	-	
			EFFECTIVE DATE	-	



POLE MOUNTED SMALL CELL EQUIPMENT ATTACHED IN THE COMMUNICATION SPACE



These specifications apply to any pole attachment and request by a cable television system or provider of telecommunications service ("Licensee") to attach to a distribution pole ("Pole") owned by TEP for pole mounted small cell antennas and risers attached in the communication space ("Pole Mounted Small Cell Equipment"). All requests to attach to a pole owned by TEP must be submitted utilizing TEP's electronic Permit to Attach process. TEP's written approval for the specific request and a validly existing agreement is required prior to installing any attachments to a pole owned by TEP.

GENERAL REQUIREMENTS

- A. In addition to these specifications, all Pole Mounted Small Cell Equipment must meet TEP's Pole Attachment Guidelines, General Attachment Specifications, Standards, and any other applicable industry and/or governing standards. In the event of a conflict between these specifications and any other specification or standard, TEP may apply the more stringent requirement.
- B. Attachments for Pole Mounted Small Cell Equipment other than antennas and risers is prohibited.
- C. Attachment requests are evaluated to ensure safety, reliability, and proper engineering on TEP's Poles and electric system. All attachments must meet TEP Standards, including but not limited to SR-805 and SR-220 (when there are existing risers on the Pole). Refer to TEP's Pole Attachment Guidelines (available at TEP.com) for the requirements necessary to process Attachment requests.
- D. Pole Mounted Small Cell Equipment is prohibited on a Pole that is located in a walk-in easement or where there is no bucket truck access.
- E. Pole Mounted Small Cell antennas must be installed on the face of the pole. Upon request, TEP may evaluate, but is not required to approve, installation on the quadrant of the pole.
- F. No more than three (3) Pole Mounted Small Cell sector antennas may be installed on any one pole.
- G. Pole Mounted Small Cell antennas are limited to a maximum vertical profile of 30 inches and a maximum of 6 cubic feet in volume.
- H. Customer installed ground equipment must meet all applicable TEP Electric Service Requirements.
- I. Pole Mounted Small Cell Equipment is prohibited on or near poles with reclosers, regulators, capacitors, switches, or other TEP equipment that are radio controlled.
- J. Color schemes for all Pole Mounted Small Cell Equipment are limited to grey or black. All Pole Mounted Small Cell Equipment must blend in with the existing cables to the greatest extent practicable.
- K. RF warning labels must be attached to all Pole Mounted Small Cell Equipment - consistent with all applicable OSHA requirements - and on the pole where the equipment is attached.
- K. Licensee is solely responsible for radio frequency ("RF") radiation emitted by Licensee's equipment. Licensee is responsible for ensuring RF radiation from its small cell antenna(s) is within the limits allowable under all Federal Law and Regulations.
- L. The phone number for the communications Network Operations Center (NOC) must be prominently labeled on the Pole Mounted Small Cell Equipment and on the Pole where the equipment is attached.
- M. TEP reserves the right to disconnect power, at the source, to the small cell antenna(s) in the event of an emergency or for TEP system maintenance.

	INITIATED BY	DM	REVISION NO.	1	SR-802  Pg. 1 of 2
	ESR COMM.	6-18	ESR COMM.	5-21	
			EFFECTIVE DATE	5-21	

POLE MOUNTED SMALL CELL SPECIFICATION

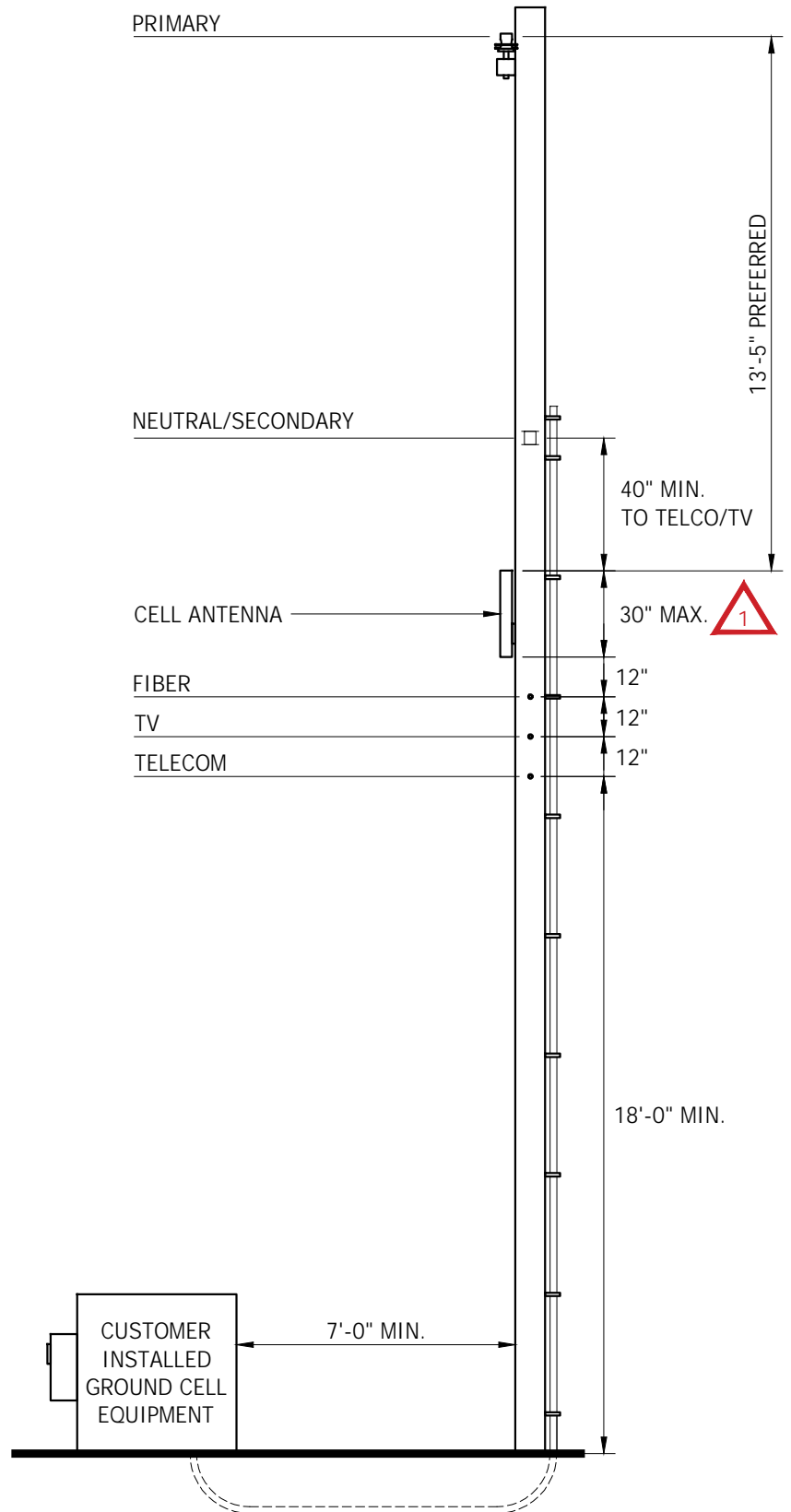

NOTES:

1. FOR RISER ATTACHMENT DETAIL, SEE SR-220 & SR-805.
2. FOR APPROVED METER & SERVICE EQUIPMENT, SEE SR-452.
3. MAXIMUM ANTENNA HEIGHT SHALL NOT EXCEED 30 INCHES. △ 1
4. ANTENNA SHALL ONLY BE INSTALLED ON POLES THAT ARE BUCKET TRUCK ACCESSIBLE.
5. PAD-MOUNTED EQUIPMENT PLACEMENT SHALL BE NO LESS THAN 7 FEET FROM THE BASE OF POLE.



	INITIATED BY	MRH	REVISION NO.	1	SR-802 Pg. 2 of 2
	ESR COMM.	6-18	ESR COMM.	5-21	
			EFFECTIVE DATE	5-21	

STRAND MOUNTED SMALL CELL EQUIPMENT ATTACHED IN THE COMMUNICATION SPACE

These specifications apply to any pole attachment and request by a cable television system or provider of telecommunications service to attach to a pole owned by TEP for strand mounted small cell equipment attached in the communication space ("Strand Mounted Equipment"). All requests to attach to a pole owned by TEP must be submitted utilizing TEP's electronic Permit to Attach process. TEP's written approval for the specific request and a validly existing agreement is required prior to installing any attachments to a pole owned by TEP.

GENERAL REQUIREMENTS

- A. In addition to these specifications, all Strand Mounted Equipment must meet TEP's General Attachment Specifications, TEP standards, and any other applicable industry and/or governing standards. In the event of a conflict between these specifications and any other specification or standard, TEP may apply the more stringent requirement.
- B. Panel-type antennas are limited to no more than two (2) antennas and two (2) radios on one side of a pole with its ancillary equipment, such as a router and power conversion unit, on the other side of the pole for weight distribution purposes. If a single panel antenna and a single radio are used, then all of the equipment including any ancillary equipment, such as the router and power conversion equipment, may be mounted on one side of the pole.
- C. Omni-type antennas are limited to no more than two (2) Omnis attached to a single radio on the same bracket and no more than two (2) radios with their associated Omnis and supporting ancillary hardware, such as a router and power conversion unit, may be mounted on one side of a pole. If a single radio is attached with its two (2) Omni antennas mounted on the same bracket, then all of the equipment including any ancillary equipment, such as the router and power conversion equipment, may be mounted on one side of the pole.
- D. "Mixed use" installations may consist of: (1) a single radio with Omni-type antennas on the same bracket and an associated ancillary router mounted on one side of the pole; and (2) a single panel antenna with a single radio including any ancillary equipment mounted on the other side of the pole.
- E. Strand Mounted Equipment is prohibited on or near poles with reclosers, regulators, capacitors, switches, or other TEP equipment that may be affected by radio control.
- F. Color schemes for all Strand Mounted Equipment are limited to grey or black. All Strand Mounted Equipment must blend in with the existing cables to the greatest extent practicable.
- G. RF warning labels must be attached to all Strand Mounted Equipment - consistent with all applicable OSHA requirements - and on the closest pole.
- H. The phone number for the communications Network Operations Center (NOC) must be prominently labeled on the Strand Mounted Equipment.
- I. All Strand Mounted Equipment shall be a minimum of 5' (feet) from the pole.
- J. All Strand Mounted Equipment is limited to a maximum vertical profile of 12" (inch) and a maximum horizontal profile of 24" (inch).
- K. Separation of all Strand Mounted Equipment from other pole attachments shall be a minimum of 4" (inch) anywhere in the span.
- L. TEP may require 12" (inch) standoff brackets to offset Strand Mounted Equipment from other pole attachments, as determined by engineering survey.



INITIATED BY	DM	REVISION NO.	0	SR-803 Pg. 1 of 2	
	ESR COMM.	6-18	ESR COMM.		-
			EFFECTIVE DATE		6-18

STRAND MOUNTED SMALL CELL SPECIFICATION

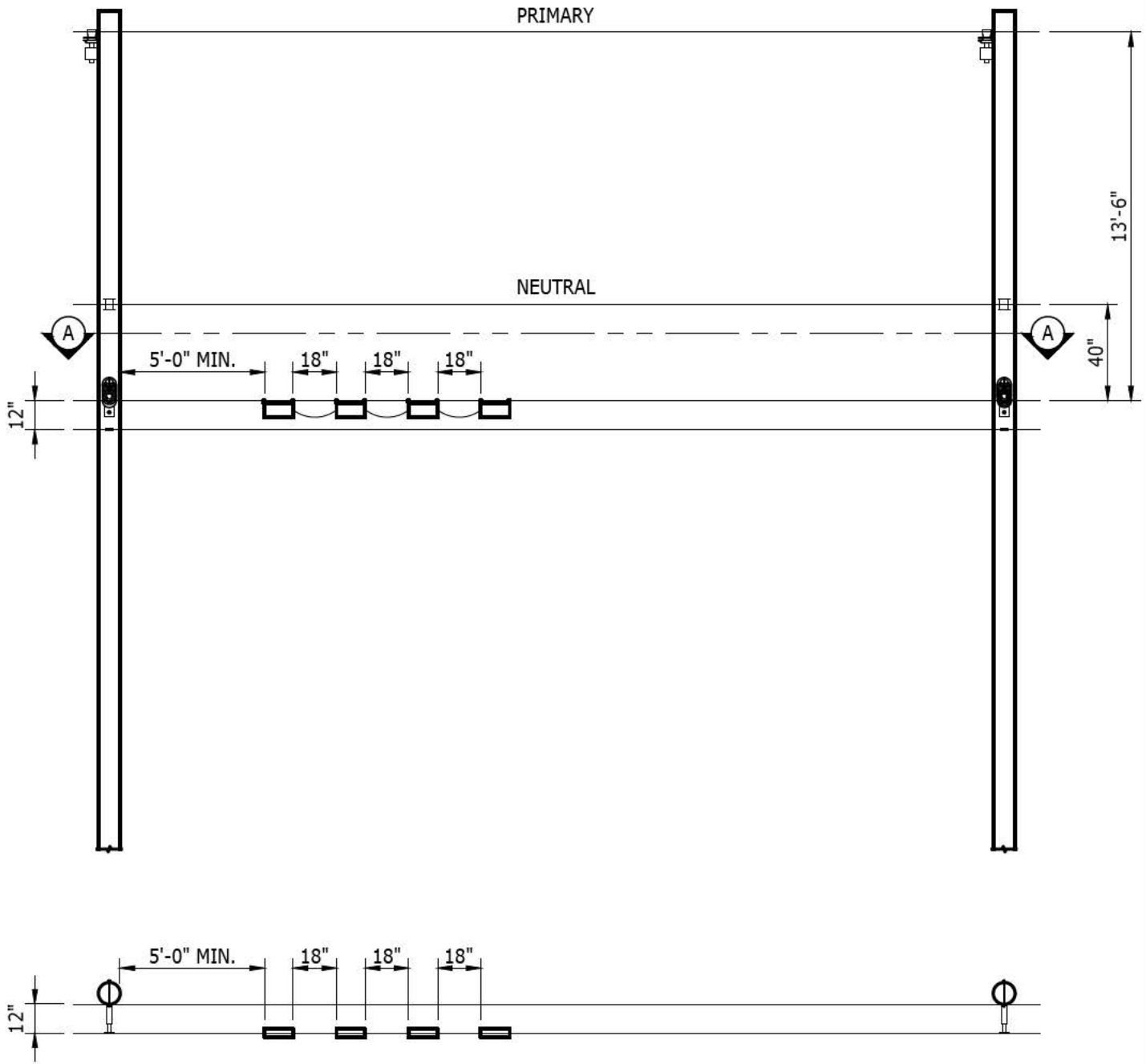

SECTION A-A

NOTES:

1. TWELVE (12) INCH STANDOFF BRACKET(S) MAY BE REQUIRED.
2. EQUIPMENT SHALL BE A MINIMUM OF 5 FEET FROM POLE.
3. RF WARNING LABELS SHALL BE ATTACHED TO SMALL CELL ANTENNAS AND THE CLOSEST POLE.



	INITIATED BY	MRH	REVISION NO.	0	SR-803 Pg. 2 of 2
	ESR COMM.	6-18	ESR COMM.	-	
			EFFECTIVE DATE	6-18	

USE: Installation option for metering equipment on customer owned poles.

SERVICE ENTRANCE ON CUSTOMER OWNED SMALL WIRELESS FACILITY (SWF) OR LIGHT POLE



These requirements apply to any request by a cable television system or provider of telecommunication service to co-locate metering equipment on a customer owned SWF or governing agency owned street light pole. All requests to attach metering equipment to a customer owned pole must be submitted by utilizing TEP's Service Application process. Approval from Company Design Services is required prior to installation of any such facility.



GENERAL NOTES:

1. Attachment of metering equipment to any pole where Service Provider owned area lighting and/or electric distribution or transmission wires are attached, is not allowed.
2. Location of pole and side of pole where service entrance is to be attached, shall be mutually agreed upon between the Customer and Design Services.
3. Designated Point of Service per this standard will be the the customer installed sub-grade pedestal.
4. Service entrance panel shall be mounted on the customer owned pole parallel to the sidewalk or roadway to prevent interference with pedestrian traffic. Installation shall be on the pole side opposite on-coming traffic to support safety of Company employees during installation and maintenance of the meter.
5. Metered and un-metered wires shall be separated by a suitable barrier and shall not pass through the same section(s) of the service entrance. Barrier(s) shall be metallic, 16 gauge minimum.
6. Protective meter cover will be required, at customer's expense, if Service Provider determines that excessive vandalism occurs to meter. Notification will be provided and 30 days allowed for installation of a protective meter cover.
7. Do not trench under Company owned pad-mount equipment without Service Provider personnel present. Service Provider's access crew can be scheduled to assist with conduit placement and/or if trenching is required under company owned equipment. Arrangements must be made by calling 520-918-8300 (TEP) or 520-761-7951 (UES), a minimum of five working days in advance.
8. Other utilities are not permitted to pass underneath any Company equipment.
9. Refer to SR-108 for Right-of-Way and Easement requirements.

CUSTOMER RESPONSIBILITIES:

10. Ensure pole is engineered to support weight and allow for solid attachment of metering equipment. Pole shall comply with applicable wind/seismic code requirements as required by the Authority Having Jurisdiction (AHJ).
11. Purchase, install and maintain meter socket per the Company SR-400 Series standards. Ringless sockets are not acceptable. All meter sockets shall be mounted between 3'-6" minimum and 6'-3" maximum from final grade to the center of the meter.
12. Provide a 17" x 30" (H-20 Rated Junction Box) sub-grade pedestal, refer to SR-308, FIGURE 1, for approved manufacturers.
13. Provide a service disconnecting device which meets all requirements of the current National Electric Code (NEC). The operation of the device shall be such that the neutral (grounded conductor) is not broken when the device is opened. The operating handle or member shall be capable of being sealed either open or closed.



 Tucson Electric Power		INITIATED BY	EKD	REVISION NO.	1	SR-804 Pg. 1 of 3
		ESR COMM.	6-21	ESR COMM.	3-22	
				EFFECTIVE DATE	3-22	

USE: Installation option for metering equipment on customer owned poles.

SERVICE ENTRANCE ON CUSTOMER OWNED SMALL WIRELESS FACILITY (SWF) OR LIGHT POLE



CUSTOMER RESPONSIBILITIES (continued):

14. The service disconnect shall be effectively grounded in compliance with the National Electrical Code (NEC) and applicable requirements of local governmental codes (AHJ).
15. A test-bypass block with rigid insulation barriers shall be furnished, installed and wired or bussed to the meter socket by the manufacturer. Connection sequence is LINE-LOAD from left to right. Each line and load position shall be clearly identified by 3/4 inch minimum block letter labeling. Test-bypass cover panels shall be sealable and fitted with a lifting handle. All panels exceeding 16 inches in width shall require two lifting handles.
16. Communication riser(s), on Service Provider pole, shall be installed in compliance with SR-805.
17. Provide and install a continuous 2 1/2 inch conduit run from Service Provider pad-mount transformer, pedestal or pole to sub-grade pedestal (Point of Service). Trench depth to be 36 inches. Conduit sweeps into existing equipment shall be 2.5" x 36" x 90 degree, grey PVC Electrical Grade, Schedule 40. The total of all deflections shall not exceed 360 degrees in any continuous duct run between outlets. Refer to SR-205 (duct/concrete and mandrel pull), SR-207 (bedding and backfill), SR-209 (trenching and conduit) and SR-220 (riser).
18. The customer is to provide and install the service cable under the supervision of a Company Access Crew. An outage may be required. The conductor size shall have a range of #6 - 350kcmil, in order to connect to the Company supplied connectors at the Point-of-Service. The neutral conductor is to be identified with white tape at both ends for 3 inches in length. An address tag (Dymo aluminum embossing tape or similar) shall be attached to the neutral conductor at the Point-of-Service. The customer owned service cable shall be in compliance with the National Electrical Code (NEC) and applicable requirements of local governmental codes (AHJ).



SERVICE PROVIDER RESPONSIBILITIES:

-  19. Specify location for sub-grade pedestal, which will be considered the Point of Service. Location of pedestal will be a minimum of 7 feet and maximum of 12 feet from the customer owned pole, in a non-traffic area.
20. If service is provided from a pole, provide and install continuation of duct on Company owned pole and ground the metal riser.
21. Provide, install and maintain service conductor from Company pad-mount transformer, pedestal or pole to a customer installed sub-grade pedestal (Point of Service). Upon connection to the Company's distribution system, the sub-grade pedestal will be maintained by the Service Provider.
22. Provide, install and maintain meter.
23. Design Services will document in Company mapping system that conductor from Point of Service to the Service Entrance is customer owned.

APPROVED METERING EQUIPMENT:

- Milbank, Cat. No. CP2B11C1XGPTEP1
- Milbank, Cat. No. CP2B11C1XGPTEP3



 Tucson Electric Power	 UniSource Energy SERVICES SANTA CRUZ COUNTY	INITIATED BY	EKD	REVISION NO.	1	SR-804 Pg. 2 of 3
		ESR COMM.	6-21	ESR COMM.	3-22	
		ESR COMM.		EFFECTIVE DATE	3-22	

USE: Installation option for metering equipment on customer owned poles.

SERVICE ENTRANCE ON CUSTOMER OWNED SMALL WIRELESS FACILITY (SWF) OR LIGHT POLE

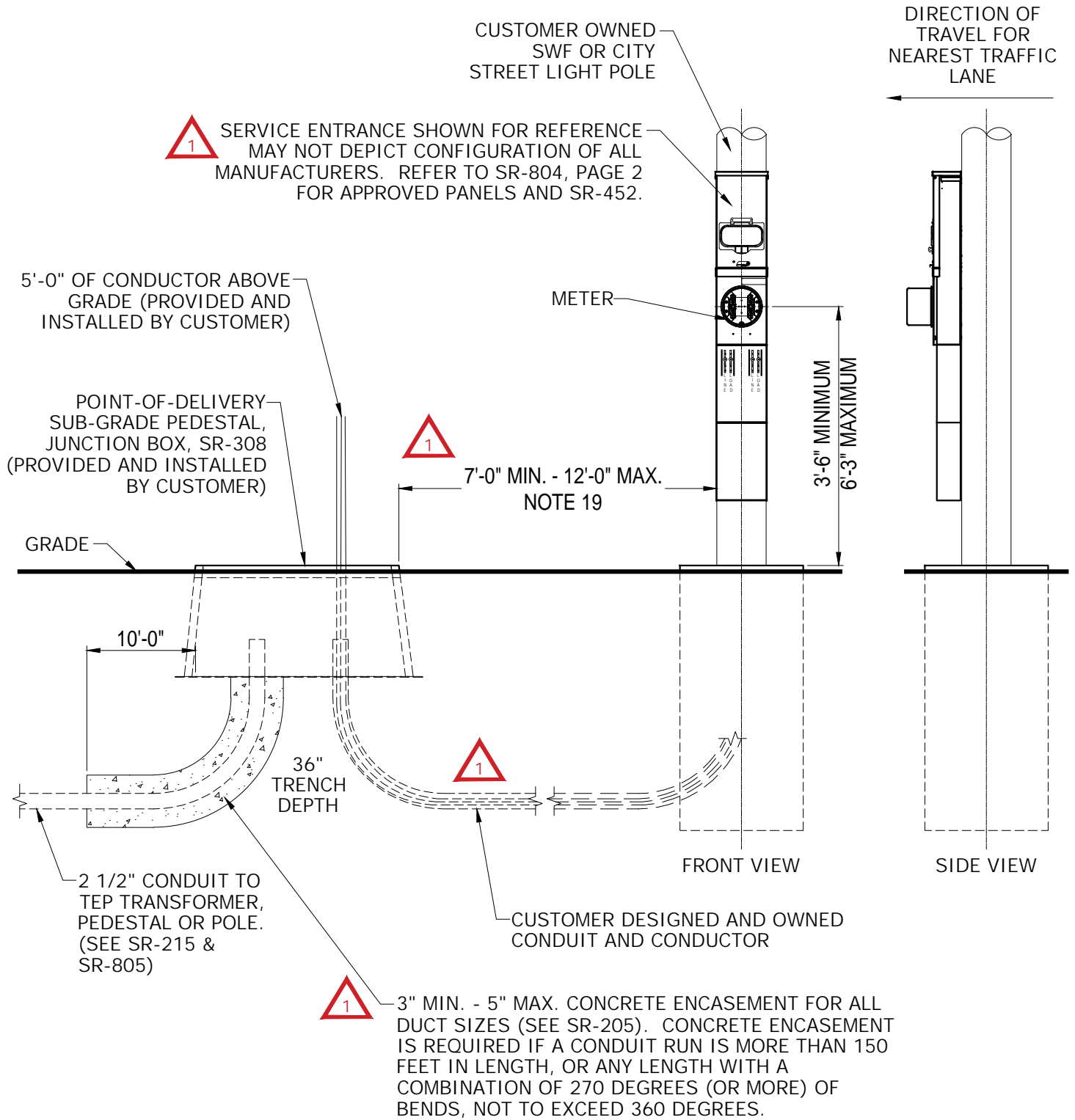

<p>Tucson Electric Power</p>	<p>SANTA CRUZ COUNTY</p>	INITIATED BY	EKD	REVISION NO.	1	SR-804 Pg. 3 of 3
		ESR COMM.	6-21	ESR COMM.	3-22	
				EFFECTIVE DATE	3-22	

RISER DETAILS - TELCO/CATV

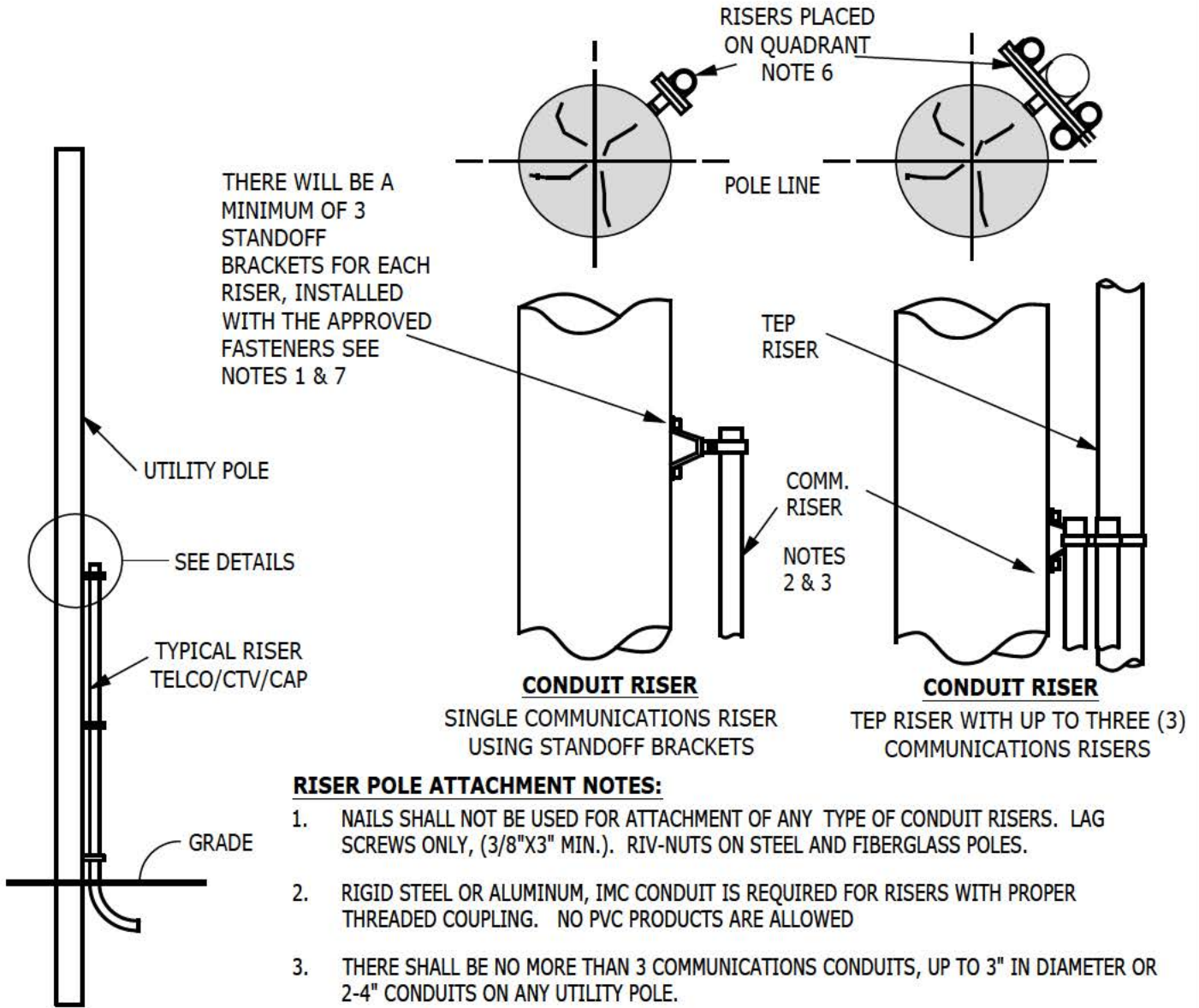

**RISER
INSTALLATION** SEE
DETAILS

APPROVED CONDUIT
BRACKETS CATALOG NUMBERS

- 2" 4-CSO-7/stk-2T
- 2.5" 4-CSO-7/stk-2.5K
- 4" 4-CSO-7/stk-4
- 6" 4-CSO-7stk-6

RISER POLE ATTACHMENT NOTES:

1. NAILS SHALL NOT BE USED FOR ATTACHMENT OF ANY TYPE OF CONDUIT RISERS. LAG SCREWS ONLY, (3/8"X3" MIN.). RIV-NUTS ON STEEL AND FIBERGLASS POLES.
2. RIGID STEEL OR ALUMINUM, IMC CONDUIT IS REQUIRED FOR RISERS WITH PROPER THREADED COUPLING. NO PVC PRODUCTS ARE ALLOWED
3. THERE SHALL BE NO MORE THAN 3 COMMUNICATIONS CONDUITS, UP TO 3" IN DIAMETER OR 2-4" CONDUITS ON ANY UTILITY POLE.
4. IF THERE IS A PRIMARY OR SECONDARY TEP RISER ON A POLE, IT SHALL NOT BE RE-POSITIONED WITHOUT TEP AUTHORITY. CONTACT DESIGN FOR CONSTRUCTION REQUIREMENTS. COMMUNICATIONS RISERS SHALL BE CLUSTERED (SEE DETAILS ABOVE) IN THE SAME QUADRANT AS THE UTILITY RISER.
5. IF THERE IS NO TEP RISER ON THE POLE, THE COMMUNICATIONS RISER SHALL BE ON THE OPPOSITE SIDE OF POLE FROM ON-COMING TRAFFIC.
6. STANDOFF BRACKETS SHALL HOLD CONDUIT 4" OFF OF WOOD POLES. ALUMA-FORM MANUFACTURES UNITS USED BY TUCSON ELECTRIC POWER CO., SEE APPROVED CAT. NUMBERS.
7. SEE SR-220, PG. 2 OF 2 FOR PROPER RISER INSTALLATION.
8. FOR POLES CONTAINING INTERNAL CABLES, RISERS OR FIBER, ONLY EXTERNAL BANDING METHODS MAY BE USED. FOR QUESTIONS ABOUT POLES WITH INTERNAL CABLES, OR TO ENSURE SUCH POLES ARE PROPERLY IDENTIFIED PER TEP SPEC EM-S31, PLEASE CONTACT TEP TELECOMMUNICATION PROJECT MANAGER AT 918-8360.

FORMERLY SR-221, SECTION 200

900 SECTION CLEARANCES

TITLE

SR-No.

Design Principles for Overhead Distribution Lines Near Public Facilities

SR-901

Electrical Clearance Considerations

SR-902

Service Entrance Clearance from Gas Meter Regulator or Extension Vent

SR-910

USE: OVERHEAD DISTRIBUTION LINES WITH VOLTAGE LESS THAN 20.8kV

DESIGN PRINCIPLES FOR OVERHEAD DISTRIBUTION LINES NEAR PUBLIC FACILITIES

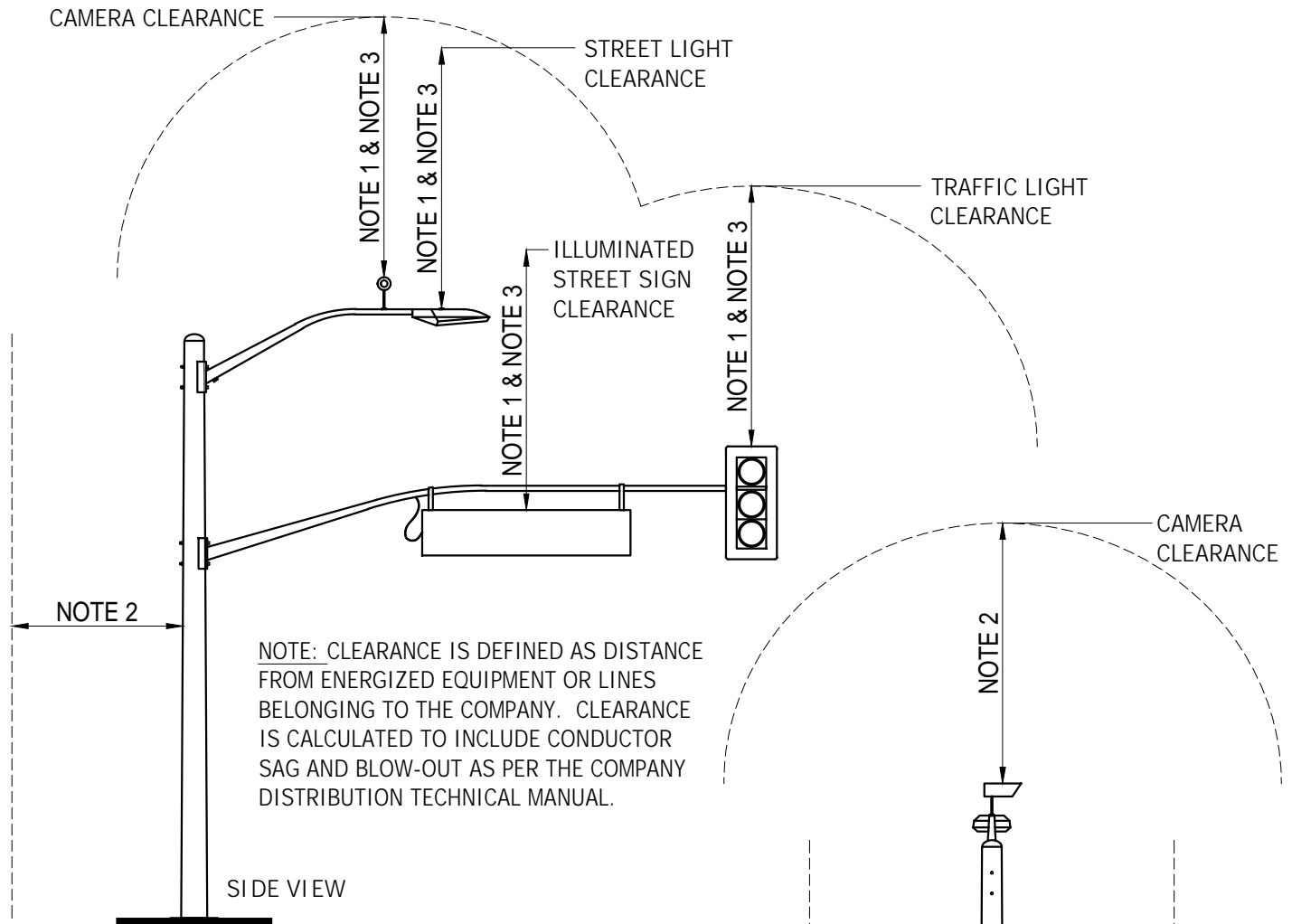

NOTE: CLEARANCE IS DEFINED AS DISTANCE FROM ENERGIZED EQUIPMENT OR LINES BELONGING TO THE COMPANY. CLEARANCE IS CALCULATED TO INCLUDE CONDUCTOR SAG AND BLOW-OUT AS PER THE COMPANY DISTRIBUTION TECHNICAL MANUAL.

SIDE VIEW

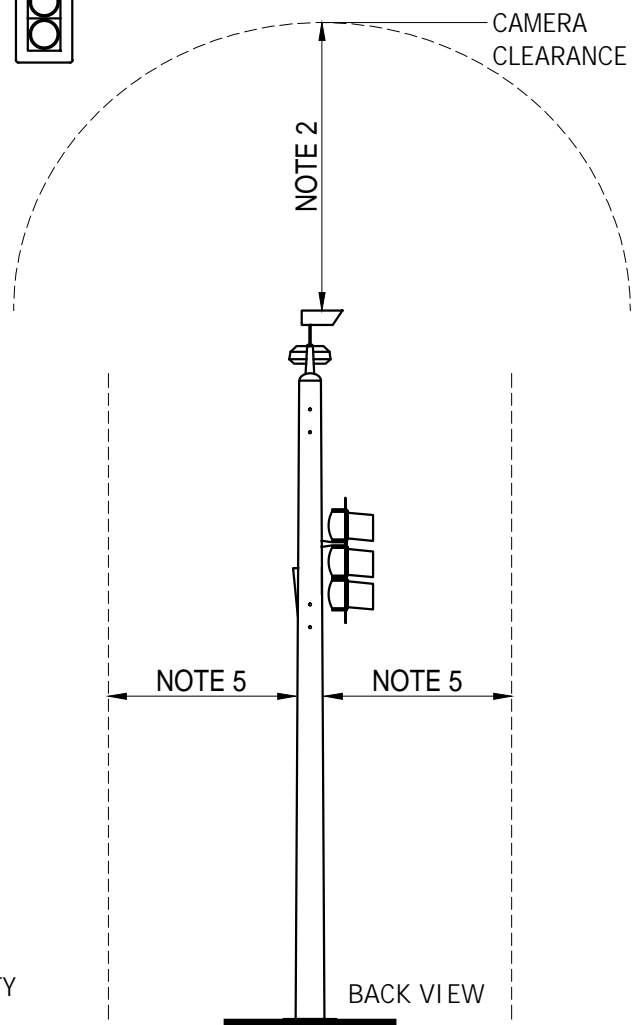

BACK VIEW

OSHA AND NESC CODE REFERENCE:

NATIONAL ELECTRIC SAFETY CODE (NESC) REQUIRES VERITICAL CLEARANCE OF 4'-6" AND HORIZONTAL CLEARANCE OF 5'-0" FOR DISTRIBUTION VOLTAGES UP TO 20.8kV. THESE MINIMUM CLEARANCES WILL BE MAINTAINED AT ALL TIMES. VOLTAGES ON THE COMPANY SYSTEM GREATER THAN 20.8kV REQUIRE ADDITIONAL CLEARANCE AND ARE NOT ADDRESS IN THIS STANDARD. IF EXPECTED ACTIVITY UNDER A LINE REQUIRES GREATER CLEARANCE THE TALLEST OBJECT THAT MIGHT PASS UNDER THE LINE WILL BE TAKEN INTO ACCOUNT.

OCCUPATIONAL SAFETY AND HEALTH ADMINISTRATION (OSHA) REQUIRES A MINIMUM CLEARANCE OF 10'-0" FOR NON-UTILITY PERSONNEL AND THEIR EQUIPMENT WORKING IN CLOSE PROXIMITY TO ELECTRIC POWER LINES ENERGIZED UP TO 50kV, OSHA RULE: 1910.333 (C)(3)(I).

 Tucson Electric Power	 SANTA CRUZ COUNTY	INITIATED BY	EKD	REVISION NO.	0	SR-901 Pg. 1 of 2
		ESR COMM.	8-20	ESR COMM.	-	
				EFFECTIVE DATE	-	

USE: OVERHEAD DISTRIBUTION LINES WITH VOLTAGE LESS THAN 20.8kV

DESIGN PRINCIPLES FOR OVERHEAD DISTRIBUTION LINES NEAR PUBLIC FACILITIES

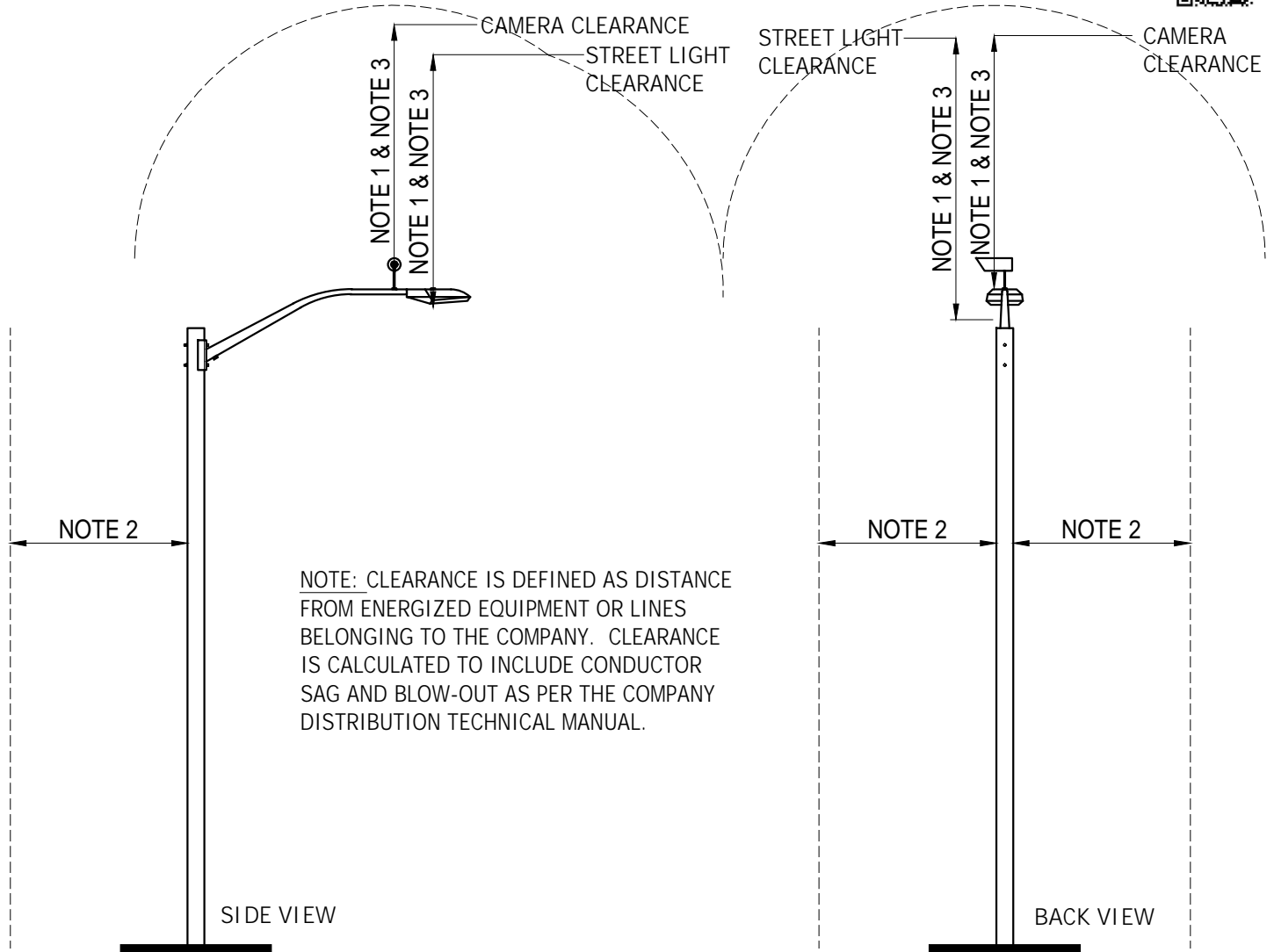

NOTES:

1. NEW COMPANY OVERHEAD LINES BUILT NEAR PUBLIC FACILITIES REQUIRING PERIODIC MAINTENANCE, SUCH AS TRAFFIC CAMERAS, TRAFFIC SIGNALS, STREET LIGHT HEADS AND ILLUMINATED STREET SIGNS WILL BE DESIGNED TO TRY TO AVOID, OR MINIMIZE CONFLICT FOR MAINTENANCE BY USING 10'-0" OF CLEARANCE.
2. NEW COMPANY OVERHEAD LINES BUILT NEAR PUBLIC FACILITIES NOT REQUIRING PERIODIC MAINTENANCE, SUCH AS STREET AND TRAFFIC LIGHT POLES, SUPPORT ARMS, ETC. WILL BE DESIGNED TO MINIMIZE CONFLICT BY USING 6'-6" FOR CLEARANCE.
3. WHERE PROVIDING A MINIMUM OF 10'-0" OF CLEARANCE FROM ENERGIZED CONDUCTORS TO PUBLIC FACILITIES REQUIRING PERIODIC MAINTENANCE CREATES OPERATIONAL DIFFICULTIES FOR THE COMPANY, THE COMPANY POLICY IS TO REDUCE THE MINIMUM CLEARANCE TO ANY FIXED STRUCTURE OR EQUIPMENT TO 6'-6" AT THE CLOSEST APPROACH. A MINIMUM OF 4'-6" TO ANY FIXED STRUCTURE OR EQUIPMENT, NOT OWNED BY THE COMPANY, WILL BE MAINTAINED FOR ALL INSTALLATIONS.
4. TO MINIMIZE CONFLICT DUE TO CONDUCTOR SAG AND BLOW-OUT PUBLIC FACILITIES SHOULD BE DESIGNED TO BE INSTALLED WITHIN CLOSE PROXIMITY TO COMPANY STRUCTURES. MINIMUM CLEARANCE SEPERATION MUST BE MAINTAINED AND CLEARANCE CALCULATIONS WILL BE PERFORMED ON EACH INDIVIDUAL LOCATION DUE TO NUMEROUS VARIABLES OF OVERHEAD LINE CONSTRUCTION.
5. EXISTING COMPANY OVERHEAD FACILITIES WILL BE REVIEWED FOR RELOCATION, DUE TO ROAD IMPROVEMENT PROJECTS, BASED ON A MINIMUM CLEARANCE OF 4'-6" TO ANY NEW PUBLIC FACILITY, UPON COMPLETION OF INSTALLATION.
6. WHEN WORKING NEAR COMPANY OVERHEAD LINES AND EQUIPMENT, MINIMUM APPROACH DISTANCES MUST BE MAINTAINED TO PROTECT THE WORKER AND COMPANY EQUIPMENT. REFER TO THE COMPANY OVERHEAD PROTECTION POLICY AT WWW.TEP.COM/OVERHEAD-EXCAVATION/#OVERHEAD .

 Tucson Electric Power	 SANTA CRUZ COUNTY	INITIATED BY	EKD	REVISION NO.	0	SR-901 Pg. 2 of 2
		ESR COMM.	8-20	ESR COMM.	-	
				EFFECTIVE DATE	-	

USE: Assist customer when designing project to help maintain safe clearance from electrical facilities.

ELECTRICAL CLEARANCE CONSIDERATIONS



The Company utilizes the National Electrical Safety Code (NESC) when designing the placement of electrical facilities. The code considers the closest approach of the conductors under all operating conditions, this includes conductor movement due to wind, the sag of the conductor, temperatures and mechanical operation of other devices. The code also considers activities occurring in or around electrical facilities when establishing required clearances. For example, if oversized vehicles might pass under electrical lines, the code provides clearance that take the size of the vehicle into account.



The Company requires engineers and Customers to use OSHA requirements when designing or updating projects that are near the Company's electrical facilities. OSHA requires a minimum clearance of 10 feet for non-utility personnel and their equipment working in close proximity to electric power lines energized up to 50kV (OSHA rule: 1910.333(c)(3)(i)). The Company also requires that any non-utility personnel contact the Company for overhead protection for overhead lines and have all underground lines bluestaked prior to commencing work.

When planning projects, Customers should adequately prepare for construction activities that will bring personnel and their equipment within close proximity of Company facilities, in order to maintain the 10 foot OSHA clearance. This is especially important to consider when building multi-story projects near overhead lines. Overhead protection must be called and scheduled before beginning any work near the Company facilities. Customers shall contact a Design Services representative during the planning phase to help with clearance considerations.

There may be times when the proper OSHA and NESC clearances can not be maintained due to new or updated construction. Under those circumstances, the Company, at its discretion, may relocate the company owned facilities at the Customer's expense. There are many factors involved in this relocation, including easements, required outages, permitting, etc. that will need to be determined before the Company can consider relocating the facilities.

Disclaimer: The recommendations and statements provided above are for informational purposes only and do not constitute a binding agreement, obligation, or legal responsibility on the part of the Company. Nothing in this document shall be construed as creating a contract, warranty, or guarantee of any kind. Furthermore, the requirements described here are not intended to and do not alter any safety obligations imposed under applicable law, including but not limited to OSHA and the High Voltage Power Lines and Safety Restrictions Act (A.R.S. 40-360.41, et seq. All non-utility personnel operating near electrical facilities are responsible for researching and establishing safety requirements for the work they are performing.

Note: For more information about overhead and excavation, go to <https://www.tep.com/overhead-excavation/>.

		INITIATED BY	JAB	REVISION NO.	0	SR-902 Pg. 1 of 1
		ESR COMM.	5-25	ESR COMM.	-	
				EFFECTIVE DATE	5-25	

SERVICE ENTRANCE CLEARANCE FROM GAS METER REGULATOR OR EXTENSION VENT



ELECTRIC SERVICE ENTRANCE

ELECTRIC SERVICE ENTRANCE

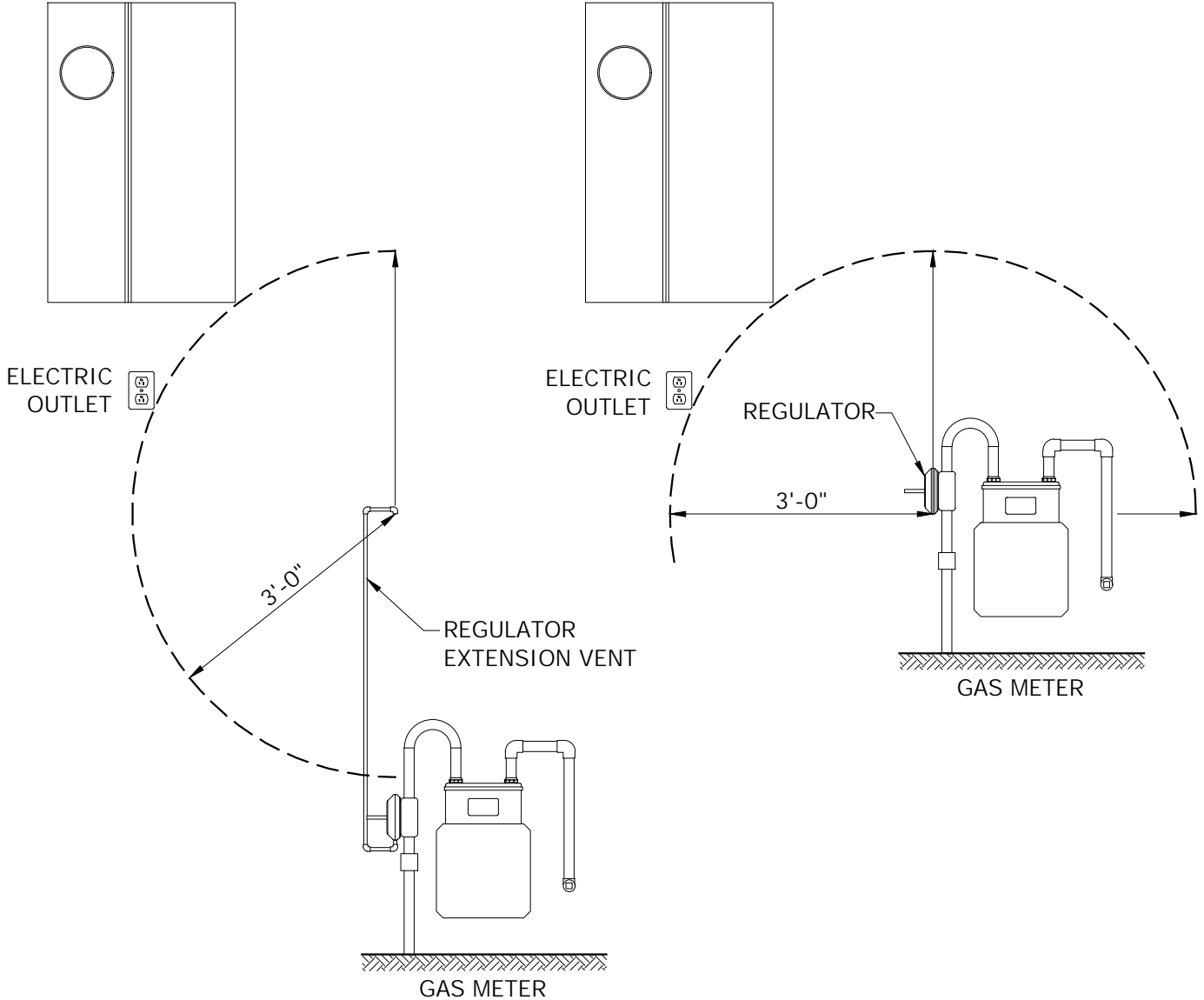

NOTES:













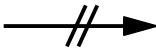

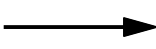



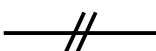









1. INFORMATION IN THIS STANDARD IS PROVIDED TO PROMOTE AWARENESS OF LOCAL GAS COMPANY CLEARANCE REQUIREMENTS.
2. A NEW ELECTRIC SERVICE ENTRANCE SHALL BE INSTALLED TO PROVIDE A MINIMUM OF 3 FEET CLEARANCE TO GAS METER REGULATOR OR REGULATOR EXTENSION VENT. IF SERVICE ENTRANCE IS BEING RELOCATED CUSTOMER SHOULD CONTACT THE LOCAL GAS COMPANY FOR JOB SPECIFIC CLEARANCE REQUIREMENTS.

		INITIATED BY	EKD	REVISION NO.	0	SR-910 Pg. 1 of 1
		ESR COMM.	6-23	ESR COMM.	-	
				EFFECTIVE DATE	6-23	

DRAWING LEGEND











<u>TITLE</u>	<u>PAGE No.</u>
Overhead (O.H.)	1
Underground (U.G.), Single Phase	2
Underground (U.G.), Three Phase	3
▶ Customer Technologies	3

LEGEND OVERHEAD

	TEP POLE NON-JOINT USE		PRIMARY METERING
	TEP POLE JOINT USE		SERVICE 2 WIRE
	TELCO POLE JOINT USE		SERVICE 3 WIRE
	POLE REMOVAL		SERVICE 4 WIRE
	STEEL STRUCTURE		SECONDARY 2 WIRE
	THIRD PARTY OWNED POLE		SECONDARY 3 WIRE
	SINGLE PHASE TRANSFORMER (PROPOSED)		SECONDARY 4 WIRE
	THREE PHASE TRANSFORMER OPEN DELTA (PROPOSED)		PRIMARY SINGLE PHASE
	THREE PHASE TRANSFORMER (PROPOSED)		PRIMARY TWO PHASE
	SINGLE PHASE TRANSFORMER (IN-SERVICE)		PRIMARY THREE PHASE
	THREE PHASE TRANSFORMER OPEN DELTA (IN-SERVICE)		
	THREE PHASE TRANSFORMER (IN-SERVICE)		
	ANCHOR GUY		
	ANCHOR GUY (PROPOSED)		
	ANCHOR GUY (REMOVAL)		
	SPAN GUY		
	PUSH BRACE ANCHOR		
	DUSK TO DAWN IDENTIFICATION		
	DUSK TO DAWN LIGHT		
	DUSK TO DAWN LIGHT REMOVAL		

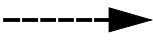
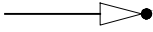
LEGEND













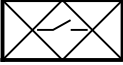
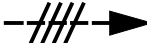

UNDERGROUND, SINGLE PHASE

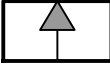
FRONT 	TRANSFORMER
FRONT 	J-1 CABINET
	SECONDARY PEDESTAL
	J-10 SURFACE MOUNT PEDESTAL
	CUSTOMER OWNED PEDESTAL
	PRIMARY CABLE
	SECONDARY CABLE
	SERVICE CABLE
	METER/SERVICE ENTRANCE
	SLEEVE OR SPARE CONDUIT
	CONDUIT DUCT STUB
	RISER QUADRANT

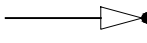



LEGEND

UNDERGROUND, THREE PHASE

FRONT 	TRANSFORMER		CAPACITOR
DOORS 	PME SWITCHGEAR (PROPOSED)		RISER QUADRANT
	VISTA SWITCHGEAR		CUSTOMER OWNED 4-WIRE SERVICE
	PME/PMH SWITCHGEAR (EXISTING)		COMPANY OWNED SECONDARY
FRONT 	J-2 CABINET		PRIMARY CABLE
	PULL BOX (MANHOLE)		METER/SERVICE ENTRANCE
	PULL BOX (LID TYPE)		SLEEVE OR SPARE CONDUIT
	SUB-SURFACE MOUNT PEDESTAL		CONDUIT DUCT STUB
			BUMPER POST

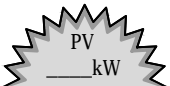
CUSTOMER TECHNOLOGIES (SECTION 700)

	BATTERY STORAGE
	PHOTOVOLTAIC (P.V. = SOLAR)
	HOT WATER (SOLAR)