

METERING INSTALLATIONS (GENERAL REQUIREMENTS)

1. METER SOCKETS

Meter sockets are supplied and installed by the customer or an electrical contractor. The meter socket shall be mounted so the socket jaws are in true horizontal and vertical planes and will support the meter without tilt in any direction.

Meter sockets shall comply with applicable **Company** Service Requirements, per SR-400 series and will be bonded per code.

Self-contained socket ratings:

Residential - All sockets shall have a maximum ampere rating not less than the ampacity of the main service switch. Maximum ampere rating of socket being 125% of continuous duty rating.

Commercial - All sockets shall have a continuous duty ampere rating not less than the ampacity of the main service switch.

2. METER SWITCH



For each and every meter, the customer or his contractor shall furnish and install a switch or other "approved disconnecting means" which shall control all of and only the energy registered by that meter. **Service will not be rendered until switch is installed.** The meter switch or other approved disconnecting device must have provisions for sealing it in the OFF position with a padlock seal. This may be accomplished by sealing the handle or breaker in the OFF position or by placing the handle or breaker in the OFF position and sealing the cover of the meter switch. In the latter case, each meter switch must be individually covered. The meter switch shall be bonded per code. **Meter switch panel designs that circumvent the locking mechanism of the door or switch, by means of removing the panel cover are not approved for installation.** This requirement applies to all switchboards, stand-alone, and switchgear installations.

3. METER SWITCH LOCATION WITH RESPECT TO METER

Every meter switch installed on a service of less than 600 volts shall be on the load side of the meter or metering equipment.

For residential service installations, the switch must be located outside in the immediate vicinity of the meter socket and accessible from the same working area as the meter socket.

For commercial installations, the switch may be located in an equipment room, **as described on page 7** or a meter room, **as described on page 8**. However, if the switch is installed outside, it must be located in the immediate vicinity of the meter socket, the same as for residential services.

		INITIATED BY	SC	REVISION NO.	11	SR-405 Pg. 1 of 10
		ESR COMM.	8-77	ESR COMM.	5-18	
				EFFECTIVE DATE	5-18	

METERING INSTALLATIONS (GENERAL REQUIREMENTS)

4. MAXIMUM AND MINIMUM SOCKET HEIGHTS

Maximum height to center of socket is six feet, three inches. Minimum height to center of socket is three feet, six inches. When a meter room is provided, the minimum height shall be three feet, except for multi-meter packs for which the minimum height is permitted to be two feet, six inches.

5. METER SOCKET AND METER SWITCH IDENTIFICATION



Residential, apartments and commercial service entrances shall have the complete street address of premises where new service is required plainly displayed. The address is to be placed on the front of the building and at each apartment or suite in plain view. For individual residential homes permanent addressing is required at the service entrance (see below for permanent identification requirements).



For apartment buildings and commercial buildings, TEP will not install service until all switches, meter sockets and interior distribution panels (first sub-panel) are permanently identified and the wiring from the multi-meter pack to the interior distribution panel is installed and terminated. Interior distribution panels (first sub-panel) will be labeled on the panel door and on the back or side of the interior of the panel.



Permanent identification for switches, meter sockets and interior distribution panels shall be made with metal tags with raised or etched letters and/or numbers. Identification labeling must maintain identity after being painted and shall be attached with rivets or screws.



When all of the meters in a multi-meter pack are scheduled to be set, **Company's** Meter Department will require the assistance of the customer, customer's agent or Service Provider prior to the setting of meters to verify that each meter socket is for the unit served through the socket.

6. METER ROOMS

Meters and metering equipment may be grouped in an accessible meter room. **Service Provider** must have access to meter rooms to facilitate reading and testing meters. (See Meter Room defined on Page 8)

7. SEALING OF TERMINATING PULL BOXES, RACEWAYS, ETC.

All terminating pull boxes, raceways, etc., installed on the line side of meter sockets shall have provisions for sealing with a padlock and/or wire seal.

		INITIATED BY	SC	REVISION NO.	9	SR-405 Pg. 2 of 10
		ESR COMM.	3-77	ESR COMM.	5-18	
				EFFECTIVE DATE	5-18	

METERING INSTALLATIONS (GENERAL REQUIREMENTS)

8. RING SEALS

TEP or Service Provider will seal all meter rings and devices mentioned in Requirement 7. The seal is a bond of mutual protection for TEP, Service Provider and the customer. It may not be broken by anyone except persons authorized to do so by TEP or Service Provider. If it becomes necessary for an electrician to access an enclosure which has been sealed by TEP, approval must be obtained from TEP as stated in the "Power Outage Requests," Page 1.25. If it becomes necessary for an electrician to access enclosure which has been sealed by a Service Provider, approval must be obtained by Service Provider. (Service Provider Seals are orange with company identifier).



9. METER AND/OR INSTRUMENT TRANSFORMER CABINET LOCATIONS

Meter equipment shall be installed on an exterior wall and will be accessible for reading and testing without entering the building. With approval of Design, Service Requirements & Service Delivery Dept. and Metering Department, meters and metering equipment may be grouped in an accessible meter room. (See Requirement 6)

10. PROHIBITED METER AND/OR INSTRUMENT TRANSFORMER CABINET LOCATIONS

In the interest of providing service to our customers and safe working conditions for our employees, certain locations for equipment installations shall be prohibited. Meters and associated equipment shall not be installed in the following locations **unless prior approval by the Design Build and Metering Services Departments has been given.**

- A. In any rest, bath, shower, or toilet room.
- B. Directly over any door, window, stairway, ramp, or steps.
- C. In any hazardous location.
- D. On any roof, attic, or place not in general use.
- E. In any basement.
- F. In any equipment room.
- G. Approval of locations D, E, and F will be based on the following facts:
 - 1) The meter and metering equipment are readily accessible for reading and testing, and access to them does not require procuring a key from the customer or permission to enter on each occasion. If, for any reason the customer (original or future) decides to stop **Service Provider** access to a metering location, the meter and metering equipment must be moved to a new approved location at the customer's expense.
 - 2) The location shall not be used to store valuable merchandise, equipment, etc.
 - 3) The location does not require **Company** employees to take hazardous or time consuming methods to gain access.
 - 4) The location is not a high security area with restricted access.

		INITIATED BY	SC	REVISION NO.	9	SR-405 Pg. 3 of 10
		ESR COMM.	8-77	ESR COMM.	5-18	
		ESR COMM.	8-77	EFFECTIVE DATE	5-18	



METERING INSTALLATIONS (GENERAL REQUIREMENTS)

10. PROHIBITED METER AND/OR INSTRUMENT TRANSFORMER CABINET LOCATIONS (cont'd)

- H. Any location where moisture, fumes, vibrations, or dust may interfere with the operation or materially damage the meter or metering equipment or may present a hazard to Company employees.
- I. In any substation or transformer vault, unless the meter is in an enclosure which is effectively screened from the high voltage compartment and contains no bare or exposed energized parts. Entry to vaults must be through normal doorways, not manholes, etc.
- J. In any enclosed show window or one having a raised platform or behind a sales counter.
- K. In or on any transformer cabinet, unless specifically designed and approved for that purpose.
- L. In any carport, breezeway or patio. Existing meters may remain in the aforementioned locations; however, the meter must be relocated if the service is upgraded or the location is enclosed. 
- M. In any school building hallway subject to student traffic.
- N. Any location subject to vehicular traffic which will present a hazard to the meter, meter readers, or service men, such as driveways, loading docks, etc.
- O. Any location where at least three feet of working clearance is not provided in front of all meter equipment.
- P. Any location that will require reading or servicing from within the fenced portion of a freeway.

 Q. In any area where a door swings and could result in damage to equipment or prevent safe operation.

- R. In any elevator shaft or hatchway.
- S. On any surface subject to excessive vibration.
- T. In any projection room.
- U. Directly over any stove or plumbing fixture.
- V. On any balcony or mezzanine floor, unless such balcony or mezzanine floor has a clear stairway of normal tread or rise and with utility approval.
- W. On the front exterior wall of a residence, unless mutually agreed to by the home builder, or customer and Service Provider. Other locations may be deemed prohibited by Design, Service Requirements & Service Delivery Dept. because of hazardous conditions or inaccessibility.
- X. Any floor above ground floor.
- Y. On or enclosed in any bedroom wall or bedroom closet wall.
- Z. On or recessed in the external surface of any building that is built within 3 feet of any property line or inline with any walk, alley, or driveway giving access to commercial or Industrial property. Other locations may be deemed prohibited by Design, Service Requirements & Service Delivery Dept. because of hazardous conditions or inaccessibility.

		INITIATED BY	SC	REVISION NO.	11	SR-405 Pg. 4 of 10
		ESR COMM.	8-77	ESR COMM.	8-18	
				EFFECTIVE DATE	8-18	

METERING INSTALLATIONS (GENERAL REQUIREMENTS)

11. WORKING SPACE

A level standing and working surface shall be provided and maintained in front of each metering installation. The service trench will be backfilled to final grade before calling for a metering inspection. The meter height is to be 3'-6" minimum and cannot exceed 6'-3". A clear and unobstructed working space shall be provided above the surface. The width of the working space shall be sufficient to permit ready access to the metering equipment and in no case less than 3 feet. The height of the working space shall be no less than 7 feet. The working space shall extend at least 3 feet in front of the surface on which the metering equipment is mounted and no less than 10 inches from the meter centerline to any obstruction such as walls, plants or trees. (See SR-405 pg. 10)

12. PROTECTION OF METERS AND METERING EQUIPMENT

In the interest of public safety and to prevent destruction of the customer's meter socket and TEP or Service Provider's meter, the customer when instructed by TEP shall provide and install a protective cabinet for enclosure of the socket and meter. This requirement shall be mandatory for installations located in parks or school yards. (See SR-420, Page 1, Meter Enclosure Cabinets.)

13. SEPARATION OF WIRING



Un-metered customer service wires and metered load wires are not to be run in the same conduit, raceway, or wiring gutter. Metered and un-metered wires shall be separated by suitable barriers. Metered wires from the customer's distribution section (branch circuits) shall not pass through sealable sections.

14. GROUNDING

The meter socket or enclosure shall be effectively grounded in compliance with applicable requirements of local governmental inspection codes, or National Electrical Code requirements in the absence of local codes.

15. GENERAL SERVICE CHANGEOUT OR UPGRADE

TEP will not splice underground service cable. If additional cable length is required due to meter base changeouts the customer will be required to lower the meter socket to obtain sufficient length or provide a new service conduit system (including new service riser) to TEP equipment. If the current conductor meets TEP's design needs and is damaged, the replacement of the conductor will be billable. Current transformer (CT's) used for transformer-rated metered services are no longer allowed in the secondary compartment of TEP three-phase pad-mount transformers. Upgrades or change-outs of this service type require removal of CT's from the transformer and installation in an approved customer-furnished CT can or switchgear section. Refer to SR-422 and SR-430 for additional information.

		INITIATED BY	SC	REVISION NO.	13	SR-405 Pg. 5 of 10
		ESR COMM.	8-77	ESR COMM.	5-18	
				EFFECTIVE DATE	5-18	

METERING INSTALLATIONS (GENERAL REQUIREMENTS)

16. COLOR CODING FOR 3 PHASE SERVICE CONDUCTORS

Wiring shall be color coded as follows:

PHASE	208/120V	240/120V	480/277V
A	BLACK	BLACK	BROWN
B	RED	ORANGE	ORANGE
C	BLUE	BLUE	YELLOW
NEUTRAL	WHITE	WHITE	GRAY
GROUND	GREEN	GREEN	GREEN

The service conductors shall be marked (taped) at the source and at the termination can or CT can. Start the marking tape 6 inches from the end of the conduit and for 4 inches minimal. Each Neutral will have a complete addressed DYMO aluminum label (1/2 inch) installed above this area facing out, so it can be read when accessing the cabinet compartment.

Note:

As a reminder when marking the power leg inside of a 240/120V or 480/240V safety socket box, place the conductor in the far right hand side of the safety socket box. Refer to SR-410 page 3 note 11, page 7 note 8, page 10 note 11.



17. ATTACHMENTS TO OR COVERING OF COMPANY METERS

Unless granted prior permission from the Service Provider, Customer shall not cover any Company meter, nor shall they attach anything to any Company meter.

METERING INSTALLATIONS

DEFINITIONS:

Terms frequently used in this book are herein defined:

ABOVE GROUND PEDESTAL (J-BOX): Houses secondary to service cable connections typically in residential subdivisions.

AIC: Amps Interrupting Current (or short circuit duty) The device rating to safely interrupt the flow of fault current.

ALL-IN-ONE SES (Service Entrance Section): Equipment manufactured as one unit.

AMERICAN WIRE GAUGE (AWG): The AWG assigns a number to a particular size of wire according to circular mill area to a maximum size of #0000.

CITY CLEARANCE: The approval of an electrical installation by the city or county having jurisdiction as an indication of compliance with its standards.

CONTINUOUS DUTY RATING: Operation at a substantially constant load for an indefinitely long time.

CONTINUOUS LOAD: A load where the maximum current is expected to continue for three hours or more.

CT's AND VT's (INSTRUMENT TRANSFORMERS): Transformers used to change electric current or voltage to values suitable for use in metering the consumption of electric energy.

These are owned, furnished and installed by the Company.

CT CAN (INSTRUMENT TRANSFORMER ENCLOSURE): In general, a metal cabinet owned and furnished by the customer, installed by the customer's electrical contractor, for use by the Company to enclose the Company's instrument transformers. Only CT cans approved by the Company and meeting Company specifications may be installed.

EMT: Electrical Metallic Tubing

EQUIPMENT ROOMS (Commercial and Industrial): An equipment room is an illuminated room provided by the customer for the customer's service entrance equipment. The room doesn't have a doorway opening to the outside of the building or into a public hallway; therefore, TEP / UES or Service Provider's meter or meters must be located on an outside wall in the immediate proximity of the equipment room. TEP / UES or Service Provider must have access to the equipment room during normal working hours.

EUSER OR EUSERC (Electric Utility Service Equipment Requirements Committee): The EUSER committee is an organization comprised of utility representatives from the Western Section of the United States which works to promote the standardization of electric service requirements and the design and engineering of metering and service equipment.

FAULT CURRENT: The short circuit amperage current produced during the unintentional contact of two parts of an electrical circuit that offers an alternate path for current to flow.



GENERAL PUBLIC AREA: An area where the general public has free access.

GROUNDING: Connected to earth or to some conducting body that serves in place of earth.

GROUNDING CONDUCTOR: A system or circuit conductor that is intentionally grounded.

GROUNDING CONDUCTOR: A conductor used to connect equipment or the grounded circuit of a wiring system to a grounding electrode or electrodes.

GROUNDING ELECTRODE: A ground electrode (rod) driven into earth to provide a base reference for voltage and a path to ground for fault current.

		INITIATED BY	GC	REVISION NO.	9	SR-405 Pg. 7 of 10
		ESR COMM.	8-77	ESR COMM.	5-18	
				EFFECTIVE DATE	5-18	

METERING INSTALLATIONS

DEFINITIONS

IMPAIRED CLEARANCE: The condition where a customer's structure(s), including, but not limited to, buildings, signs, towers, poles, fencing and swimming pools, is in a position or manner in which insufficient clearance, as specified by any applicable local code(s) and the National Electric Safety Code, as such codes now exist or as such codes may be amended, exists between the structure and the Company's existing transmission, substation, express feeder, street light or distribution line facilities, or any combination thereof.

INSTRUMENT TRANSFORMER COMPARTMENT OR CABINET: TEP requires a compartment in the service entrance equipment, or a separate cabinet furnished by the customer for the installation of the TEP or Service Provider's current transformers and, in some cases, voltage transformers. The compartment or cabinet is for TEP or Service Provider use only and shall be locked and/or sealed with TEP or Service Provider seals and locking devices. Contact Service Provider for their requirements. The compartment or cabinet shall not be used as a raceway for customer load conductors, other service conductors or any other equipment. The compartment or cabinet is to be used solely for TEP equipment.

INSTRUMENT TRANSFORMER METERING: Instrument transformers are used when either the current or voltage of a service is too great for a meter supplied by TEP or Service Provider to be installed as a self-contained meter. Current and voltage transformers have "secondary" windings in which the current or voltage is reduced by known ratios from that of the incoming service. These smaller voltages and/or currents are applied to an "instrument-rated" meter, the readings of which must be multiplied by a constant to obtain actual usage of the service. Instrument transformers are normally used on voltages above the nominal 480 Volt level, on 480 Volt services with 201 Amps or more and on 208Y/120 Volt or 120/240 Volt services with 201 Amps or more.

LOAD: The ratings of the power consuming apparatus which may be connected to TEP's installation or system under consideration.

MANUAL BYPASS: A mechanical jumper installed by a technician to keep the customer in service while a meter is removed for inspection or exchange.

METER ROOM (Commercial and Industrial): A meter room is an accessible, illuminated room provided by the customer for the location of the customer's electric service and metering equipment and for the installation of TEP or Service Provider meter or meters. The meter room may not be used for communications equipment. The meter room shall not be used for storage, and the working space is to be kept clear and unobstructed. Meter rooms shall be provided with a doorway opening to the outside of the building or into a public hallway. If there is a single door to the meter room and it must be locked, it must have a double hasp arrangement which will accommodate a TEP or Service Provider lock and the customer's lock. Meter rooms with two points of ingress/egress shall not be locked. Locking mechanism shall not be built into the door and labeled as such. A lock box or similar setup for a key to be used for the site shall not be acceptable. A double hasp arrangement shall be accepted.

METER ENCLOSURE: A Company-approved metal cabinet owned and furnished by the customer and installed by the customer's electrical contractor to enclose the Company's metering equipment. Meter enclosures will be sealed by the Company with Company's seal or lock.

POWER LEG (WILD LEG): The "C" (third) phase of a 4-wire delta secondary service shall be marked "orange". Orange colored vinyl electrical tape is an acceptable means for marking the conductor.

SECURELY ATTACHED: Attached to withstand anticipated loads not subject to loosening.



SELF-CONTAINED METERING: A self-contained meter is one which, when installed on a socket or mounting device, is capable of carrying the total current of the service supplied to the customer and of being directly connected to the line voltage of the service.

SERVICE ENERGIZATION: The connection of a service to a voltage source.

TYPE OF SERVICE: The characteristics of electric service described in terms of voltage, phase, frequency and number of wires.

WILD LEG: See "POWER LEG".

WITHSTAND CURRENT RATING: The maximum fault current rating that the device is rated to withstand.

		INITIATED BY	GC	REVISION NO.	3	SR-405 Pg. 8 of 10
		ESR COMM.	2-06	ESR COMM.	5-18	
				EFFECTIVE DATE	5-18	

USE: Requirements for Residential Socket Max. 200 amp Service

METERING INSTALLATION

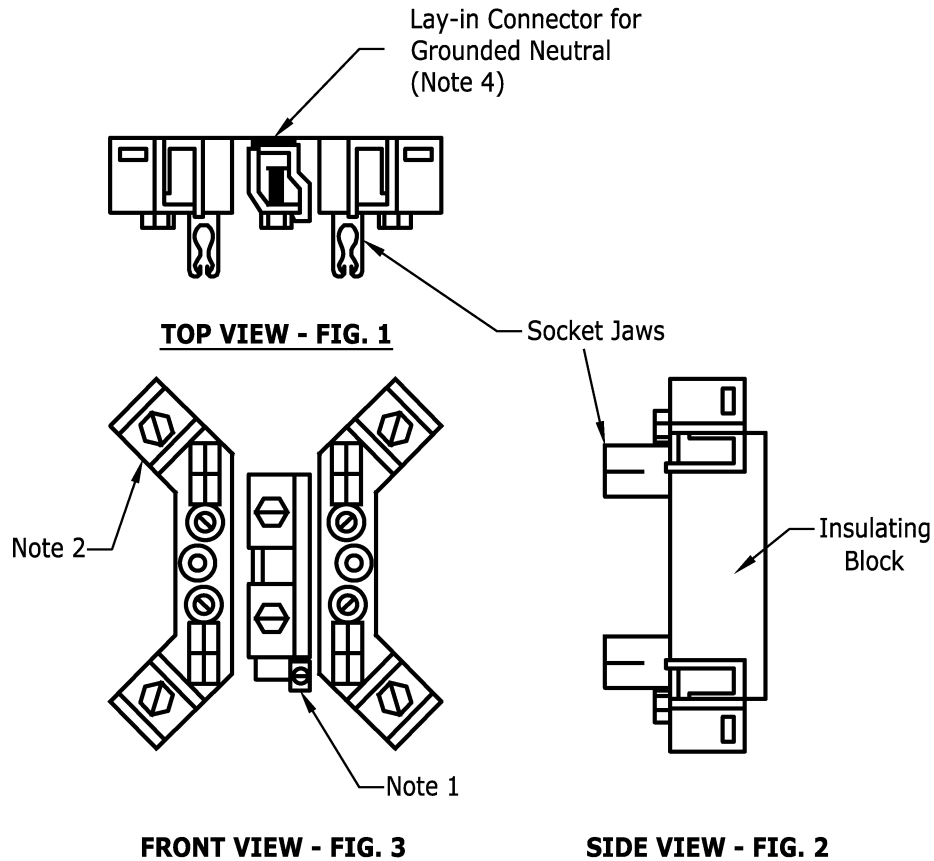

NOTES:

1. Neutral tap required for 5 jaw sockets only, 120/208V, 1Ø.
2. For underground service, line side connectors must be lay-in type approved for copper or aluminum conductor and shall be capable of accepting #6 to 1/0 AWG (100A) or 1/0 AWG to 250 kcmil (200A). For overhead service, they must accommodate customer's line and load conductors without removal of strands from ends of conductors.
3. Sockets must conform to ANSI C12.7 and be listed by a qualified electrical testing laboratory per NEC.
4. For underground service, the lay-in connector for grounded neutral must be suitable to terminate line and load neutral conductors in the socket and shall be bonded to enclosure. Line side neutral connector must be approved for copper and aluminum conductor and accept 1/0 through 3/0 AWG conductor.
5. Residential sockets shall have a maximum ampere rating not less than the rating of the main switch or service equipment. Maximum ampere rating of socket is 125% of continuous duty rating.
6. Only ring-type sockets will be approved.
7. Socket cover shall not be removable without removing meter. Latching device or mounting screws shall be accessible only after meter is removed. See SR-418 for meter pack requirements.

USE: Specifications for Meter Enclosures and Clear Working Space

METERING INSTALLATION

EUSERC DWG. No. G6 & G7

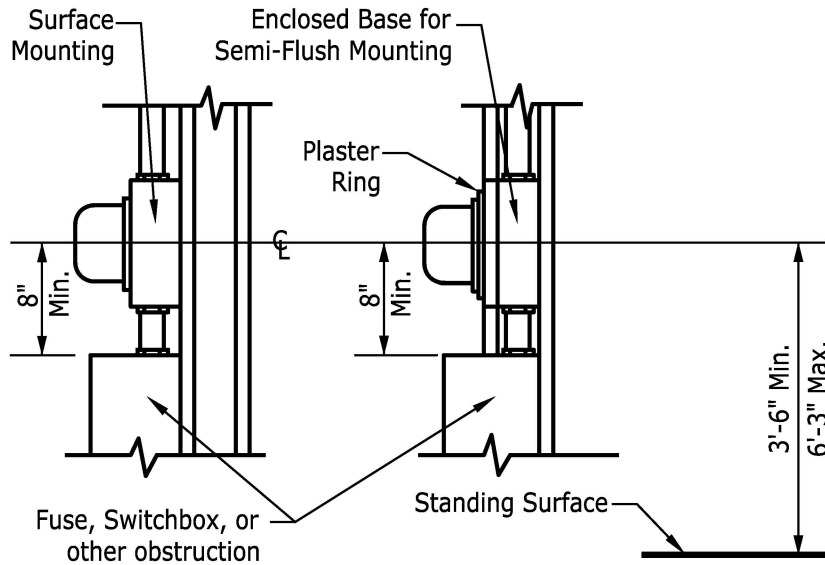

NON-ENCLOSED MOUNTING

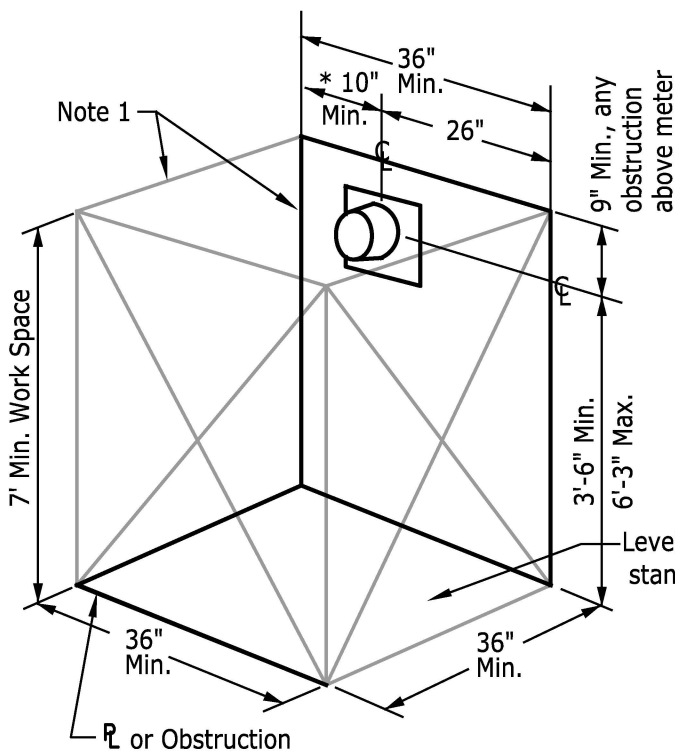

SEMI-FLUSH METER INSTALLATION

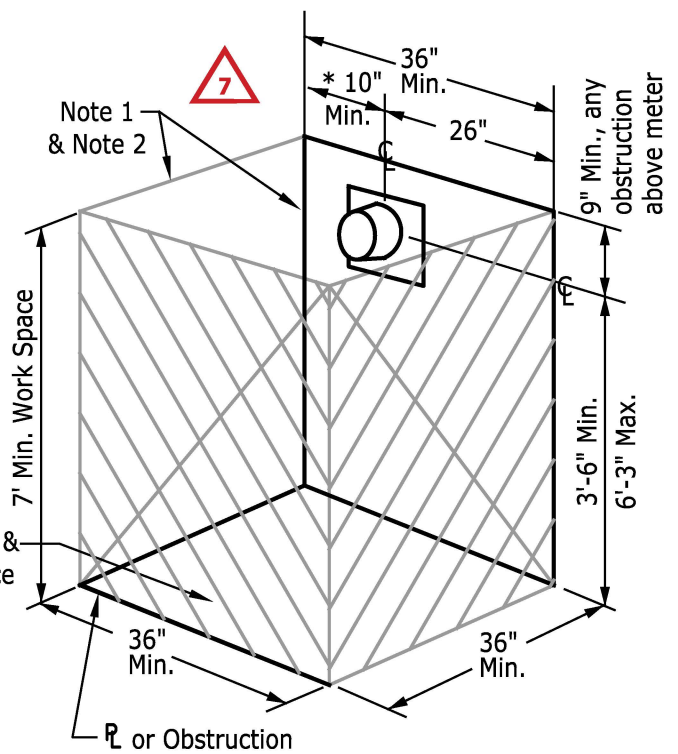

SCREEN WALL METER INSTALLATION

NOTES:



1. Nearest side wall or other obstruction.
2. One side of screen wall to remain open.
3. See note 11 of SR-405 pg. 5